

# Winged Test Rocket with Fully Autonomous Guidance and Control for Realizing Reusable Suborbital Vehicle

Koichi Yonemoto, Hiroshi Yamasaki, Masatomo Ichige, Yusuke Ura, Guna S. Gossamsetti, Takumi Ohki, Kento Shirakata, Ahsan R. Choudhuri, Shinji Ishimoto, Takashi Mugitani, Hiroya Asakawa, Hideaki Nanri

**Abstract**—This paper presents the strategic development plan of winged rockets WIRES (Winged REusable Sounding rocket) aiming at unmanned suborbital winged rocket for demonstrating future fully reusable space transportation technologies, such as aerodynamics, Navigation, Guidance and Control (NGC), composite structure, propulsion system, and cryogenic tanks etc., by universities in collaboration with government and industries, as well as the past and current flight test results.

**Keywords**—Autonomous guidance and control, reusable rocket, space transportation system, suborbital vehicle, winged rocket.

## I. INTRODUCTION

THE strategic road map of JAXA (Japan Aerospace Exploration Agency) for realizing reusable space transportation system is presented in Fig. 1 [1]. In parallel with the basic technology development for about 5 years, Japan will create new application and business units realized by the reusable space transportation system, which contribute social activities and demands by reducing financial burden of space development, promoting economic growth, solving resource problems of energy, food, and environment, and enhancing the security of the Asia Pacific Oceanic region etc. After the technology development by research and actual flight tests using small test vehicles are completed by 2020, the partially reusable space transportation such as small satellite launcher, reusable unmanned and manned shuttle will be realized in 15 years from 2020. The fully reusable space transportation system is expected to be operational after 2035.

Reference partially reusable satellite launchers planned by

Koichi Yonemoto is with Kyushu Institute of Technology, Sensui 1-1, Tobata, Kitakyushu 804-8550, Japan (corresponding author, phone/fax: +81-93-884-3179; e-mail: yonemoto@mech.kyutech.ac.jp).

Hiroshi Yamasaki, Masatomo Ichige, Yusuke Ura, Guna S. Gossamsetti, Takumi Ohki, and Kento Shirakata are with Kyushu Institute of Technology, Sensui 1-1, Tobata, Kitakyushu 804-8550, Japan (e-mail: n344156h@mail.kyutech.jp, o344105m@mail.kyutech.jp, o344107y@mail.kyutech.jp, o344155g@mail.kyutech.jp, p344112t@mail.kyutech.jp, p344124k@mail.kyutech.jp).

Ahsan R. Choudhuri is with the University of Texas at El Paso, Faculty of Engineering, Dept. of Mechanical Engineering, 500 W University Avenue, El Paso, TX 79968-0521, USA (e-mail: ahsan@utep.edu).

Shinji Ishimoto and Takashi Mugitani are with Japan Aerospace Exploration Agency, Shindai-ji Higashi-machi 7-44-1, Chofu, Tokyo 182-8522, Japan (e-mail: ishimoto.shinji@jaxa.jp, mugitani.takashi@jaxa.jp).

Hiroya Asakawa and Hideaki Nanri are with Japan Aerospace Exploration Agency, Sengen 2-1-1, Tsukuba 305-8505, Japan (e-mail: asakawa.hiroya@jaxa.jp, nanri.hideaki@jaxa.jp).

JAXA that will be operational from 2020 are shown in Fig. 2. The concept A is a vertical take-off and horizontal landing vehicle with the initial mass of 107 tons. It is propelled by rocket engines using hydrocarbon fuel to accelerate up to the Mach number 10 and launch an expendable upper stage from the altitude of 70km. This vehicle flies forward and land on a runway located in the down-range. The expendable stage has the payload capability of more than 500kg to the low earth orbit of 500km altitude. The concept B has the same mission concept and stores the same expendable upper stage, but can fly back to the launch site using additional air breathing engines. The concept C is a vertical take-off and landing vehicle using rocket engines.

WIRES-X (Winged REusable Sounding rocket) shown in Fig. 3 is a conceptual suborbital winged rocket under study by Kyutech. It employs the aerodynamic shape of HIMES (Highly Maneuverable Experimental Space vehicle) studied by Institute of Space and Astronautical Science (ISAS) of JAXA in 1980s [2]. WIREX-X will reach the altitude more than 100km, and demonstrate all the key research issues such as aerodynamics, navigation, guidance and control (NGC), composite structure including health monitoring system, cryogenic composite tanks and advanced rocket engine of hydrocarbon fuel etc. by 2020 (Fig. 4). WIRES-X has the total length of 9.3m, initial mass of 4.6 tons and payload capability of 100kg. It will be propelled by a single LOX-Methane engine of 100kN thrust newly developed by IHI.

In 2008, Kyutech first developed a very small winged rocket called WIRES#011 and conducted experimental flight for five times to demonstrate the attitude control performance of ascent phase [3]. In 2010, a conventional rocket called WIRES#012 was developed to demonstrate the new flight termination and recovery system using two-stage parachute and airbags for the safety operation. Kyutech completed its experimental flights in 2011 successfully. Since 2012, Kyutech is developing a larger winged rocket WIRES#014 for demonstrating on-board real-time guidance and attitude control system. WIRES#014 is the first development collaboration with JAXA, and the flight tests are underway. Kyutech and University of Texas at El Paso (UTEP) have already started to design a relative larger winged rocket WIRES#015 as a pre-demonstrator of suborbital vehicle in collaboration with JAXA, IHI, IHI Aerospace, PD Aerospace and other domestic companies.

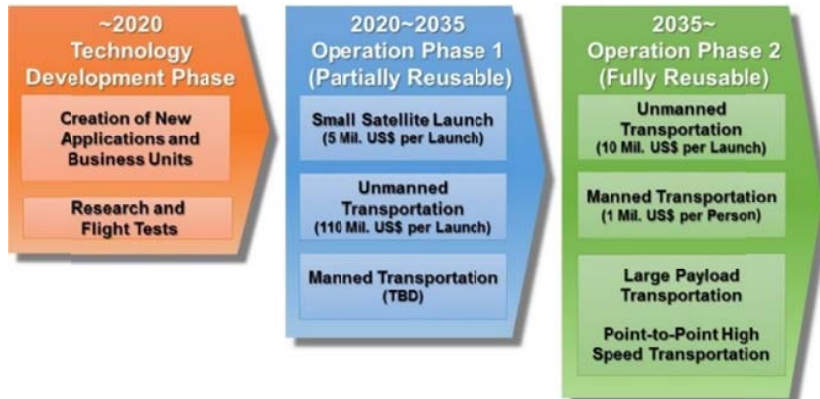

Fig. 1 Road map of reusable space transportation system

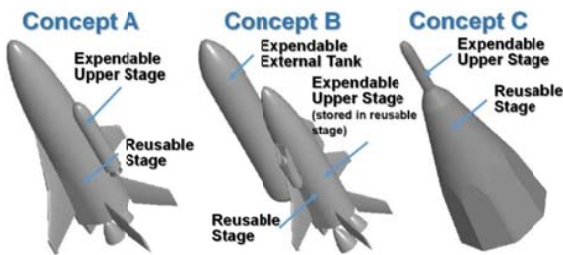

Fig. 2 Partially reusable small satellite launcher



Fig. 3 Suborbital winged rocket WIRES-X

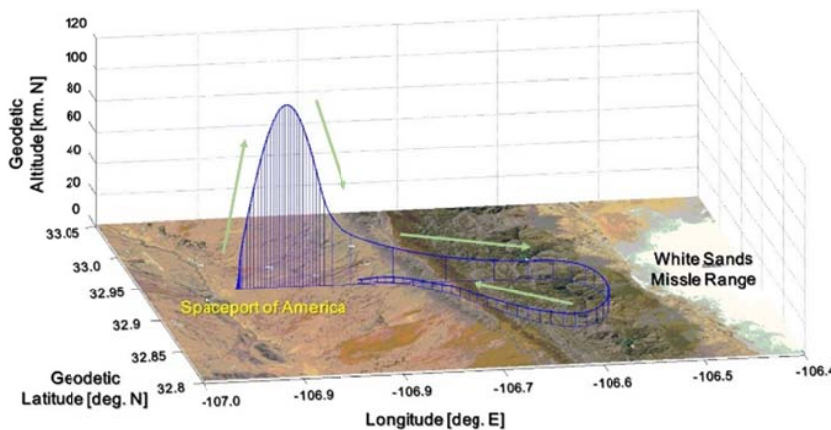

Fig. 4 Flight profile of WIRES-X

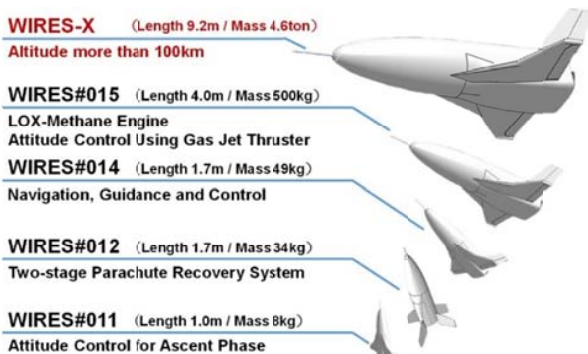

Fig. 5 Development scenario of winged rockets WIRES

This paper gives flight test results of small winged rocket WIRES to date and the future development plan aiming at the suborbital technology demonstrator WIRES-X by universities in collaboration with government and industries as shown in Fig. 5 [4].

## II. FLIGHT TESTS TO DATE

### A. WIRES#011

A small winged rocket WIRES#011 developed in 2008 by Kyutech students has a semi-monocoque structure using GFRP (Glass-Fiber-Reinforce-Plastic) skins and frames/stringers made of wood (Figs. 6 and 7). The total length is 1m, and the initial mass is 8kg. It had a solid rocket motor (AeroTech

J125-10W of RCS Rocket Motor Components Inc.), and could reach the altitude of 0.5km. WIRES#011 was launched five times to evaluate its attitude control of ascent phase based on the  $H_\infty$  theory (Fig. 8) [5].

**B. WIRES#012**

WIRES#012 (Fig. 9) is a conventional rocket to establish all composite body structure made of CFRP (Carbon-Fiber-Reinforce Plastic) and to demonstrate a new flight termination and recovery system using two-stage parachute and airbags for the safety operation (Fig. 10). The total length is 1.7m and initial mass is 34.3 kg. It is capable to reach the altitude of 1.1km using commercial hybrid rocket (HyperTEK M1000 of Cesaroni Technology Inc.).



Fig. 7 Assembly and check out of WIRES#011

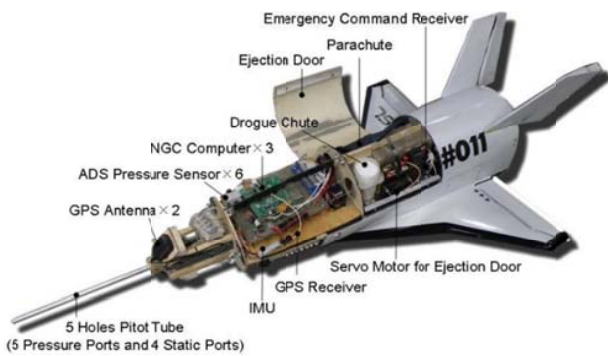

Fig. 6 Subsystem layout of WIRES#011

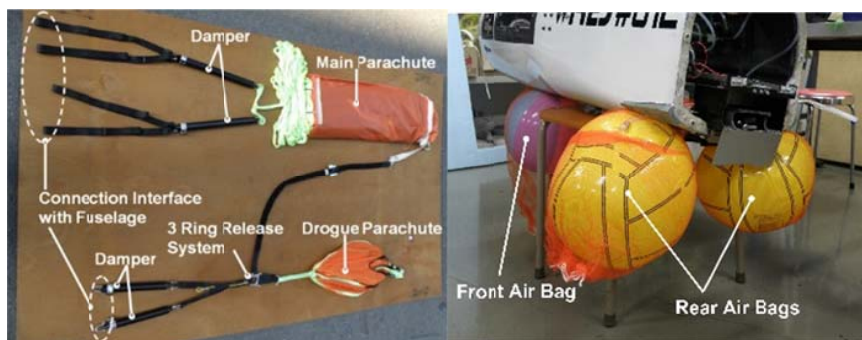

Fig. 8 Third flight test of WIRES#011

WIRES#012 was launched three times in total, and the last flight was conducted in 2011. The firing of rocket engine was operated by the remote control system, and the flight data was transmitted by telemetry down from WIRES#012 to the flight monitoring system at the control center 800m away from the rocket launcher (Fig. 11). The flight altitude was about 760m, and the maximum velocity was about 130m/s. It was recovered completely without any major damage as shown in Fig. 12 [6], [7].



Fig. 9 Conventional test rocket WIRES#012



(tow stage parachute)

(airbag)

Fig. 10 Recovery system of WIRES#012



Fig. 11 Remote operation at flight control center



Fig. 12 Third flight test of WIRES#012

### C. WIRES#014

#### 1. Major Dimensions

WIRES#014 is a winged rocket that performs fully autonomous flight using integrated navigation and real-time on-board guidance associated with an advanced control system (Fig. 13). The major dimensions are shown in Table I.



Fig. 13 Winged test rocket WIRES#014

#### 2. Structure

WIRES#014 has full composite semi-monocoque structure of skin, frame, and stringer made of lightweight and highly rigid CFRP, which were molded and bonded by students in the university laboratory as shown in Fig. 14. The frame and stringer have sandwich structure that consists of CFRP surface panel and foam core (Divinycell). The nose cone is made of GFRP to prevent radio shielding. The two elevons and two rudders have also the sandwich structure of CFRP surface panel and foam core.

TABLE I  
MAJOR DIMENSIONS OF WIRES#014

Initial Mass	[kg]	49.3
Total Length	[m]	1.7
Total Length	[m]	1.7
Body Diameter	[m]	0.33
Wing Span	[m]	1.1



Fig. 14 Full composite semi-monocoque structure of WIRES#014

#### 3. Avionics

The on-board avionics of WIRES#014 has five micro-computers such as control, sensing, GPS/telemetry, logging and navigation, which are connected by CAN (Controller Area Network) Bus (Fig. 15).

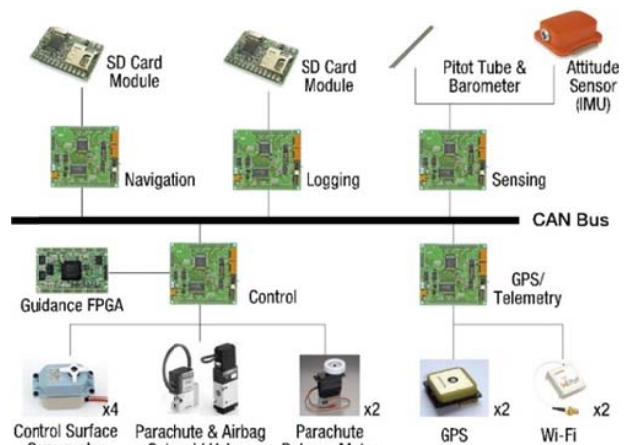

Fig. 15 On-board avionics of WIRES#014

The control micro-computer operates servo motors (PS050 of Tonegawa-Seiko Co., Ltd.) of aerodynamic surfaces (elevons and rudders), solenoid valves of parachute and air bags, and release motors of parachute raiser. The Field Programmable Gate Array (FPGA: Spartan-6 XC6SLX150 of Xilinx Inc.) connected with the control micro-computer calculates optimal and reference trajectory for guidance. The sensing micro-computer processes the signals from the IMU (Inertial Measurement Unit: MTi of Xsens B.V.) to measure the attitude and acceleration, and a 5-hole pitot tube developed by Kyutech to measure air speed, angle of attack, sideslip angle and pressure altitude. The GPS (Global Positioning System)/telemetry micro-computer processes the signals from GPSs and put the signals to Wi-Fi transmitters. The logging micro-computer records all the flight data. The navigation

micro-computer calculates the attitude and trajectory parameters based on the signals of GPS, ADS (Air Data Sensing System) and IMU. Three cameras are installed on-board to record the flight view.

#### 4. Propulsion System

WIRES#014 employs hybrid rocket engine called CAMUI (Cascaded MULTistage Impinging-jet) supplied by Uematsu Electric Co., Ltd. (Fig. 16 and Table II) [8]. CAMUI has polyethylene grain as the fuel, in which the combustion gas flow is configured to yield higher specific impulse than the conventional hybrid engine. The liquid oxygen is fed to the combustion chamber using high pressure helium gas.

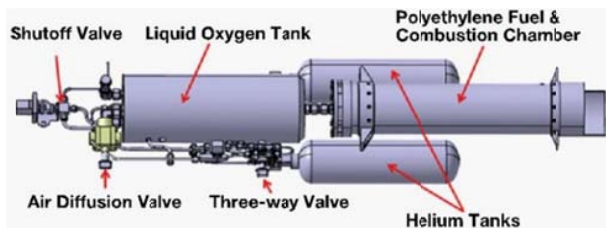

Fig. 16 CAMUI hybrid rocket engine

TABLE II  
SPECIFICATIONS OF CAMUI

Total Impulse	[Ns]	13220
Specific Impulse	[s]	240
Maximum Thrust	[N]	3000
Average Thrust	[N]	2550
Combustion Time	[s]	3.8
Total Mass	[kg]	20.5

#### 5. Ground Combustion Test

The ground combustion test of WIRES#014 aims at acquiring actual thrust data of CAMUI and verifying the tolerance of on-board avionics and emergency system under the mechanical shock and oscillation due to engine combustion.

The ground combustion tests were conducted three times. The first and second tests were failed due to the mistake of engine valve operation, on-board software bug and malfunction caused by electromagnetic noise. Searching the causes of failures, the third ground combustion test was conducted successfully in 2012 (Fig. 17). The thrust profile of CAMUI is compared with that of engine alone combustion test as shown in Fig. 18.

#### 6. Hardware-in-the-loop Simulation Test

A hardware-in-the-loop simulator for WIRES#014 was developed to verify the function of on-board avionics and adjust the parameters of NGC software (Fig. 19) [9]. The motion simulation computer senses the deflection angles of elevons and rudders to solve the equations of motion, and inputs pseudo GPS and ADS signals to the on-board avionics simultaneously. The tri-axis motion table moves the IMU according to the attitude calculated by the motion simulation computer to close the feedback loop between the on-board avionics and the motion simulation computer.



Fig. 17 Third ground combustion test of WIRES#014

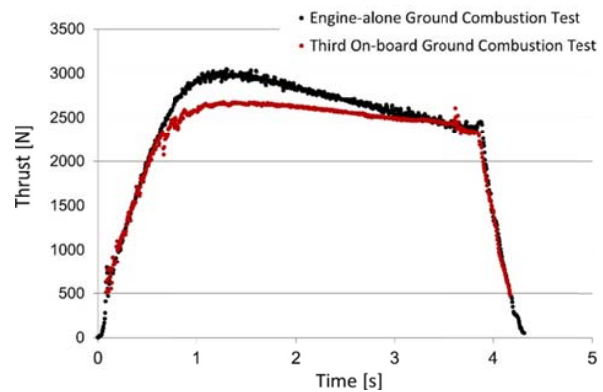

Fig. 18 Thrust profile of CAMUI

#### 1. Flight Test

The flight test of WIRES#014 was conducted in 2013 at the Hiraodai Countryside Park of Kitakyushu. The ignition of CAMUI was successful, but the attitude control failed short after leaving the launcher. WIRES#014 could neither reach the altitude nor perform gliding flight as planned to get into a ballistic flight and finally crashed on ground (Fig. 20). The flight data stored on-board and transmitted by telemetry (Fig. 21) was analyzed to detect the cause of failure. The pressure altitude and true air speed measured by ADS are compared with those obtained by GPS. Since the behavior of ADS was found not normal, it was concluded that one of causes of the flight failure was the malfunction of ADS concerning the pressure piping or pressure sensors themselves. Based on the post flight analysis, the error in control law was also detected. Kyutech is manufacturing new WIRES#014 by improving the technical problems of the first flight. The next flight is planned in November 2015.



(a) Hardware system

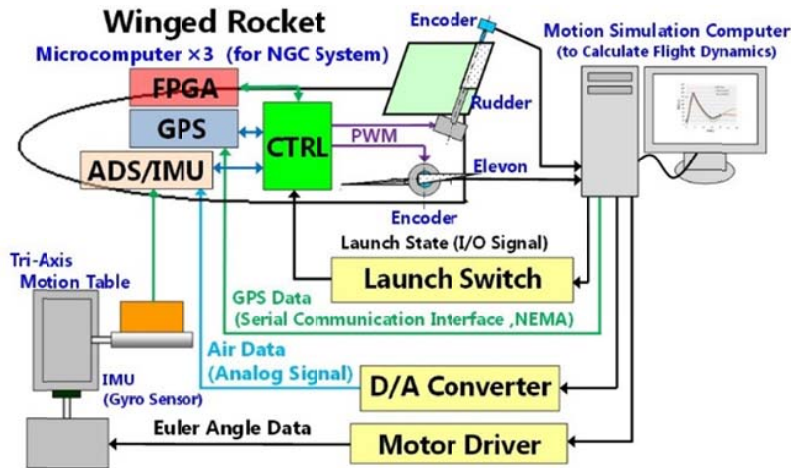

(b) System block diagram

Fig. 19 Hardware-in-the-loop simulator

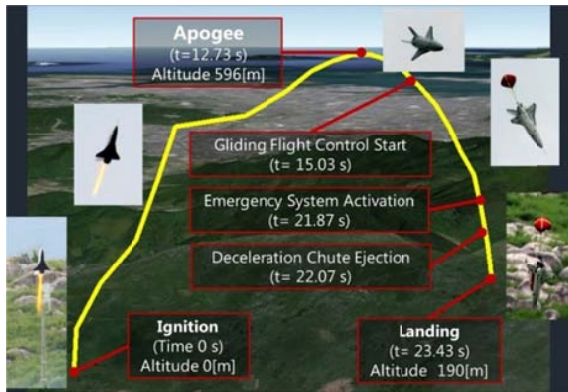

Fig. 20 Flight profile of WIRES#014

### III. DEVELOPMENT OF WIRES#015

#### A. Overview

Kyutech and UTEP have started to design and develop WIRES#015 in collaboration with JAXA, IHI, IHI Aerospace, PD Aerospace and other domestic companies [10]. The main mission of WIRES#015 is to evaluate the following advanced navigation, guidance, and control technologies:

- (1) Estimation of Pseudo Aerodynamic Posture using INS-GPS-ADS Hybrid Navigation
- (2) Fault Tolerant Flush Air Data Sensing (FADS) System
- (3) Real Time Optimal Trajectory Generation using Dynamically Distributed Genetic Algorithm (Dyn DGA)
- (4) Digital Model Reference Adaptive Control System

The additional but important objectives of the flight test are as following:

- (a) Demonstration of LOX-Methane Propulsion Technology
- (b) Reentry Attitude Control System by Gas Jet Thrusters
- (c) Recovery by Two-stage Parachute System and Air Bags

The total length of the vehicle is 4 m and with launch mass of 500 kg (Fig. 22, Table III). The rocket reaches the altitude of 6 km with the 10kN thrust and 30 seconds combustion time of

LOX-methane engine.

#### B. Structure and Subsystem Arrangement

WIRES#015 has full composite semi-monocoque structure of CFRP skin with foam core sandwich as employed by WIRES#014. The nose cone is made of GFRP to prevent radio shielding. The fuselage is divided into the front and rear body at the location as shown in Fig. 23. The subsystem arrangement is shown in Fig. 24.

The GHe (Gaseous Helium), Methane and LOX tanks (Fig. 25) are made of composite fiber wrapped aluminum liner vessels, which has the volume of 95, 103 and 115 liters respectively as shown in Fig. 25. The mean operating pressure of methane and LOX is 2.6 MPa, while the high pressure GHe is maintained at 25 MPa.

#### C. Avionics

The avionics of WIRES#015 has five microcomputers such as navigation, guidance, control, communications and engine, which are connected by ARINC 429 bus system as commercial aircrafts do (Fig. 26). In addition to the main avionics, there are dual emergency microcomputers by employing fault tolerant design.

ARINC 429 is a time triggered system used to transmit data at a predetermined time interval between the microcomputers. The data levels will be prioritized based on the requirement. Each microcomputer has its own data loggers to reduce the load on the bus system. During flight, when a system malfunction occurs and the control/engine microcomputer of avionics doesn't react, an emergency sequence is operated from the ground control center. The emergency microcomputer on the vehicle uses the relay, shifts the command priority from main microcomputer to the emergency microcomputer and emergency sequence is operated. The emergency system is a double fault tolerant system as the microcomputers and the receivers are duplicated for redundancy. The EM model of the bus system has been fabricated, and is under testing (Fig. 27).

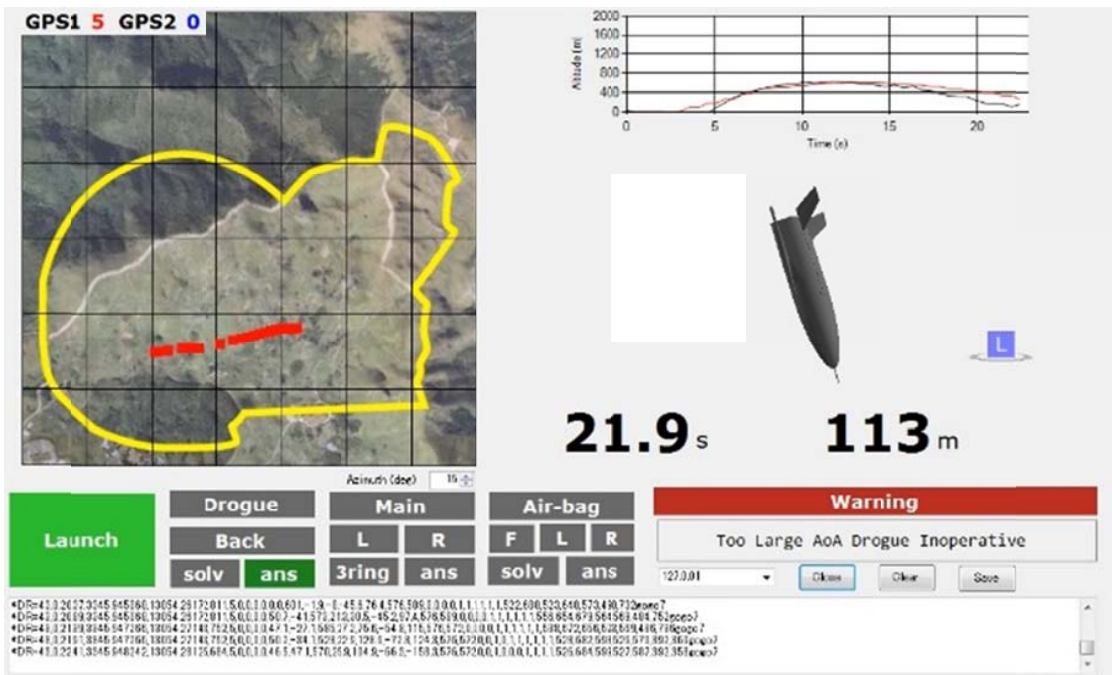

Fig. 21 Flight monitoring of WIREs#014 by telemetry

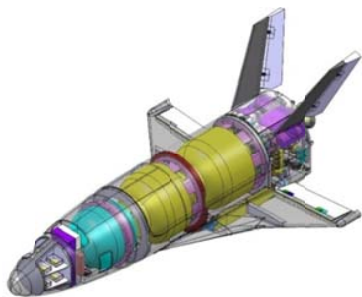

Fig. 22 Winged test rocket WIREs#015

*D. Propulsion System*

The LOX-methane engine with the thrust of 10kN for WIREs#015 is developed by IHI Aerospace under the contract of JAXA as shown in Fig. 28. It has a gimbal system for counter

reacting any thrust misalignment. The engine will be utilized more than 20 times (10 for ground combustion tests and 10 for actual flight tests). The high pressure GHe is utilized for driving the oxidizer and fuel to the engine. The block diagram of propulsion system is shown in Fig. 29.

TABLE III  
MAJOR DIMENSIONS AND SPECIFICATIONS OF WIREs#015

Initial Mass	[kg]	500
Total Length	[m]	4
Body Diameter	[m]	0.76
Engine Thrust	[kN]	10
Specific Impulse	[s]	230
Apogee	[km]	>6

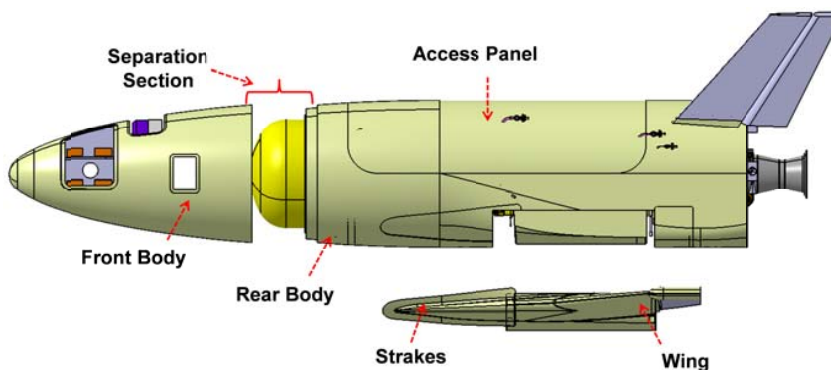

Fig. 23 Composite semi-monocoque structure

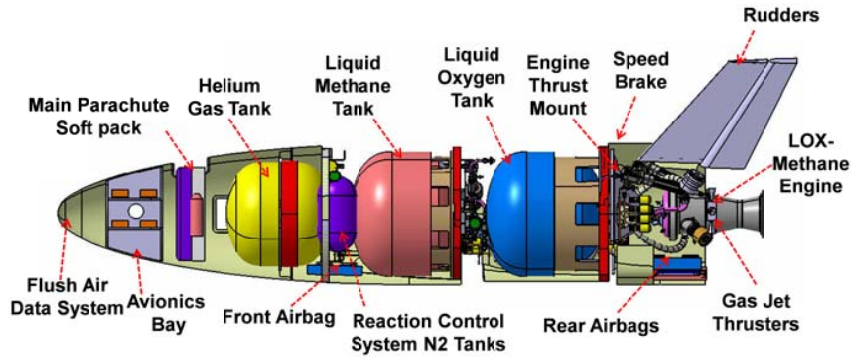

Fig. 24 Subsystem arrangement

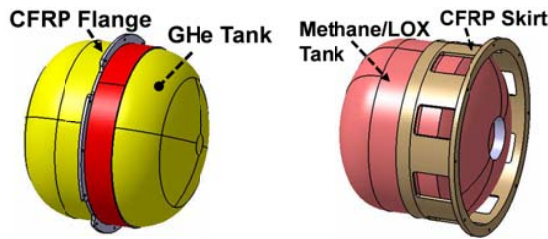

Fig. 25 GHe, methane and LOX tanks

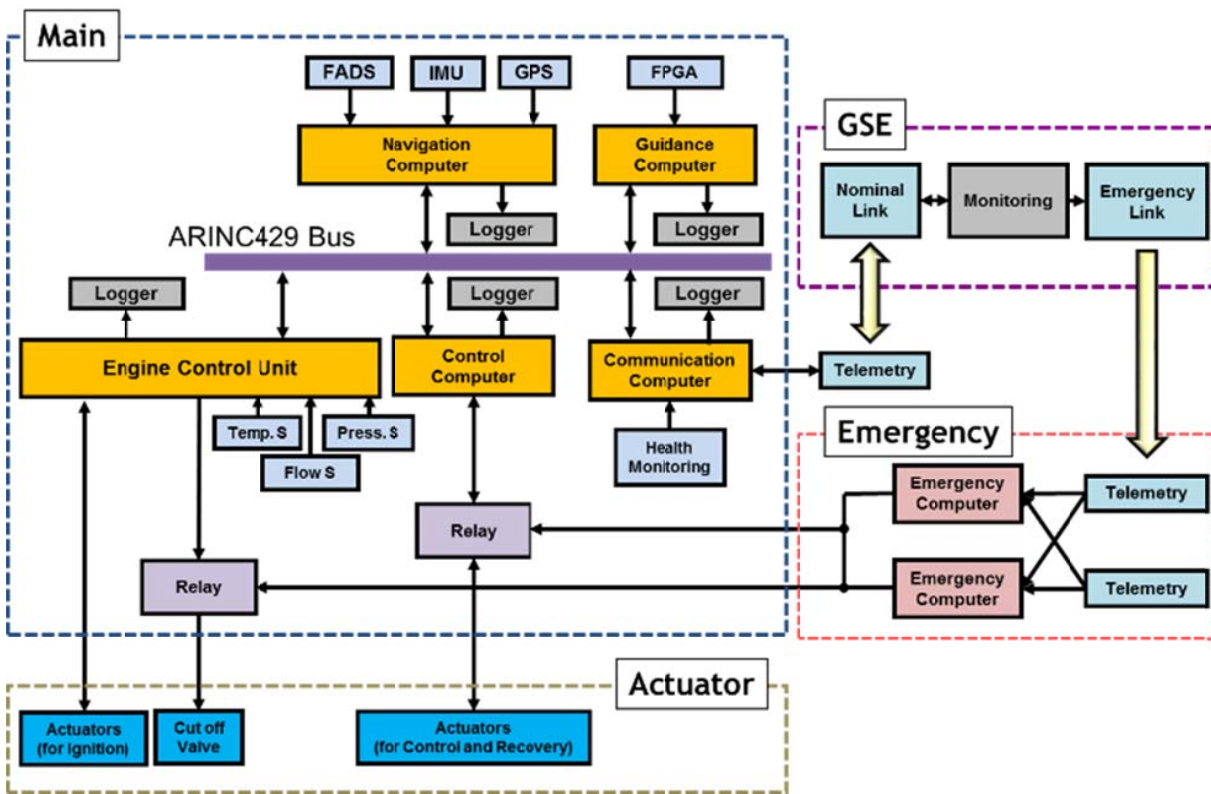

Fig. 26 Block diagram of onboard avionics



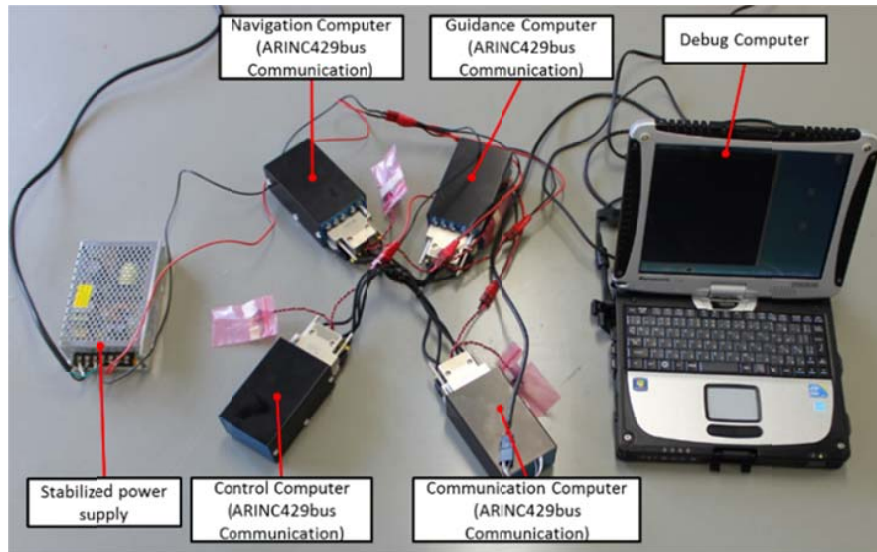
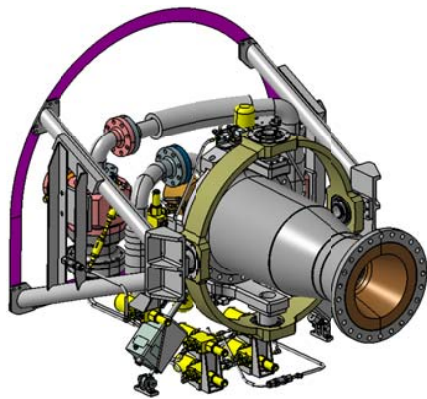
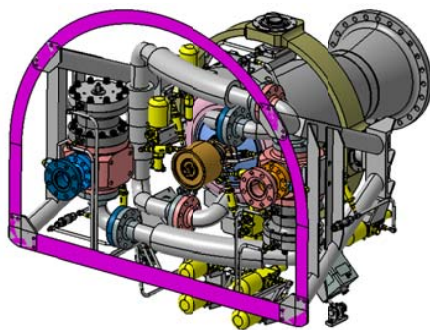

Fig. 27 EM model of Arinc429 bus system



(a) Viewed from vehicle's rear



(b) Viewed from vehicle's nose

Fig. 28 LOX-methane engine with gimbal system

#### D. Reaction Control System

Reaction control thruster (also called gas jet thrusters) are utilized for the attitude control of WIRES#015 at the apogee of trajectory, where dynamic pressure become small and aerodynamic control surfaces are no more effective. The

reaction control system (RCS) consists of 6 thrusters (3 on either side of the vehicle), 6 on/off valves and 1 pressure regulator, which supply the residual helium gas from the GH2 tank. Using various combinations of thrusters, the pitch, yaw and roll motion of the vehicle can be controlled. The RCS specification, the location of RCS thrusters and the block diagram of GHe supply system are shown in Table IV, Figs. 30 and 31 respectively.

#### E. Recovery System

At the terminal flight phase of WIRES#015, the deceleration chute is ejected and the vehicle's velocity is reduced for ejecting the main parachute. Once the main parachute is ejected, the airbags are deployed. The three airbags mounted on the vehicle utilize the commercial automobile airbags system without the exception of vent ports. Instead, relief valves will be used, which will open after landing to reduce the volume. An outline of the recovery system is shown in Fig. 32. The airbags are being developed in collaboration with an automobile company and will be equipped with 3 gas canisters each, which are deployed sequentially to maintain the shape as shown in Fig. 33.

#### F. Ground Support System

The preliminary concept of the launcher system is shown in Fig. 34. The launcher has a total length of 15 m with launch angle ranging from -2 deg. to +92 deg. The launch rail is supported by two guide rails for sway bracing. The design of the ground control center (Fig. 35) is under progress. All system confirmations, fuel filling and the ignition commands will be directed from the control center through ground telemetry. Web-cameras will monitor the launch site in real time.

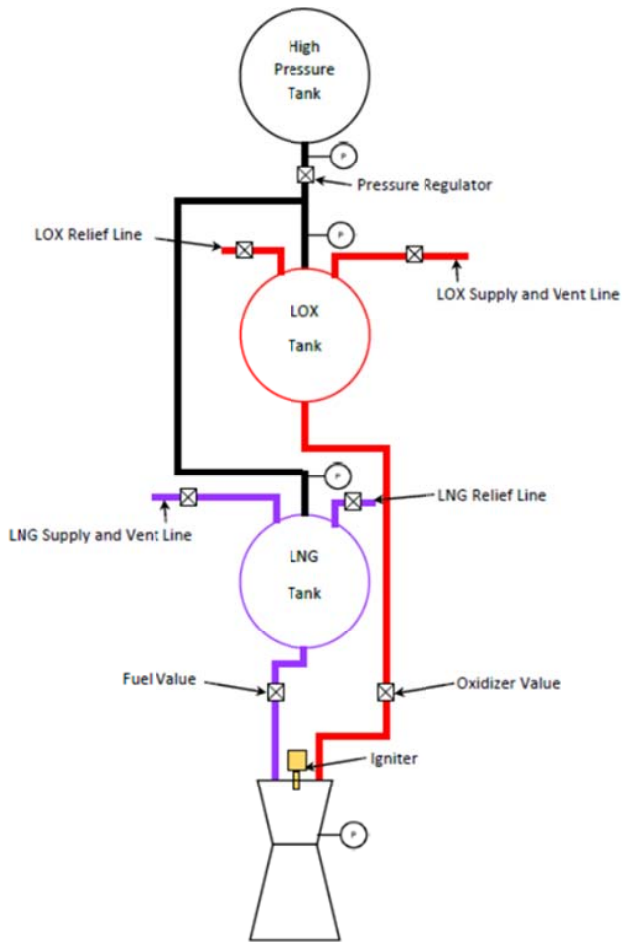

Fig. 29 Block diagram of propulsion system

TABLE IV  
Specifications of RCS

No. of Thruster	[-]	6
Thrust at Sea Level	[N]	22
Full Duty Time	[s]	30
Gas Type	[-]	He
Tank Pressure	[MPa]	11.5
Thruster Pressure	[MPa]	2.5

*G.Hardware-in-the-loop Simulator*

A new hardware-in-the-loop simulator (HILS) has been developed for the development of WIRES#015. The HILS consists of a motion simulation computer, 2 motion tables for the inertial navigation system (INS) and aerodynamic pressure. The motion simulation computer calculates the dynamics of the rocket, controls the motion tables, and displays their states in real time. The angle of attack and angle of side slip are very important parameters for the attitude control law, for this reason an aerodynamic pressure motion table simulates the aerodynamic attitude; angle of attack and angle of side slip. Fig. 36 shows the system diagram of HILS and the motion tables with INS and aerodynamic pressure.

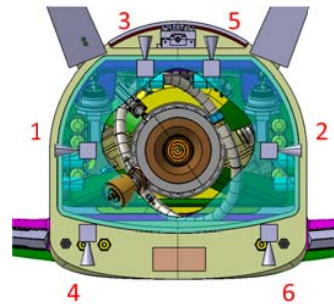

No.1, 2: Yaw Thrusters  
No. 3, 4, 5, 6: Roll and Pitch Thrusters

Fig. 30 Location of RCS thrusters

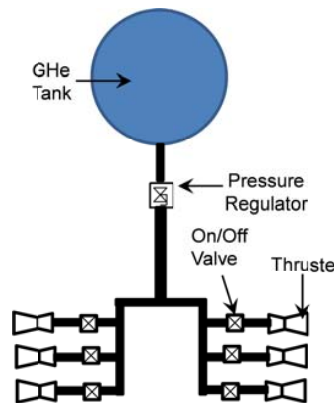

Fig. 31 Block diagram of GHe supply system

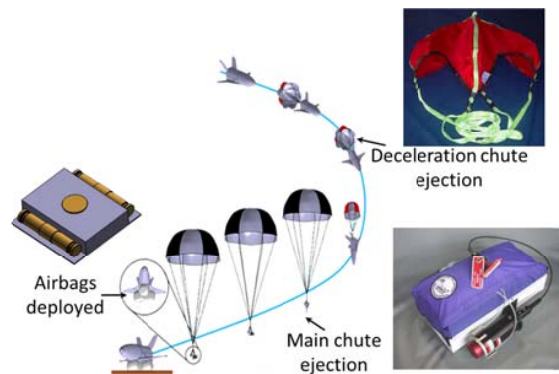

Fig. 32 Recovery systems

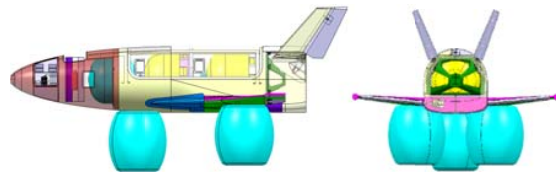

Fig. 33 Airbag system

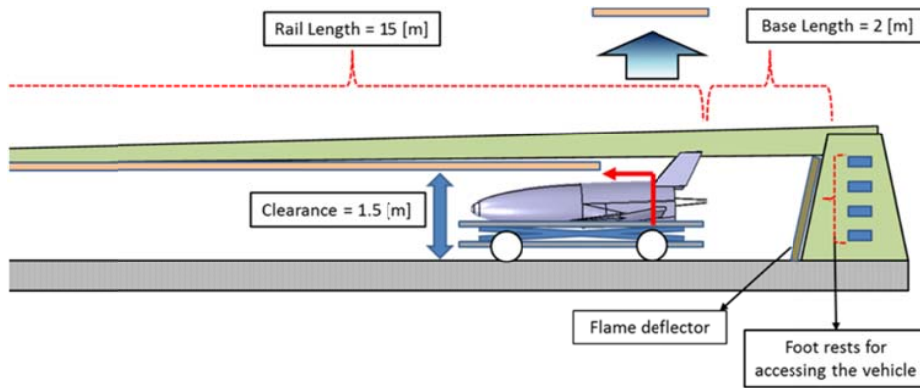

Fig. 34 Launcher system

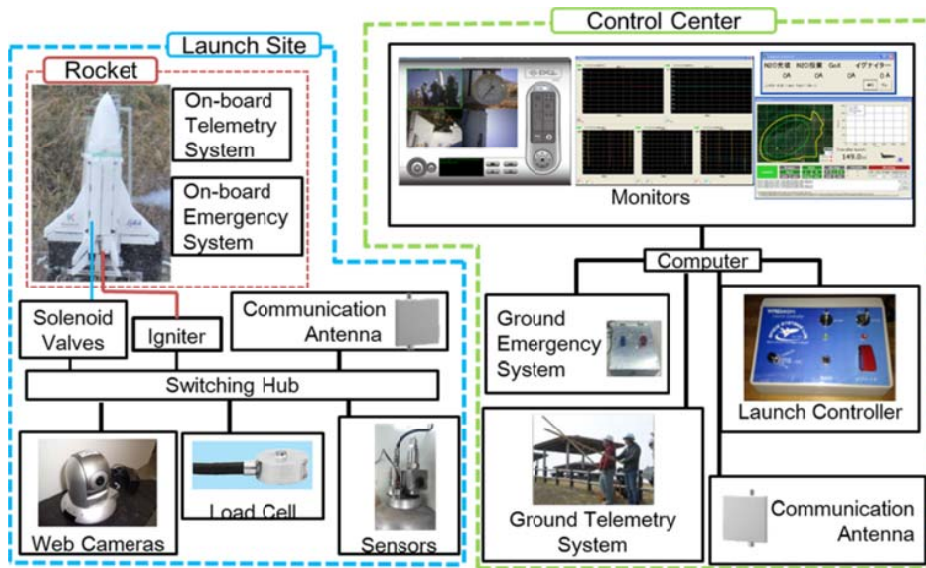
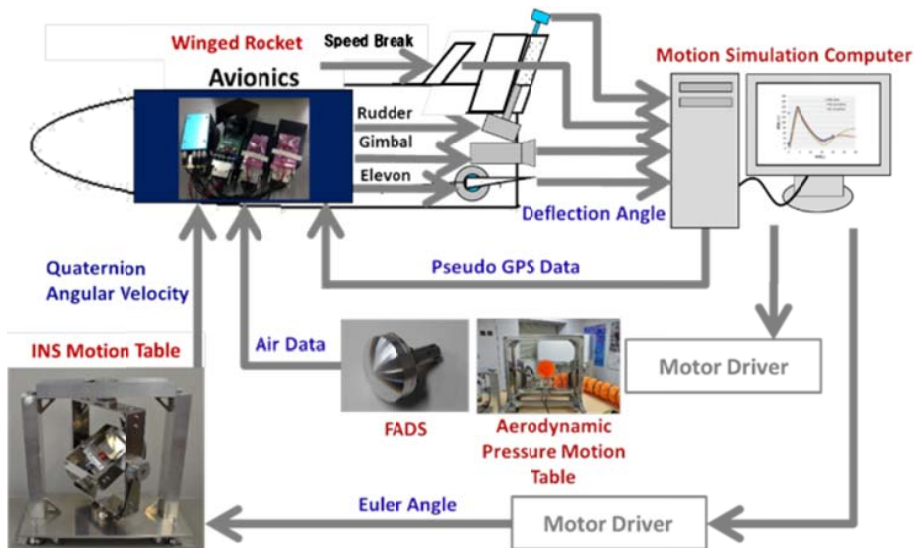
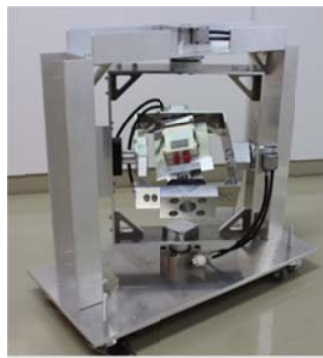

Fig. 35 Ground support system and control center



(a) System block diagram



(b) INS motion table

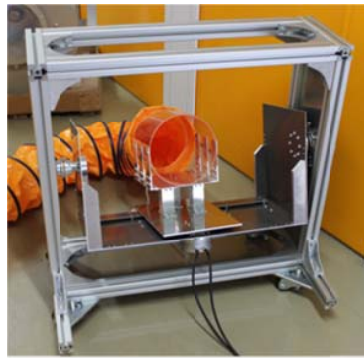

(c) Aerodynamic pressure motion table

Fig. 36 Hardware-in-the-loop simulator

#### IV. CONCLUSION

The authors have completed redesign and reproduction of small scaled winged test rocket WIRES#014. After the pre-flight review in October by JAXA and other companies, the 2<sup>nd</sup> flight test of WIRES#014 will be conducted in November 2015.

In parallel with the preparation of the flight test of WIRES#014, the authors have started to design of larger winged test rocket WIRES#015 for demonstrating advanced NGC and other important research issues, such as LOX-methane engine etc., to realize fully reusable suborbital vehicle. This winged test rocket development project by the industry-government-academia collaboration is a very unique activity in not only Japan, but also internationally, which is expected to contribute to the progress of fully reusable space transportation research.

#### REFERENCES

- [1] Ishimoto, S., "Study Status on Reference Models of Reusable Space Transportation System," the 3rd Workshop of Reusable Space Transportation System, Tokyo, Japan (in Japanese) (2014).
- [2] Inatani, Y., Kawaguchi, J. and Yonemoto, K., "Status of 'HIMES' Reentry Flight Test Project," Proceedings of AIAA 2nd International Aerospace Planes Conference, AIAA 90-5230 (1990).
- [3] Wakita, M., Yonemoto, K., Akiyama, T., Aso, S., Kohsetsu, Y. and Nagata, H., "Development Project of Winged Experimental Rocket Led by University Consortium," Transactions of the Japan Society for Aeronautical and Space Sciences, Space Technology Japan, Vol. 7, No. ists26, pp.13-18 (2009).
- [4] Yonemoto, K., Matsumoto, T., Choudhuri, A., R., Ishimoto, S., Mugitani, T., Makino, T., Kimoto, K., Ogawa, S., and Irino, Y., "Development of Small Winged Rockets for Suborbital Technology Demonstration by Universities in Collaboration with Government and Industries," 65th International Astronautical Congress, IAC-14-D2.6.10, Toronto, Canada (2014).
- [5] Yonemoto, K., Shidooka, T. and Okuda, K., "Development and Flight Test of Winged Rocket," the 27th International Symposium on Space Technology and Science, ISTS 2009-g-16, Tsukuba, Japan (2009).
- [6] Yonemoto, K., Watanabe, D., Muranaka, Y. and Miyamoto, S., "Current Status of Experimental Winged Rocket Development," 10YS341, the Proceedings of 2010 Asia-Pacific International Symposium on Aerospace Technology (Vol.2), Xian, China (2010).
- [7] Itakura, K., Miyamoto, S., Sasaki, G., Matsumoto, T. and Yonemoto, K., "Research, Development and Flight Test of Sub-scale Reusable Winged Rockets," the 13th International Space Conference of Pacific-basin Societies (ISCOPS), AAS 12-C6-2, Kyoto, Japan (2012).

- [8] Nagata, H., Ito, M., Maeda, T., Watanabe, M., Uematsu, T., Totani, T. and Kubo, I., "Development of CAMUI Hybrid Rocket to Create a Market for Small Rocket Experiments," Proceedings of the 56th International Astronautical Federation Congress, Vol. 59, No. 1-5, pp. 253-258 (2006).
- [9] Yamasaki, H., Matsumoto, T., Itakura, K., Shitaro, M. and Yonemoto, K., "Development of a Hardware-in-the-Loop Simulator and Flight Simulation of a Subscale Experimental Winged Rocket," 2013 IEEE/ASME International Conference on Advanced Intelligent Mechatronics, Wollongong, Australia (2013).
- [10] Gossamsetti, G. S., Yonemoto, K., Yamamoto, M., Choudhuri, A., R., Ishimoto, S., and Mugitani, T., "Preliminary Design of Winged Rocket Test Vehicle with Liquid Methane Propulsion System," the 30th International Symposium on Space Technology and Science, Kobe Convention Center, Kobe, Japan (2015).



**Koichi Yonemoto** was born in Tokyo in July 1953. He graduated Department of Mechanical Engineering, the Graduate School of Engineering of the University of Tokyo in 1980 and awarded Master Degree of Engineering. During the graduate school, he studied in Germany at the Institute of Aircraft Design of Faculty of Aeronautics and Astronautics of University of Stuttgart and at the Institute of Turbo Machine of German Aerospace Research Institute in Koeln from 1978 to 1980. In 1989, he received Doctor Degree of Engineering (aerospace engineering) from the University of Tokyo on the research of transonic flutter for high aspect ratio commercial aircraft.

He took a job as a research and development engineer in a Japanese major aerospace company, Kawasaki Heavy Industries, Ltd. in 1980, and engaged in a variety of research and development project, such as commercial and military aircrafts, and future space transportation system. He was a visiting researcher at the Institute of Space and Astronautical Science of Ministry of Education from 1986 to 1988 to participate in the development project of winged reusable sounding rocket. He engaged also Japanese Unmanned Space Shuttle Project HOPE (H-II Orbiting PlanE) for about ten years. After completion of the Japanese military aircraft development program of fixed-wing anti-submarine/patrol aircraft, which has the code name "P-1", as the sub-chief designer for 6 years, he left Kawasaki Heavy Industries Ltd. and started teaching space engineering as PROFESSOR at Kyushu Institute of Technology from 2005. He is the co-author of "Japanese Aerospace Handbook 3<sup>rd</sup> Edition (Japanese)" Maruzen, Japan (2005), and author of "Flight Dynamics and Controllability of Winged Reentry Vehicle: Lessons Learned," the 21st Century COE Program, International COE of Flow Dynamics Lecture Series, Volume 4, Tohoku University Press, Japan (2006). His current and previous interests are system engineering of aeronautics and astronautics, especially flight mechanics, NGC (Navigation, Guidance and Control) of aircraft and space transportation system.

Prof. Dr.-Eng. Koichi YONEMOTO is the senior member of AIAA (the American Institute of Aeronautics and Astronautics), the fellow member of JSASS (the Japan Society for Aeronautical and Space Sciences), the member of JRS (Japanese Rocket Society), the member of Japan Aeronautical Engineer's Association, and the member of UNISEC (University Space Engineering Consortium).