

# Turbine Speed Variation Study in Gas Power Plant for an Active Generator

R. Kazemzadeh, and J. M. Kauffmann

**Abstract**—This research deals with investigations on the “Active Generator” under rotor speed variations and output frequency control. It runs at turbine speed and it is connected to a three phase electrical power grid which has its own frequency different from turbine frequency. In this regard the set composed of a four phase synchronous generator and a natural commutated matrix converter (NMC) made with thyristors, is called active generator. It replaces a classical mechanical gearbox which introduces many drawbacks. The main idea in this article is the presentation of frequency control at grid side when turbine runs at variable speed. Frequency control has been done by linear and step variations of the turbine speed. Relation between turbine speed (frequency) and main grid zero sequence voltage frequency is presented.

**Keywords**—Power Generation, Energy Conversion, Frequency Control, Matrix Converter.

## I. INTRODUCTION

Now, connection of a gas turbine to a three phase generator is done by a mechanical gearbox for matching the turbine output speed to the nominal synchronous generator speed. For higher power, more than 80 MW, use and make of the gearbox becomes difficult due to safety reasons and turbine must be operated at the synchronous speed [1]. The main aim of this work is to eliminate this mechanical system in replacing by a power electronics direct drive. By this means it will be available to overcome to the fixed speed ratio of the gearbox, and obtain a fixed frequency even from variable speed of the turbine. In this state the turbine speed is not fixed by grid frequency and can be determined directly due to other mechanical or electrical constraint.

For this purpose it is possible to use a matrix converter which is a direct frequency changer without any element as intermediate and any DC link; it delivers the desired frequency with having the possibility for power flow to both side of converter due to the used bidirectional switches. Using of it in power plant permits to eliminate the start up system also. This converter normally is a force commuted converter [2], [3] and needs additional commutation circuit. Using natural commutation for this converter permits to eliminate these additional circuits and to be free from its drawback [1],

R. Kazemzadeh is with Electrical Engineering Department of Sahand University of Technology as an assistant professor (phone: 00984123459362, fax: 00984123444322, e-mail: r.kazemzadeh@sut.ac.ir).

J. M. Kauffmann is full professor at University of Franche-Comte, France in Electrical Engineering (e-mail: jean-marie.kauffmann@univ-fcomte.fr).

[4]. It is noted that because of high power consideration it is necessary to use thyristors (series and parallel) as switch and for these aims it is necessary to have at least one phase in generator more than the number of phases in output of converter, so we should have a minimum of 4 phases for the generator.

The conventional and new topologies of generation in gas power plant are shown in Fig. 1 and Fig. 2 respectively.

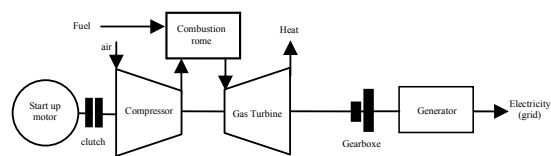

Fig. 1 Conventional gas power plant

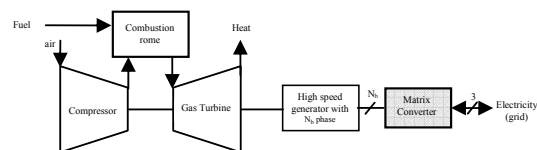

Fig. 2 Desired scheme for new gas power plant in future

Set of this four phase synchronous generator and natural commutated matrix converter (NMC) is named “Active Generator” which has really an active role on frequency conversion.

Linear and step variation of the input frequency (rotor speed) that can be due to the gas turbine speed variation has been studied and simulation results has been achieved for having a fixed frequency in grid side. By this method it is also possible to run turbine at a range of speed depending to the value of the required electrical power. Harmonic analysis gives a relation between grid zero sequence voltage, generator and grid and also commutation frequency.

## II. STUDIED SYSTEM TOPOLOGY

Connection of a four phase synchronous generator to a three phase grid through a NMC has been presented in Fig. 3. In this system the grid has been simulated by its Thevenin equivalent circuit at desired bus which will connect to output of converter or output of active generator.  $N_b$  phase synchronous generator has been modelled by the sub transient machine model defined by a sine wave electromotive source

that has two important system control parameters (phase and amplitude) [6], [7],[8] and its sub transient inductance and its phase resistance.

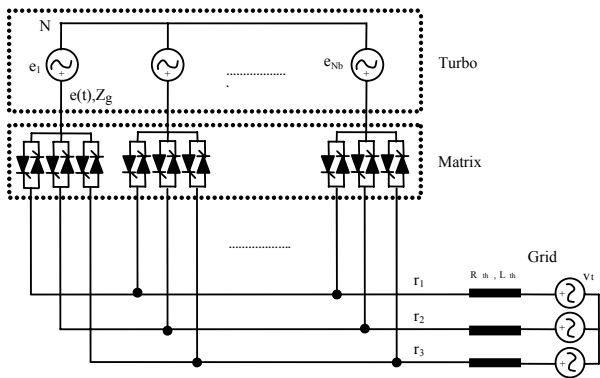

Fig. 3 Studied system topology

In this scheme commutation is done between the adjacent phases with a frequency ( $f_{com}$ ) which depends on input ( $f_r$ ) and output ( $f$ ) frequencies [1], [5].  $p$  is the number of pole pairs of the generator.

$$f_c = N_b (p * f_r - f) \tag{1}$$

The time between two commutations is defined by:

$$t_c = 1 / f_c \tag{2}$$

Some sequences of converter switching before, during and after commutation are shown in Fig. 4 by the mentioned commutation frequency for a four phase synchronous generator.

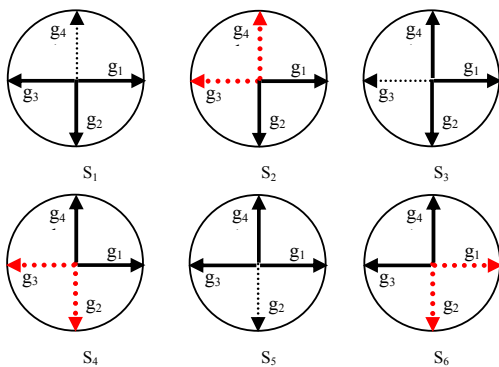

Fig. 4 Some sequences of switching

In this system, on ideal state, each grid phase is commutated every  $t_c$  from one of the  $N_b$  generator phases to another one. Then each phase of the grid is connected to one phase of generator each  $N_b t_c$ .

It is important in this new converter [1], [5], due to the use of thyristors as switch and using the natural commutation to have a free phase to be able to doing the commutations; commutations are not done in fixed and predetermined times and it makes a postpone or delay in respect to forecasted times. Then due to this phenomenon, commutation duration depends on inductance and on current where the commutation is done.

### III. FREQUENCY CONTROL DUE TO LINEAR VARIATION OF TURBINE SPEED

In this section the rotor speed or rotation frequency has been changed linearly by acting on turbine speed. By suitable control of the natural commutated matrix converter, the frequency of the converter output has been taken constant. For applying the suitable control, the commutation frequency that depends to grid and input frequency is modified in each instant to have a constant frequency in grid side; that control method and simulation results are shown in Fig. 5 and 6 respectively. These figures show the switching time modification for each commutation due to the input frequency variation.

For modelling of the linear variation of the input frequency the following form of the input frequency has been considered.

$$f_r(t) = f_{r0} \pm at \tag{3}$$

where  $a = \frac{\Delta f_r}{\Delta t}$  Hz/sec

To have the output frequency equals to the grid frequency and for fixing the output frequency of Active Generator, equation (16) has been modeled by the following equations ( $p=1$ ).

$$f_c(t) = N_b (f_{r0} \pm at - f) = (f_{c0} \pm N_b * at) \tag{4}$$

$$t_c(t) = 1 / f_c(t) = 1 / (f_{c0} \pm N_b * at) \tag{5}$$

From equation (5) it is seen that this function is a nonlinear function with respect to time. So during the simulation and during the speed variation we should modify the commutation frequency and commutation period while the commutation criteria [1] should be respected for having a safe commutation for each commutation.

The simulations has been done by considering constant the flux of the machine ( $E/f_r = cte$ ).

By this method, the commutation instant has been found through the intersection of the period of the  $n^{th}$  commutation and the line  $y=t$  that is shown in Fig. 5 or:

$$n * \frac{4}{f_c(t)} = n * \frac{4}{f_{c0} \pm at} = t \tag{6}$$

It has also been done by intersection of the commutation period and the line  $y=t/n$  for the  $n^{\text{th}}$  commutation that is presented on equation (7) and also in Fig. 6.

$$\frac{4}{f_c(t)} = \frac{4}{f_{c0} \pm at} = t/n \quad (7)$$

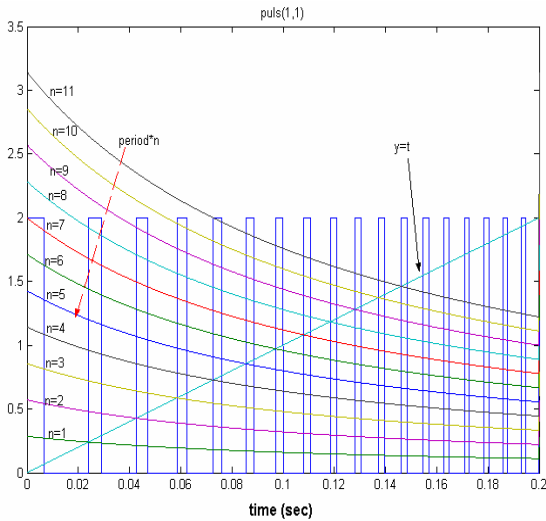

Fig. 5 Method of frequency control for determining the switching time (mode 1)

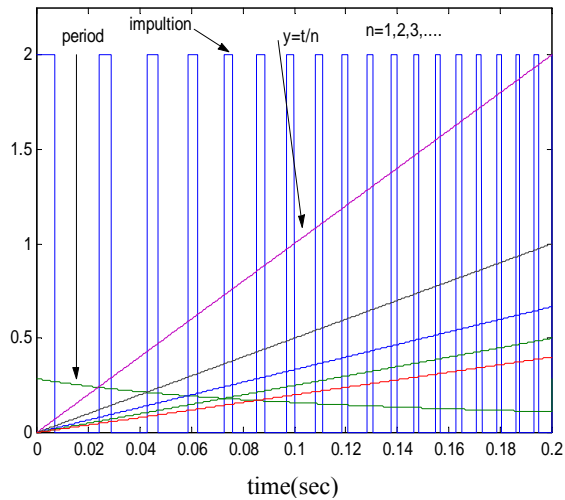

Fig. 6 Method of frequency control for determining the switching time (mode 2)

IV. FREQUENCY CONTROL DUE TO STEP VARIATION OF TURBINE SPEED

In this section the rotor speed of rotation frequency has step variations, and by suitable control of the NCMC, the frequency of the converter's output has been taken constant. By applying the suitable control the commutation frequency is modified in each instant. Fig. 7 shows turbine speed variation during time and instantaneous power at grid side due to the

variation of the input frequency.

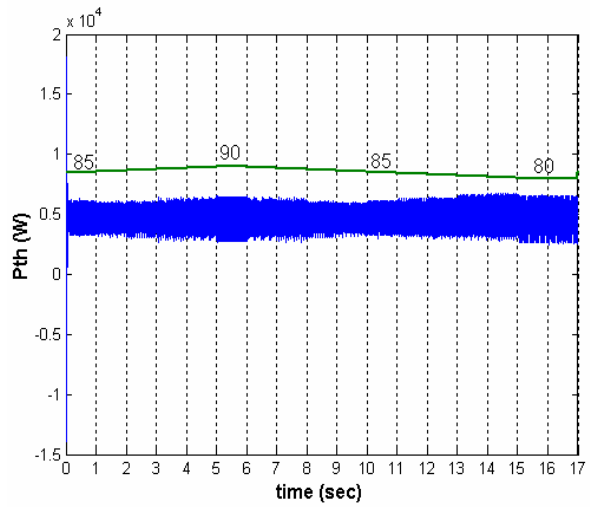

Fig. 7 Rotor frequency and Thevenin power

V. SPECIAL TURBINE SPEED FOR THIS SYSTEM

Amplitude of this oscillation depends on  $E_m$ . It has been proved that power oscillation low frequency ( $f_{p.o}$ ) follows the below equation:

$$f_{p.o} = f_c - 2f \quad (8)$$

then for a four phase generator ( $p=1$ ):

$$f_{p.o} = 4 * (f_r - f) = 4f_r - 6f$$

If  $f_{p.o}$  wants be zero it should be:

$$4f_r - 6f = 0 \text{ and}$$

$$f_r = (6/4)f$$

Then for  $f=50$  Hz,  $f_r$  must be 75 Hz. Therefore when generator frequency equals 75 Hz, the low oscillation frequency will be removed from instantaneous power, which is shown in Fig. 8. At less than 75 Hz this power also has low frequency oscillations then instantaneous power oscillation for all existing power in network is calculated by:

$$f_{p.o} = |f_c - 2f| = |4f_r - 6f| \quad (9)$$

This power oscillation frequency is drawn in Fig. 9.

As commutation frequency and converter control are determined by rotor speed, then by determination of  $f_{p.o}$  at grid side, it will be possible to determine and to estimate the rotor speed or generator frequency when the grid frequency is kept constant.

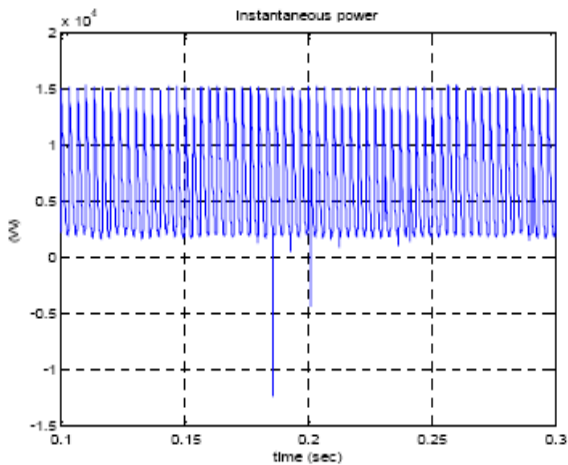

Fig. 8 Instantaneous power oscillation when  $f_r=75$  Hz

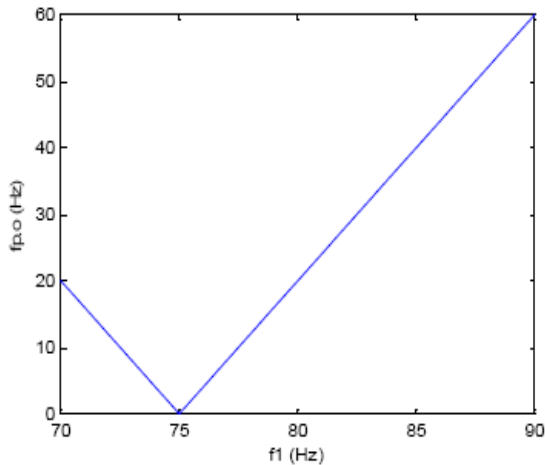

Fig. 9 Instantaneous power oscillation frequency

### VI. GRIDZERO SEQUENCE VOLTAGE FREQUENCY AND ITS RELATION WITH ROTOR SPEED

Due to the connection of the 4 phase system to 3 phase system, and by considering the star point of the generator as reference there will be a zero sequence component in grid voltage that is shown in Fig. 10.

In this section and by using the results of the step variation for the rotor speed from Fig. 8 it can be noted that for two first harmonics and in conclusion for the others there exists a relation between grid and input frequency or grid and commutation frequency and grid and low power oscillation frequency [8]. The relation is shown in (9) and (10) where  $f_r$ ,  $f$  and  $f_{com}$  are the rotor, grid and commutation frequency respectively.

For the frequency with high amplitude in frequency spectral (190 Hz in Fig. 11) it is approved that

$$f_b = f_c + f = 4f_r - 3f \quad (10)$$

And for the frequency with low amplitude in frequency spectral (230 Hz in Fig. 11) it is determined that:

$$f_a = 2f_c - f = 8f_r - 9f \quad (11)$$

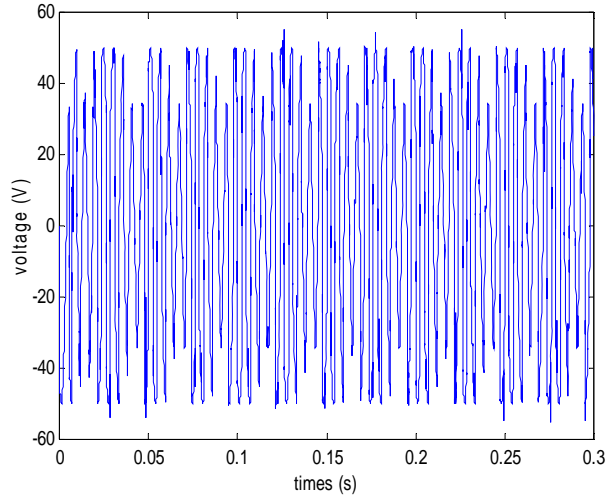

Fig. 10 Grid zero sequence voltage

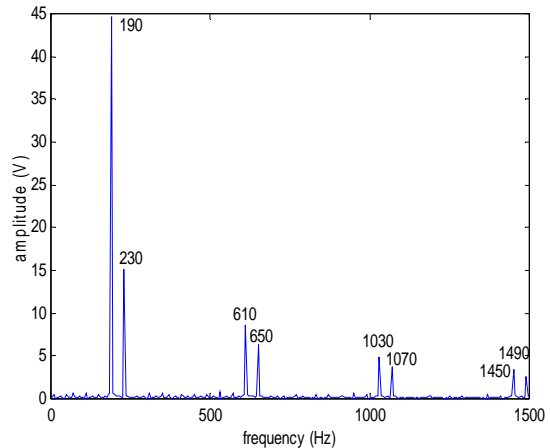

Fig. 11 Spectral analysis of grid zero sequence voltage

### VII. CONCLUSION

In this paper by presenting the new type of generation in gas power plant, the transient behavior of this system, comprising a natural matrix converter connected to a four phase synchronous generator moved, by a turbine, has been studied when the speed is varying. This variation has been done for linear and step variations under constant flux for the generator. For having the fixed needed frequency in output of the matrix converter, the control strategy of the machine converter has been determined by two methods. Simulations for this two methods show that by this control the fundamental of the output frequency is fixed in the same value as the grid frequency. This control permits to the machine to operate at

variable speed when it is connected to a three phase grid. Spectral analysis of this new machine output shows that there is an optimal rotation speed frequency that corresponds to a frequency 75 Hz; at this frequency there is not almost more fluctuation in power and the rate of distortion is definitely weaker. For grid zero sequence frequency due to this connection the related formulas corresponding to grid, generator and power oscillation have been presented, so it is possible to determine the series of existing frequency in zero sequence voltage.

#### REFERENCES

- [1] S. Turri, "Etude d'un alternateur désynchronisé," Ph.D. dissertation, Dept. Science and Technology, Franche Comté Univ., Belfort, France, 2000.
- [2] C. Klumpner, F. Blaabjerg, I. Boldea, P. Nielsen. "A New Modulation for Matrix Converters", in Proc. 36th Annual Meeting IEEE Industry Applications Society IAS 2000, volume 4, Chicago/Illinois/USA, 2001, pp. 2143-2.
- [3] Matsuo, S. Bernet, R. Stephen Colby and T. A. Lipo, "Modelling and Simulation of Matrix converter/ Induction Motor Drive", in Proc. of IMAC's, Saint Nazaire, France, 1996.
- [4] S. Turri, A. Lacaze, J. M. Kauffmann, "De-synchronized generator using a synchronous turbo-generator and a matrix converter", in Proc. IEEE international Electric Machines and Drives Conference, IEMDC'03, Volume 1, 1-4 June 2003, pp. 60 -66.
- [5] S. Turri, A. Lacaze, J. M. Kauffmann, "Matrix Converter with Natural Commutation", in Proc. International Conference on Power Electronics, Machines and Drives, University of Bath, U.K., 16-18 April 2002, pp. 183-188.
- [6] R. Kazemzadeh, J.M. Kauffmann "Power Flow Study in Connection a Generator to a Power Grid via a Natural Commutated Matrix Converter (NCMC)", in Proc. of IEEE Power Electronics Specialist Conference, PESC2004, 20-25 June, 2004, Aachen, Germany.
- [7] R. Kazemzadeh, A. Berthon, J. M. Kauffmann, "Power Exchange between a Generator and an Electrical Power Grid through a Natural Commutated Matrix Converter (NCMC)", in Proc. of EPE-PEMC2004, 2-4 Sept., Riga, Latvia.
- [8] R. Kazemzadeh, J. M. Kauffmann, "New Generation Topology in Power Plant by Using a Natural Commutated Matrix Converter", in Proc. of Powercon2004, 21-24 Nov. 2004, Singapore, Singapore.
- [9] R. Kazemzadeh, J.M. Kauffmann "Influence of the Phase Number of a Synchronous Generator Connected to a Three Phase Power Grid via a Natural Commutated Matrix Converter(NCMC)" in Proc. of ICEMS 2005, 27-29 Sept. 2005, Nanjing, China.