

Thermodynamic Evaluation of Coupling APR1400 with a Thermal Desalination Plant

M. Gomaa Abdoelatef, Robert M. Field, Lee, Yong-Kwan

Abstract—Growing human population has placed increased demands on water supplies and spurred a heightened interest in desalination infrastructure. Key elements of the economics of desalination projects are thermal and electrical inputs. With growing concerns over use of fossil fuels to (indirectly) supply these inputs, coupling of desalination with nuclear power production represents a significant opportunity. Individually, nuclear and desalination technologies have a long history and are relatively mature. For desalination, Reverse Osmosis (RO) has the lowest energy inputs. However, the economically driven output quality of the water produced using RO, which uses only electrical inputs, is lower than the output water quality from thermal desalination plants. Therefore, modern desalination projects consider that RO should be coupled with thermal desalination technologies (MSF, MED, or MED-TVC) with attendant steam inputs to permit blending to produce various qualities of water. A large nuclear facility is well positioned to dispatch large quantities of both electrical and thermal power. This paper considers the supply of thermal energy to a large desalination facility to examine heat balance impact on the nuclear steam cycle. The APR1400 nuclear plant is selected as prototypical from both a capacity and turbine cycle heat balance perspective to examine steam supply and the impact on electrical output. Extraction points and quantities of steam are considered parametrically along with various types of thermal desalination technologies to form the basis for further evaluations of economically optimal approaches to the interface of nuclear power production with desalination projects. In our study, the thermodynamic evaluation will be executed by DE-TOP, an IAEA sponsored program. DE-TOP has capabilities to analyze power generation systems coupled to desalination plants through various steam extraction positions, taking into consideration the isolation loop between the nuclear and the thermal desalination facilities (i.e., for radiological isolation).

Keywords—APR1400, Cogeneration, Desalination, DE-TOP, IAEA, MED, MED-TVC, MSF, RO.

I. INTRODUCTION

FRESH water availability drives economic development. Limited availability of fresh water can significantly constrain human activities. Nearly three-quarters of the earth's surface is covered with water. The estimated total volume of this water is $1.3 \times 10^{18} \text{ m}^3$. However, 97.5% of this amount is represented by the oceans, which are highly saline and unfit for human consumption. Of the remaining 2.5%, a major portion is locked up in polar ice and glaciers. On balance, less than 1% is available for human use. It is estimated that the amount of fresh

water that is readily accessible is about $9 \times 10^{12} \text{ m}^3$ while another $3.5 \times 10^{12} \text{ m}^3$ is captured and stored by dams and reservoirs [1].

Seawater desalination as a source of fresh water has expanded since early projects in the 1950s. Today it represents a critical resource for many countries, particularly in the Middle East (e.g., the United Arab Emirates (UAE), Israel, and the Kingdom of Saudi Arabia).

Like all industrial processes, desalination requires energy inputs. Using fossil energy resources raises environmental concerns associated with CO_2 emissions. Moreover, fossil fuel supplies for transportation are vital with few viable alternatives. Nuclear desalination thus represents a solid approach to providing energy while meeting environmental demands.

Nuclear desalination as defined by IAEA is, “the production of potable water from sea water in a facility in which a nuclear reactor is used as the source of energy for the desalination process.” Electrical and/or thermal energy may be used in the desalination process. The facility may be dedicated solely to the production of potable water, or may be used for the generation of electricity and the production of potable water, in which case only a portion of the total energy output of the reactor is used for water production.” In either case, the notion of nuclear desalination is taken to mean an integrated facility in which both the reactor and the desalination system are located on a common (or abutting) site(s) and energy is produced on-site for use in the desalination system. It also involves at least some degree of common or shared facilities, services, staff, operating strategies, outage planning, controls facilities, and seawater intake and outfall structures [1].

In December 2009, the Emirates Nuclear Energy Corporation (ENEC) announced that it had selected a bid from the Korea Electric Power Corporation (KEPCO) for four Advanced Pressurized Nuclear Reactor APR1400 reactors, to be built at one site [2].

UAE is one of the Gulf countries, which has a shortage of fresh water. Conditions like this give rise to the idea of coupling desalination facilities with the APR1400.

Mussie S. Naizghi and Waka G. Tesfay (2011) studied the techno-economic feasibility study of coupling Multi Effect Distillation (MED), Multi Stage Flushing (MSF), and Reverse Osmosis (RO) desalination plants to the APR1400. The study was performed using the Desalination Economic Evaluation Program, DEEP 3.2. This program provides approximate water and electricity costs for different co-generation coupling options for a range of desalination technologies. The study compared the coupling between desalination plants and two power plants: the APR 1400 and a combined cycle gas turbine plant CC-1400 [3].

M. Gomaa Abdoelatef is a Student at the KEPCO International Nuclear Graduate School (KINGS), Ulsan, South-Korea (phone: +821053900229; e-mail: gomaa2020@gmail.com).

Robert M. Field and T. C. Yonkwan Lee are Associate Professors at KINGS, Ulsan, South-Korea (e-mail: rmfield@kings.ac.kr, leeyk@kings.ac.kr).

Gustavo Alonso and Samuel Vargasa (2012) studied the cogeneration of electricity and potable water from desalination based on big or small/medium reactors. The study examined the economics of nuclear desalination using two PWR (pressurized water reactor) designs, large size, the AP1000, against an intermediate size, IRIS. The study assessed electricity and potable water needs for the northwest region of Mexico. Alternatives using the three desalination processes, reverse osmosis (RO), multi-stage flash distillation (MSF) and multi-effect distillation (MED), and two hybrid methods were presented [4].

Li Weihua, Zhang Yajun, and Zheng Wenxiang (2012) studied coupling the NHR-200 with three kinds of desalination processes: (i) low-temperature horizontal tube MED-TVC, (ii) high-temperature stacked VTE-MED, and (iii) a hybridization of reverse osmosis and MED. The assigned capacities of the fresh water production were 107,500 m³/d, 160,000 m³/d, and 250,000 m³/d, respectively. The paper presented the main features of the reactor, interface considerations between the reactor and desalination plant, and preliminary economic analysis results [5].

This paper will perform a sensitivity analysis for coupling the APR1400 to a range of thermal desalination technologies. The technologies are: (i) Multi-Stage Flashing (MSF), (ii) Multi-Effect Distillation (MED), and (ii) hybrid Multi-Effect Distillation and Thermal Vapour Compression (MED-TVC).

For each technology, the study will consider a range of plant capacities (production of fresh water), varied from 25,000 to 150,000 m³/day. In addition, different steam extraction locations in the APR1400 turbine cycle will be considered.

This study will use the International Atomic Energy Authority (IAEA) Desalination Thermodynamic Optimization Program (DE-TOP). This program was developed as a tool for thermodynamic analysis of coupled nuclear power and seawater desalination plants. I.G. Sánchez-Cervera, K.C. Kavvadias, and I. Khamis (2011) previously used this software (DE-TOP) for analyzing different coupling options including various alternatives of steam extractions [6]. This study reported advantages and disadvantages of each coupling option.

II. DESALINATION TECHNOLOGIES

There are two major types of desalination technologies. These can be broadly classified as either: (i) thermal desalination processes, in which feedwater is boiled and the vapor condensed as pure water (distillate), or (ii) membrane desalination processes, in which semi-permeable membranes are used to separate out the dissolved solids. Both technologies need energy to operate. Within these two types there are sub-categories (processes) using different techniques [7], as indicated per Fig. 1.

Fig. 2 shows the operating global desalination plant capacity by technology as of 2012 [7]. Worldwide, the number of installed facilities has increased to more than 15,000 spanning 125 countries. Over time, the production cost of RO sourced water obtained has decreased (e.g., from \$1.92/m³ at Catalina Island, California (1990), to \$0.47/m³ at Tuas, Singapore (2003)). It is also cautioned that production costs can vary

widely by region [7].

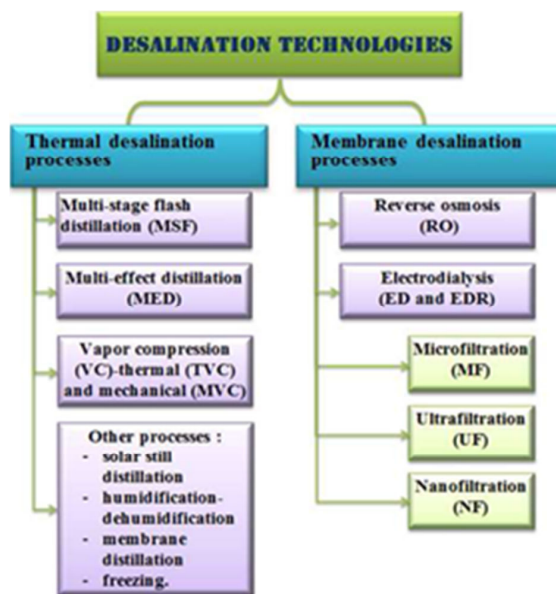

Fig. 1 Classification of desalination technologies [7]

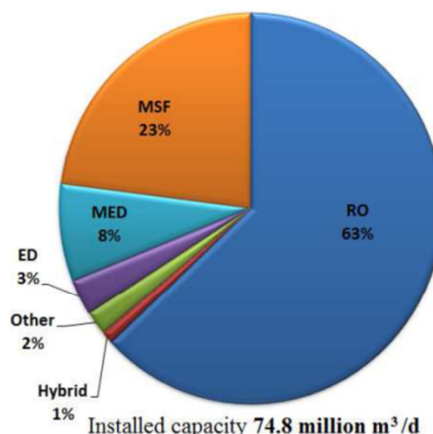

Fig. 2 Global desalination plant capacity by technology [7]

Energy inputs to RO plants are almost exclusively in the form of electrical power (i.e., to derive the high-pressure RO pumps and other plant auxiliaries). Net RO power consumption depends mainly on water recovery, pressure recovery, and the working pressure for the process. The percentage of recovered energy increases as the plant size increases due to increase investment in water turbine technology.

Electrical energy inputs are roughly 4.5 to 7 kWh/m³ for the RO process. About 85% of this energy is required for the high-pressure pumps. Energy inputs depend on the design, unit size, site conditions, water quality requirements, membrane properties, the feed temperature and salinity, and usage of energy recovery systems [8].

Waste heat from the nuclear unit can be used to improve the efficiency of the RO plant. An increase in the feed temperature can lead to higher RO membrane flux and thus produce more

product water using the same installed capacity (e.g., membrane area). Pre-heating of feed (e.g., using heat from the circulating water discharge) can marginally improve RO efficiencies but maximum pre-heat temperatures are limited [8].

For the RO process, the coupling with the power plant is only for the supply of electricity, not steam. Since electricity is fungible, with minimal losses associated with grid transmission, the economics of coupling an RO plant to the APR1400 are not different from the stand-alone economics of electricity production. Therefore, the case of APR1400 coupled with RO is not examined.

III. NUCLEAR DESALINATION

A. Useful Definitions

Terminology is first introduced to better define and clarify the remaining analysis.

- Brackish water: water containing low concentrations of soluble salts, typically between 1,000 and 10,000 mg/L.
- Salinity: the concentration of dissolved salts in water.
- Total Dissolved Solids (TDS): the weight per unit volume of all volatile and non-volatile solids dissolved in a water or wastewater after a sample has been filtered to remove colloidal and suspended solids.
- Top Brine Temperature (TBT): the maximum temperature of the fluid being evaporated in an evaporator system.
- Brine: water saturated with, or containing a high concentration of salts, usually in excess of 36,000 mg/L.
- Gain Output Ratio (GOR): a measure of evaporator performance representing the ratio of mass flow of distillate to steam input.
- Latent heat: the heat required to cause a change of state at constant temperature, such as the vaporization of water, or the melting of ice.
- Hybrid: a system incorporating multiple processes or technologies (e.g., a desalination facility incorporating both thermal and membrane processes). Generally hybrid technologies should at least be partially integrated for some process benefit to qualify as 'hybrid' [9].

B. Nuclear Desalination Definition

Nuclear desalination can be defined as an integrated facility in which both the reactor and the desalination system are located on a common (or adjacent) site(s) with energy produced on-site for use in the desalination system. It also involves at least some degree of common or shared facilities, services, staff, operating strategies, outage planning, etc. [10].

Nuclear desalination can be a viable option as a sustainable source of water and electric power. Nuclear power is a mature technology with more than 400 operating reactors accounting for more than 16% of global electricity production.

Experience gained in the operation of the units can be shared globally, and in particular, with developing countries interested in cogeneration of power and water. Several field studies of nuclear power plants as well as nuclear desalination are currently underway. Examples can be found in Indonesia, Argentina, Tunisia, Pakistan, India, Morocco, Egypt, Russia, and China. The IAEA, for instance, has been engaged in international projects in several of the above countries, facilitating research and development of present and foreseen future nuclear desalination activities [11].

Technical feasibility of integrated nuclear desalination had been demonstrated in Kazakhstan and Japan for many years. Their successful operation has proved the technical feasibility, compliance with safety requirements and reliability of cogeneration nuclear reactors. Table I shows the summarization of past and present experiences with nuclear desalination.

C. Steam and Power Supply

Nuclear units can efficiently supply both power and steam to a desalination facility. Note that steam from the Nuclear Steam Supply System (NSSS) has energy content which is too high for efficient use in the desalination process. Therefore, this steam is first passed through a portion of the steam flow path in the main turbine before being extracted for use in the combined cycle. The optimal point for extracting this steam from the turbine cycle is of interest in this study [3].

A comprehensive review of cogeneration literature studies provides guidance for assessing cogeneration options in the current study [11].

TABLE I
SUMMARY OF PAST AND PRESENT EXPERIENCE WITH NUCLEAR DESALINATION [3]

Reactor Type	Location	Desalination Process	Status
LMFR	Kazakhstan	MED, MSF	Operated Between 1973-199
PWRs	Japan (Fukui, Ehime, Saga)	MSF, MED, & RO	Over 150 reactor years of operation since 1974 with over 10 nuclear desalination facilities at a capacity between 1000-3000 m ³ /d each
BWR	Japan (Niigata)	MSF	Not in operation
PWR	USA (Diablo Canyon, CA)	RO	Operating since 1992 at a capacity of 2500 m ³ /d
PHWR	India (Kalpakkam)	MSF/RO	Demonstration plant, capacity 6300m ³ /d in service since 2004.
PHWR	Pakistan	MED	Existing CANDU nuclear power reactor modified to be coupled to an MED plant as a demonstration plant
NHR200	China (Shandong Peninsula)	MED	Under design, capacity of 160,000m ³ /d
PWR	Russia (Severodvinsk)	MED, RO	Under Consideration, Floating unit
HTRs	France, the Netherlands, South Africa.	MED, RO	Under consideration

Since a portion of the desalination product stream will be used as potable water, avoidance of cross (radioactive) contamination must be a basic principle of the design. Accepted design principals dictate that at two mechanical barriers between the reactor primary coolant and product stream (e.g., heated brine) must be incorporated. In the case of a Pressurized Water Reactor (PWR), the steam generator serves as the first barrier [12].

Fig. 3 illustrates schematically the coupling of an MSF plant with a PWR. Note that an intermediate heat exchanger is included as an additional isolation loop.

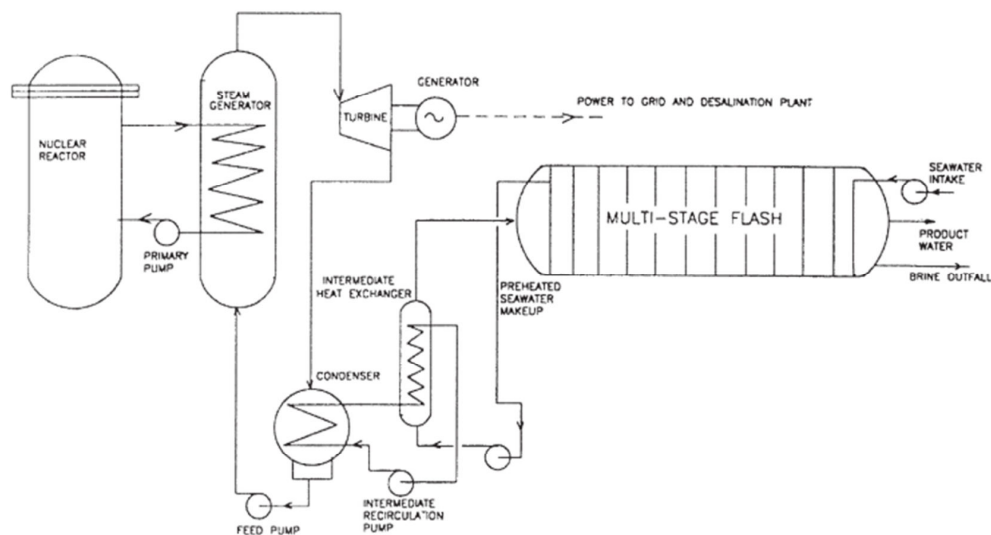

Fig. 3 Schematic diagram – PWR to MSF [1]

IV. BRIEF DESIGN DESCRIPTION OF THE APR1400

The Advanced Power Reactor 1400 (APR1400) is an evolutionary advanced light water reactor (ALWR). Based on the Optimized Power Reactor 1000 (OPR1000), the APR1400 incorporates a variety of engineering improvements and operational experience to enhance safety, economics, and reliability. Safety improvements included in the APR1400 design include: (i) a pilot operated safety relief valve (POSRV), (ii) a four-train safety injection system, (iii) direct vessel injection (DVI), (iv) a fluidic device (FD) in the safety injection tank, (v) an in-containment refuelling water storage tank (IRWST), (vi) an external reactor vessel cooling system, and (vii) an integrated head assembly (IHA). Development of the APR1400 started in 1992 and continued for ten years. The APR1400 design received design certification from the Korean nuclear regulatory body in May of 2002 [13].

The APR1400 is licensed for 3981 MWt (core). The NSSS contains two primary coolant loops, each of which has two reactor coolant pumps, a steam generator, a 42-inch ID hot leg pipe and two 30-inch ID cold leg pipes. The pressuriser has an increased volume (relative to previous design) to enhance transient response. APR1400 design parameters are listed in Table II [14].

V. DESALINATION THERMODYNAMIC OPTIMIZATION PROGRAM DE-TOP OVERVIEW

The IAEA developed DE-TOP as a tool for the thermodynamic analysis and optimization of nuclear cogeneration systems. DE-TOP models the steam cycle (Rankine cycle) cycle of different water cooled reactors or fossil plants, and the connection between any non-electrical applications. Users are able to select different coupling arrangements between power plant and non-electric application (single steam extraction, multiple steam extraction, back pressure operation, etc.).

DE-TOP calculates energy and exergy flows of the cogeneration system and produces detailed reports for plant performance for different cogeneration modes.

The main features of DE-TOP are:

- Base-load calculations of mass and energy flows in the power plant secondary cycle,
- Modelling of water/steam thermodynamic properties (T, P, enthalpy, exergy, etc.) based on the IAPWS-IF97 industrial formulation,
- Customizable parameters for water cooled reactors and fossil steam power plants to fit any user defined case, including several predefined cases (PWR, BWR, SMRs, etc.),

- Simulation operation with of non-electric applications such as desalination, district heating or process heat, and
- Reporting and analysis of plant performance in single electricity production and cogeneration modes [15].
- Fig. 4 illustrates the turbine cycle arrangement for the APR1400 (i.e., six (6) flow low pressure turbine, two stages of reheat, with seven (7) points of feedwater heating including a deaerator) [14].

Table III shows the input data for the desalination plants including the minimum required steam (the extracted steam to feed the desalination plant) temperature (i.e., as calculated by DE-TOP based on the TBT and the isolation loop requirements).

TABLE II
APR1400 DESIGN AND PERFORMANCE CHARACTERISTICS [14]

Parameter	Value
<i>Principal Design Parameters for the Reactor Coolant System</i>	
Operating Pressure, psia	2250
Reactor Inlet Temperature, °F	555
Reactor Outlet Temperature, °F	615
Number of Loops	2
Design Pressure, psia	2500
Design Temperature, °F	650
Total Coolant Volume, ft ³	16019.7
Total Reactor Flow, gal/min	446,300
<i>Principal Design Parameters of the Steam Generators</i>	
Tube material	SB-163 Alloy 690
Tube Side Design Pressure, psia	2500
Tube Side Design Temperature, °F	650
Tube Side Design Flow, lb/hr per steam generator	83.3 x 10 ⁶
Shell Side Design Pressure, psia	1200
Shell Side Design Temperature, °F	570
Operating Pressure, Tube Side, Nominal, psia	2250
Operating Pressure, Shell Side, Maximum, psia	1100
Maximum Moisture at Outlet at Full Load, %	0.25
Main Steam System design pressure/temperature	1200 psia (83 kg/cm ²) 570°F (299 °C)
Main steam system operating pressure/temperature (at steam generator steam nozzle outlets)	1000 psia (69 kg/cm ²) 544 °F (284 °C)
Main steam flow	17.95 x 10 ⁶ lb/hr (8.14 x 10 ⁶ kg/hr)
Final feedwater temperature	450°F (232 °C)
Final feedwater flow	17.99 x 10 ⁶ lb/hr (8.16 x 10 ⁶ kg/hr)

TABLE III
THE INPUT DATA FOR DESALINATION PLANTS

Parameters	Units	MSF	MED	MED-TVC
Total dissolved solids (TDS)	--	45000	45000	45000
Top Brine Temp.	°C	115	75	70
Cooling water temp	°C	25	25	25
Minimum requirement steam temp. (Calculated by DE-TOP)	°C	125.5	85.5	136.8

VI. RESULTS AND ANALYSIS

The study here presents a comparison of different types of thermal desalination technology (MSF, MED, and MED-TVC), coupled to the APR1400. Parametric variation includes a range

of capacity (25, 50, 75, 100, 125, and 150 Km³/day) for each desalination technology, along with different points of steam extraction from the nuclear steam cycle.

TABLE IV
APR1400 POWER PLANT SINGLE PURPOSE PARAMETERS (DE-TOP OUTPUT)

Parameters	Units	MSF
<i>Main Parameters</i>		
Total Power Req. for Desalination	MWe	0
Power lost Ratio	%	0
Net Efficiency	%	36.3
Cogeneration Plant Efficiency	%	36.3
<i>Extracted Steam to Desalination</i>		
Heat to Desalination	MWth	0
Steam Temperature	°C	0
Steam Pressure	bar	0
Amount of Steam	Kg/s	0
<i>Plant Performance</i>		
Gross Power Output	MWe	1451
Net Output	MWe	1400.2
Heat Rejected to Condenser	MWth	2390
Steam Inlet to LP Turbine	Kg/s	1679.2
LP Turbine Exhaust	kg/s	1194.2
<i>Intermediate Loop</i>		
IL Mass Flow	Kg/s	0

The isolation loop (essential for safety and hazard protection) between the APR1400 power plant and the desalination plant will be defined through the DE-TOP program.

Table IV shows the APR1400 power plant single purpose parameters (output data from DE-TOP) for comparison to the APR1400 co-generation options. Fig. 5 indicates the extraction points from the APR1400 steam cycle.

Tables V-VII provide comparison of the APR1400 single purpose and co-generation as coupled with various options. The tables correspond to the MSF, MED, and MED-TVC coupling options, respectively. The MSF and MED-TVC make use of extraction steam option 4 while the MED makes use of extraction steam option 5.

VII. DISCUSSION

Tables V-VII present a thermodynamic evaluation for APR1400 single purpose and cogeneration options (coupled with MSF, MED, and MED-TVC, respectively).

Fig. 6 compares the reduction of APR1400 net Efficiency associated with coupling a considered range of desalination capacities.

Certain measures can provide salient input to decision making regarding the preferred coupling configuration. Parameters of interest include the following:

A. Thermal Utilization (Cogeneration Plant Efficiency)

Due to the synergies involved, cogeneration systems have increased overall efficiency. An index that is frequently used to characterize the performance of a cogeneration system is the Thermal Utilization factor (TU). TU indicates the percentage of primary energy utilized by the end user expressed as:

$$TU = (W+Q_U)/F$$

where; W is work produced by the power plant; Q_U is the useful

heat delivered to the desalination plant, and F is the energy in the fuel supplied to the dual-purpose plant.

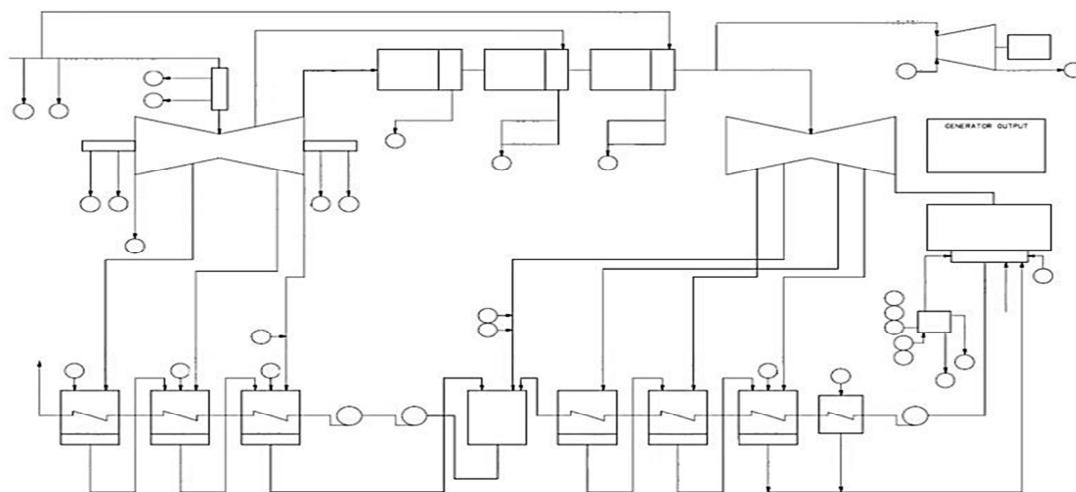

Fig. 4 APR1400 turbine cycle arrangement [14]

B. Total Power Requirements

The increased efficiency for cogeneration comes with a cost. The steam extracted for the thermal desalination plant causes a drop in power generation which is strongly dependent the extraction conditions. The design and performance of the auxiliary equipment of the thermal desalination plant also plays an important role. Total power requirements include electric power generation reduction in the power plant due to reduced steam flow through the turbine and electric consumption of

auxiliary loads in the water plant (e.g., pumping and other duties).

The reduction in power plant turbine stage group efficiency due to reduced steam mass flow is not significant for the relatively small amount of steam extraction. Therefore this effect is not modeled by DE-TOP. However this effect is analogous to the reduction in turbine efficiency for part load operation [15].

TABLE V
APR1400 WITH MSF - SINGLE PURPOSE VS. CO-GENERATION

Parameters	Units	APR1400	25,000 m3/day	50,000 m3/day	75,000 m3/day	100,000 m3/day	125,000 m3/day	150,000 m3/day
<i>Main Parameters</i>								
Total Power Req. for Desalination	MWe	0	20.4	37.9	55.4	72.9	90.3	107.8
Power lost Ratio	%	0	21	21	21	21	21	21
Net Efficiency	%	36.3	35.9	35.6	35.2	34.8	34.5	34.1
Cogeneration Plant Efficiency	%	36.3	37.7	39.1	40.5	41.8	43.2	44.6
<i>Extracted Steam to Desalination</i>								
Heat to Desalination	MWt	0	67.57	135.14	202.71	270.28	337.85	405.42
Steam Temperature	°C	0	144	144	144	144	144	144
Steam Pressure	bar	0	1.04	1.04	1.04	1.04	1.04	1.04
Amount of Steam	kg/s	0	32.6	65.2	97.8	130.4	163.1	195.7
<i>Plant Performance</i>								
Gross Power Output	MWe	1451	1436.1	1421.2	1406.3	1391.5	1376.6	1361.7
Net Output	MWe	1400.2	1385.8	1371.5	1357.1	1342.8	1328.4	1314
Heat Rejected to Condenser	MWt	2390	2337	2285	2232	2180	2127	2075
Steam Inlet to LP Turbine	kg/s	1679.2	1679.2	1679.2	1679.2	1679.2	1679.2	1679.2
LP Turbine Exhaust	kg/s	1194.2	1168	141.7	1115.5	1089.2	1063	1036.7
<i>Intermediate Loop</i>								
IL Pumping Power	MWe	0	0.23	0.46	0.68	0.91	1.14	1.37

C. Power Lost Ratio

The power lost is the difference between the power outputs of the reference plant (WT_{Ref}) and the power output of the cogeneration plant (WT_{Cogen}) by means of:

$$\Delta W = (WT_{Ref} - WT_{Cogen})$$

For the comparison of different systems it is useful to calculate the power lost ratio, which is defined as the power lost

in the power plant to the amount of heat delivered for the desalination plant (e.g. a power lost ratio of 10% implies that for each 100 MWt extracted the net nominal power output is decreased by 10 MWe).

$$\text{Power lost ratio} = \frac{\text{Power lost}}{\text{Useful heat}}$$

D. Desalination plant module

The Gain Output Ratio (GOR) can be estimated for MSF plants as:

$$GOR = \frac{\lambda_h}{C_h \cdot (\Delta T_{bh} + \Delta T_{bpe})} \cdot (1 - e^{-C_{vm} \frac{\Delta T_{ao}}{\lambda_m}})$$

where; λ_h - latent heat of heating vapor, kJ/kg, λ_m - average latent heat of water vapor in MSF stages, kJ/kg, C_h - specific heat capacity of feed in brine heater, kJ/kg/K, C_{vm} - average specific heat capacity of brine in MSF plant, kJ/kg/K, ΔT_{bh} - Brine heater feed temperature gain for MSF, °C, ΔT_{bpe} - Boiling point elevation, °C, ΔT_{ao} - Overall working temperature range, °C, ΔT_{ae} - Average temperature drop per effect, °C, ΔT_{ph} - Preheating feed temperature gain, °C.

The GOR is estimated for MED plants as the number of effects times the efficiency of the plant. DE-TOP uses a default

value for MED efficiency of 0.8. The number of effects can be estimated given the cooling water temperature, the top brine temperature and the average temperature drop between stages as:

$$\Delta T_{ao} = T_{mb} - (T_{cw} + \Delta T_{reject})$$

$$N_{emed} = \Delta T_{ae} / \Delta T_{ao}$$

where; ΔT_{ao} - Overall water plant working temperature, °C, N_{emed} - Number of MED stages, T_{mb} - Top brine temperature, °C, T_{cw} - Cooling water temperature, °C, ΔT_{reject} - Reject / cooling stage range in the distillation plant, °C, ΔT_{ae} - Average temperature drop between stages.

For the case of thermal vapor compression units coupled to MED (MED-TVC) systems, the GOR model is generalized as:

$$GOR_{TVC} = GOR \cdot (1 + R_{TVC})$$

where; R_{TVC} - ratio of entrained vapor flow to motive steam flow.

DE-TOP uses a default value for R_{TVC} close to unity [15]. Table VIII lists GOR for the APR1400 coupled to the considered thermal desalination technologies.

TABLE VI
APR1400 WITH MED - SINGLE PURPOSE VS. CO-GENERATION

Parameters	Units	APR1400	25,000 m3/day	50,000 m3/day	75,000 m3/day	100,000 m3/day	125,000 m3/day	150,000 m3/day
<i>Main Parameters</i>								
Total Power Req. for Desalination	MWe	0	11	20.3	29.6	38.9	48.2	57.5
Power lost Ratio	%	0	14	14	14	14	14	14
Net Efficiency	%	36.3	36.1	35.9	35.7	35.5	35.4	35.2
Cogeneration Plant Efficiency	%	36.3	37.5	38.6	39.8	41	42.1	43.3
<i>Extracted Steam to Desalination</i>								
Heat to Desalination	MWt	0	52.32	104.64	156.95	209.27	261.59	313.91
Steam Temperature	°C	0	100	100	100	100	100	100
Steam Pressure	bar	0	1.03	1.03	1.03	1.03	1.03	1.03
Amount of Steam	kg/s	0	25.4	50.7	76.1	101.5	126.8	152.2
<i>Plant Performance</i>								
Gross Power Output	MWe	1451	1443.3	1435.6	1427.8	1420.1	1412.1	1404.7
Net Output	MWe	1400.2	1392.8	1385.3	1377.9	1370.4	1363	1355.5
Heat Rejected to Condenser	MWt	2390	2345	2301	2256	2212	2167	2123
Steam Inlet to LP Turbine	kg/s	1679.2	1679.2	1679.2	1679.2	1679.2	1679.2	1679.2
LP Turbine Exhaust	kg/s	1194.2	1172	1149.7	1127.5	1105.2	1083	1060.7
<i>Intermediate Loop</i>								
IL Pumping Power	MWe	0	0.18	0.35	0.53	0.7	0.88	1.06

VIII. CONCLUSION

Presented here is thermodynamic analysis for a set of configurations coupling the APR1400 to thermal desalination technologies. The DE-TOP program was used for the analysis. Results can be used as input to detailed cost analysis for selecting the optimal technology for cogeneration of energy and water. Results of this study indicate that the optimal extraction positions are No. 4 for MSF and MED-TVC, and No.5 for MED. These extraction positions are the best positions to: (i) maximize the net efficiency of the APR1400, (ii) reduce the

total power required to the desalination process, and (iii) minimize the amount of steam extracted to feed the desalination plant.

Detailed design of the components and piping systems required to interface the thermodynamic cycles addressed here was not a part of this study. However, it is believed that the various arrangements will require comparatively low investment and these systems can be expected to have good reliability and efficiency when operated at rated capacity (e.g., minimal pressure drop and good approach temperature).

TABLE VII
GOR AND INTERMEDIATE LOOP PARAMETERS FOR MSF, MED, & MED-TVC
COUPLED WITH APR1400.

Parameters	Unit	MSF	MED	MED-TVC
<i>Desalination Technologies</i>				
Total dissolved solids (TDS)	--	45000	45000	45000
Top Brine Temp.	°C	115	75	70
Cooling water temp	°C	25		
Min. req. steam temp.	°C	125.5	85.5	136.8
GOR	--	9.5	12.8	22.4
<i>Intermediate loop</i>				
IL Hot Temp	°C	125.5	85.5	80.5
IL Condenser Return Temp	°C	117	77.5	72.5

The overall economic comparison of appropriate technologies for cogeneration of electricity and water involves both the operating efficiency metrics addressed here and cost considerations involving capital, operations, and maintenance for the proposed technologies. Capital costs include the cost of: (i) the energy production facility (e.g., PWR), (ii) the water production facility (e.g., MED-TV), and (iii) the interfacing facility to transfer energy and water between facilities (i.e., brine heater). The evaluations presented here provide a detailed methodology to quantify energy efficiency inputs and metrics for the overall cost analysis of considered options.

TABLE VIII
A COMPARISON BETWEEN APR1400 SINGLE PURPOSE AND CO-GENERATION WITH MED-TVC

Parameters	Units	APR1400	25,000 m3/day	50,000 m3/day	75,000 m3/day	100,000 m3/day	125,000 m3/day	150,000 m3/day
<i>Main Parameters</i>								
Total Power Req. for Desalination	MWe	0	13	22.7	32.5	42.2	52	61.8
Power lost Ratio	%	0	21	21	21	21	21	21
Net Efficiency	%	36.3	36.2	36	35.8	35.7	35.5	35.3
Cogeneration Plant Efficiency	%	36.3	36.9	37.5	38.2	38.8	39.4	40
<i>Extracted Steam to Desalination</i>								
Heat to Desalination	MWt	0	30.1	60.1	90.2	120	150	180
Steam Temperature	°C	0	144	144	144	144	144	144
Steam Pressure	bar	0	1.04	1.04	1.04	1.04	1.04	1.04
Amount of Steam	kg/s	0	14.5	29	43.5	58	72.5	87
<i>Plant Performance</i>								
Gross Power Output	MWe	1451	1444.4	1437.7	1431.1	1424.5	1417.9	1411.3
Net Output	MWe	1400.2	1393.8	1387.4	1381	1374.6	1368.3	1361.9
Heat Rejected to Condenser	MWt	2390	2366	2343	2320	2296	2273	2250
Steam Inlet to LP Turbine	kg/s	1679.2	1679.2	1679.2	1679.2	1679.2	1679.2	1679.2
LP Turbine Exhaust	kg/s	1194.2	1182.6	1170.9	1159.2	1147.5	1135.8	1124.2
<i>Intermediate Loop</i>								
IL Pumping Power	MWe	0	0.1	0.2	0.3	0.41	0.51	0.61

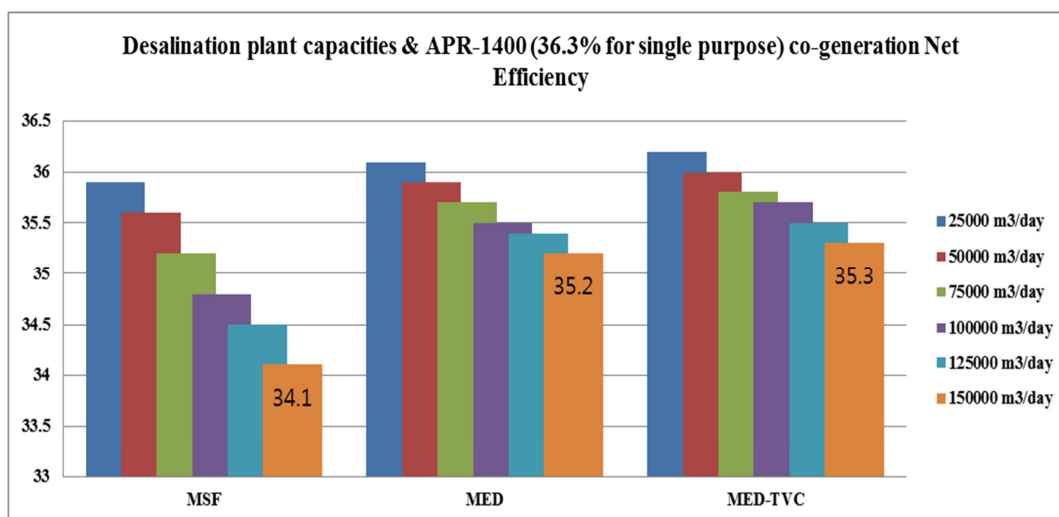

Fig. 5 APR1400 efficiency vs. desalination technology

ACKNOWLEDGMENT

This research was supported by the 2015 research fund of the KEPCO International Nuclear Graduate School (KINGS), Republic of Korea.

REFERENCES

- [1] Introduction to Nuclear Desalination: A Guidebook, Technical Report Series Number 400, International Atomic Energy Agency, Vienna, 2000.
- [2] World Nuclear Association, <http://www.world-nuclear.org/info/Country-Profiles/Countries-T-Z/United-Arab-Emirates/> Nuclear Power in the United Arab Emirates, March. 2015.
- [3] Mussie S. Naizghi, Waka G. Tesfay, and Hassan E.S. Fath, "Nuclear Desalination and its Viability for UAE," The Sharjah international conference on nuclear and renewable energies for the 21st century, SHJ-NRE, March. 2011.
- [4] Gustavo Alonso, Samuel Vargas, Edmundo del Valle, Ramon Ramirez, "Alternatives of seawater desalination using nuclear power," in Nuclear Engineering and Design 245 (2012) 39– 48, January. 2012.
- [5] Li Weihua, Zhang Yajun, and Zheng Wenxiang, "Investigation on three seawater desalination processes coupled with NHR-200" Desalination 298 (2012) 93–98, June. 5, 2012.
- [6] I.G. Sánchez-Cervera, K.C. Kavvadias, I. Khamis, "DE-TOP: A new IAEA tool for the thermodynamic evaluation of nuclear desalination" Desalination 321 (2013) 103–109, Nov. 9, 2011.
- [7] New Technologies for Seawater Desalination Using Nuclear Energy: A Guidebook, Technical Report IAEA-TECDOC-1753, Vienna, 2015.
- [8] Ibrahim S. Al-Mutaz, "Coupling of a nuclear reactor to hybrid RO-MSF desalination plants" Desalination 157 (2003) 259–268, February. 2003.
- [9] Desal glossary, <http://www.desalination.com/market/desal-glossary> Water Desalination Report.
- [10] M.M. Megahed, "Nuclear desalination: history and prospects," Desalination, vol. 135, Apr. 2001, pp. 169-185.
- [11] Ron S. Faibisha and Hisham Ettouney, "MSF nuclear desalination," Desalination, vol. 157, Jan. 2003, pp. 277-287.
- [12] Status of design concepts of nuclear desalination plants, Technical Report IAEA-TECDOC-1326, International Atomic Energy Agency, Vienna, 2002.
- [13] Sang-Seob Lee et al, The Design Features of The Advanced Power Reactor 1400, Nuclear Engineering and Technology, Vol 41 no 8, October 2009.
- [14] Korea Hydro & Nuclear Power Company, "Standard Safety Analysis Report for APR1400".
- [15] International Atomic Energy Agency, Nuclear Desalination (Online), International Atomic Energy Agency, 2011, <http://www.iaea.org/NuclearPower/Desalination/>

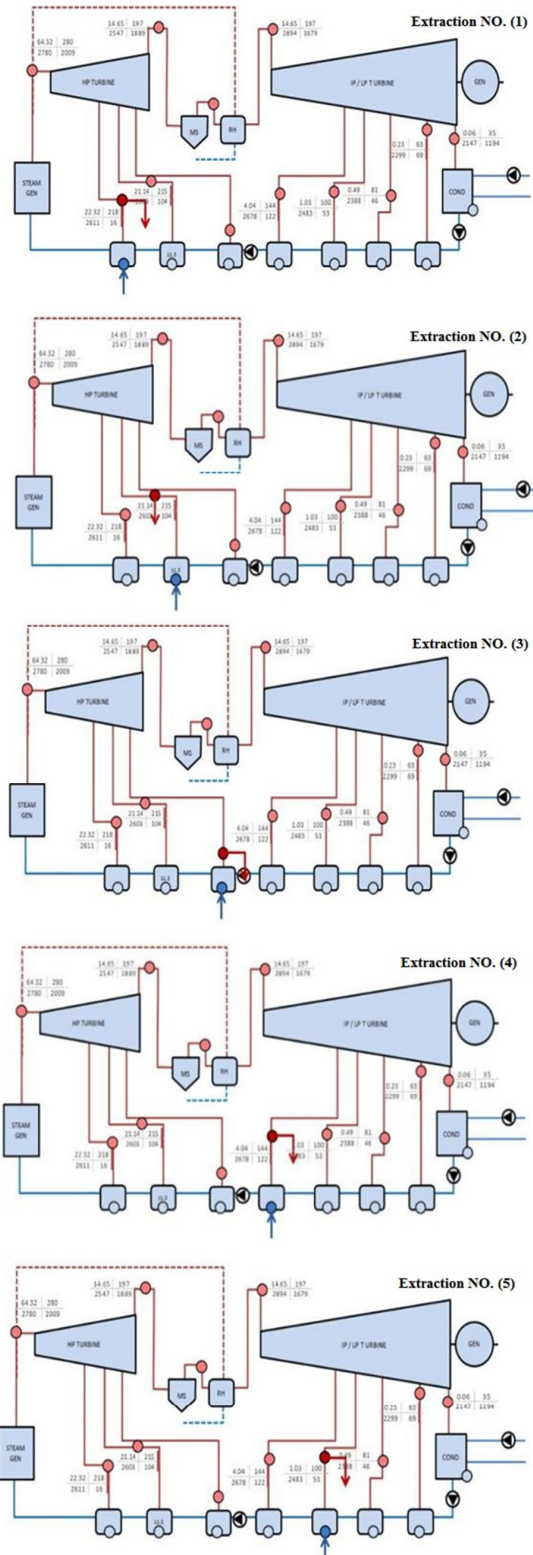

Fig. 6 Extraction points (Red arrow -down- is the extraction position, Blue arrow-up-is the return point)