

Theoretical Study on Torsional Strengthening of Multi-cell RC Box Girders

Abeer A. M., Allawi A. A., and Chai H. K.

Abstract—A new analytical method to predict the torsional capacity and behavior of R.C multi-cell box girders strengthened with carbon fiber reinforced polymer (CFRP) sheets is presented. Modification was done on the Softened Truss Model (STM) in the proposed method; the concrete torsional problem is solved by combining the equilibrium conditions, compatibility conditions and constitutive laws of materials by taking into account the confinement of concrete with CFRP sheets. A specific algorithm is developed to predict the torsional behavior of reinforced concrete multi-cell box girders with or without strengthening by CFRP sheets. Applications of the developed method as an assessment tool to strengthened multi-cell box girders with CFRP and first analytical example that demonstrate the contribution of the CFRP materials on the torsional response is also included.

Keywords—Carbon fiber reinforced polymer, Concrete torsion, Modified Softened Truss Model, Multi-Cell box girder.

I. INTRODUCTION

INTEREST in the durability of buildings is a continuous concern for the engineering environment. In this context the studies regarding the use of composite materials have appeared. FRP is one of the most applicable materials in strengthening, especially for strengthening existing structures made of reinforced concrete or masonry. One area in which FRP is being used more frequently is the strengthening of structurally deficient concrete bridges. It is to be noted that however, many concrete bridge superstructures consist of multi box cells; hence a more appropriate approach of strengthening should be developed. The indispensable need to strengthen concrete structures is on the rise. Various motivations lead to the increased demand for strengthening. Deterioration and aging of concrete structures are not the only reasons for strengthening beams. Other reasons include upgrading design standards, committing mistakes in design or construction, exposure to unpredicted loads such as truck hits or powerful earthquakes, and changing the usage of the structure.

For example, the ever-increasing truck loads are sometimes beyond the design loads of most bridges in North America that

were built after World War II. Since then, the average service loads were increased by 40 %. The strengthening should ideally minimize the amount of material added to the structure to avoid increasing the dead load or decreasing the clearance requirements. According to Meier [22], post strengthening is required when structures are subjected to loads of a greater magnitude than designed for, or in cases where design or construction errors might put their safety or performance under question. Furthermore, local strengthening may become necessary during building refurbishment processes, if there are changes in the load pattern or if some of the more exposed elements were subjected to greater deterioration than the rest of the structure. Every structure is built with a specific life span. However, despite the safety factors, structures tend to lose their structural integrity before serving their expected life. Many factors are attributed to this cause, for example, excessive loading on the structure, natural calamities, etc. Such factors weaken the structure throughout its life and in all such cases; repair and strengthening are the primary cures. Many innovative strengthening techniques as well as materials have been introduced in the past few years.

In some of the previous studies, Zojaji and M.Z. Kabir [1] developed a new computational procedure to obtain the full torsional behavior of reinforced concrete beams strengthened by FRP based on the Softened Membrane Model for Torsion (SMMT); a new model which has been recently proposed by Jeng and Hsu [2]. Based on the modified compression field theory, Deifalla and Ghobarah [3] presented a numerical simplified model for strengthening RC beams subjected to torsion. The proposed model takes into account the effect of various parameters including different failure modes. A further study by Deifalla and Ghobarah [4] resulted in proposing an analytical model capable of predicting the full torsional behavior of RC beams wrapped with FRP sheets up to failure. The model takes into account several possible strengthening techniques including continuous wrapping, spiral wrapping, one sided wrapping, and strips wrapping. The model, which was based on displacement control rather than force control, was validated using the available experimental results. Reasonably well correlations were obtained. To predict the entire behavior of the strengthened beams under torsion, Chalioris [5], [6] proposed an analytical model based on the softened truss model in combination with two other different theoretical models: the smeared crack model and modified softened truss model. Ameli et al. [7] presented the results of experiments together with a numerical study on reinforced concrete beams under pure torsion that were

Abeer A. M is with the Department of Civil Engineering, University of Baghdad, Baghdad-Iraq (phone: 0060123138047;E-mail: abaq79@yahoo.com).

Allawi A. A. is with the Department of Civil Engineering, University of Baghdad, Baghdad-Iraq (phone: 006947901879289; E-mail: abbasallawi2004@yahoo.com).

Chai H. K. Department of Civil Engineering, Faculty of Engineering Building, University of Malaya, 50603 Kuala Lumpur, Malaysia (phone: 0060379677652; E-mail: hkchai@um.edu.my).

strengthened with FRP sheets in a variety of configurations. Besides, An analytical method for evaluating the ultimate torque of FRP-strengthened reinforced concrete beams based on the compression field theory was introduced by Ameli and Ronagh [8]. Their computational procedure was however limited at predicting the torsional strength of strengthened beams and, consequently, an entire response cannot be obtained. Hii and Al-Mahaidi [9] recounted the experimental work in an overall investigation of torsional strengthening of solid and box-section reinforced concrete beams with externally bonded carbon fiber-reinforced polymer (CFRP) sheets. In their study, a database of previous experimental research findings was compiled and compared with the data by FIB Bulletin 14 [10]. Modifications consistent with the space truss model were proposed to correct the poor accuracy in predictions of CFRP contribution to strength. Subsequently, a design tool to analyze the full torsional capacity of strengthened RC beams was validated with the experimental database. Allawi A.A. [11] investigated analytically and experimentally the behavior and performance of R.C solid and hollow box member strengthened with externally bond CFRP under pure torsion; in his study analytical part was performed through developing the Softened Membrane Model to be applicable for nonlinear torsional analysis and numerical analysis was done by using DIANA software. His results provide an increase of 90% in the ultimate torsional capacity for the members strengthened with CFRP laminated.

In the present study, an analytical model to obtain the full torsional behavior of RC multi-cell box girders strengthened with CFRP based on Modified Softened Truss Model for Torsion (MSTM) will be presented. This study is an attempt to extend and modify the STM algorithm to be applicable for nonlinear torsional analysis that takes into consideration the effect of CFRP sheet confinement to concrete.

II. ANALYTICAL MODEL

The presented analytical model is based on Softened Truss Model Theory (STM). The theory was first mentioned by Hsu [13] which emphasizes the importance of incorporating of the softened constitutive laws of concrete in the analysis of RC structures. Later this method has been developed by Fu and Yang [14] to resolve torsional problem based on STM, especially for RC box girder bridge superstructures with multiple-cell sections.

All tables and figures you insert in your document are only to help you gauge the size of your paper, for the convenience of the referees, and to make it easy for you to distribute preprints.

The presented analytical model is based on Softened Truss Model Theory (STM). The theory was first mentioned by Hsu [13] which emphasizes the importance of incorporating of the softened constitutive laws of concrete in the analysis of RC structures. Later this method has been developed by Fu and Yang [14] to resolve torsional problem based on STM, especially for RC box girder bridge superstructures with multiple-cell sections.

Fig. 1 presents a strengthened RC prismatic member

subjected to an external torque T . This torque is resisted by an internal torque formed by the circulatory shear flow q along the periphery of the cross section which occupies a shear flow zone of a thickness td . After concrete member cracks, torsion is then resisted by a truss action of compressive stresses in a diagonal concrete struts, and tensile stresses in longitudinal bars, transverse stirrups, and FRP external reinforcement.

For calculating the post cracking and pre-cracking torsional behavior of multi-cell RC box girders strengthened with CFRP, the Softened Truss Model by Fu and Yang [14] for multiple box section is used. To consider the effect of CFRP strengthening, the calculation method developed by Chalioris [6] for single cell box section are adopted and modified to include the effect of strengthening for multi cell box girders.

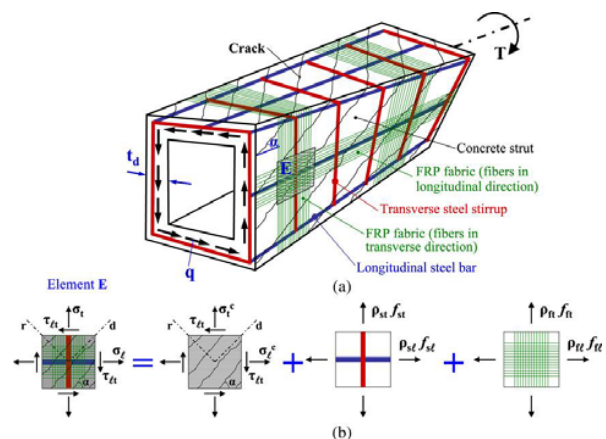

Fig. 1 Space truss for the torsional analysis of R.C. beam strengthened with FRP composites [6]

In this proposed method, the equilibrium and compatibility equations are solved in combination with the constitutive laws of an element for a member subjected to pure torsion, as shown in Fig. 1. A procedure steps developed to establish the torque-twist curve.

A. Equations for Multiple Cells

Assume a structural section with N cells, Fig. 2. According to restraint condition $\theta = \theta_1 = \theta_2 = \dots = \theta_N$, a set of simultaneous equations for cell i can be obtained [12].

B. Equilibrium Equations

A R.C. element, as shown in Fig. 1(a), is reinforced orthogonally with longitudinal and steel reinforcements. The applied stresses on the element have three stress components, and the longitudinal steels are arranged in the l direction (horizontal axis) with a uniform spacing of s_l . The transverse steels are arranged in the t direction (vertical axis) with a uniform spacing of S . In this study, the effect of FRP forces is included in equilibrium equations by considering CFRP sheets as additional external reinforcements. After cracking, the concrete is separated by diagonal cracks into a series of concrete struts, as shown in Fig. 1(b). The cracks are oriented at an angle α with respect to the l -axis. The principal stresses on the concrete strut itself are denoted as σ_α and σ_γ .

According to the unified theory, after transformation, the governing equations for equilibrium condition are shown as follows [15]:

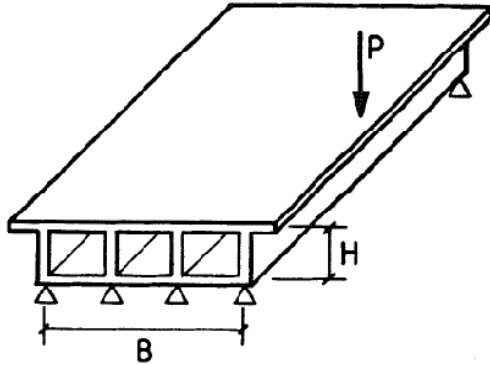

Fig. 2 Multi-cell box girder under torsion [21]

$$\sigma_l = \sigma_d \cos^2 \alpha + \sigma_r \sin^2 \alpha + \rho_{ls} f_{ls} + \rho_{lf} f_{lf} \quad (1)$$

$$\sigma_t = \sigma_d \cos^2 \alpha + \sigma_r \sin^2 \alpha + \rho_{ts} f_{ts} + \rho_{tf} f_{tf} \quad (2)$$

$$\tau_{lt} = (-\sigma_d + \sigma_r) \sin \alpha \cos \alpha \quad (3)$$

$$T = \tau_{lt} (2A_o t_d) \quad (4)$$

where σ_l, σ_t , and τ_{lt} are the three stress components of the composite element Fig. 1(a); σ_d, σ_r are the concrete stresses in d - and r -directions, respectively Fig. 1(b); α is the angle between l and d axes; f_{ls}, f_{ts} are the stresses in steel in the l - and t -directions, respectively; f_{lf}, f_{tf} are the stresses in CFRP in the l - and t -directions, respectively; ρ_{ls} and ρ_{ts} are steel ratios in the l - and t -directions, respectively; ρ_{lf}, ρ_{tf} are CFRP ratio in the l - and t -directions, respectively; T is the external torque; A_o is cross sectional area bounded by the center line of the shear flow zone; and t_d is shear flow zone thickness. It should be noted that, for a multiple-cell box section under pure torsion, $\sigma_l = \sigma_t = \sigma_r = 0$ and, assuming a structural section has N cells, a set of simultaneous equations for cell i can always be obtained:

$$\tau_{lti} = (-\sigma_{di}) \sin \alpha_i \cos \alpha_i \quad (5)$$

$$T_i = \tau_{lti} (2A_{oi} t_{di}) \quad (6)$$

C. Compatibility Equations

Similarly, the governing equations for compatibility condition based on the unified theory are shown as follows:

$$\varepsilon_{li} = \varepsilon_{di} \cos^2 \alpha_i + \varepsilon_{ri} \sin^2 \alpha_i \quad (7)$$

$$\varepsilon_{ti} = \varepsilon_{di} \cos^2 \alpha_i + \varepsilon_{ri} \sin^2 \alpha_i \quad (8)$$

$$\frac{\gamma_{lti}}{2} = (-\varepsilon_{di} + \varepsilon_{ri}) \sin \alpha_i \cos \alpha_i \quad (9)$$

$$\theta = \theta_i = \frac{P_{oi}}{2A_{oi} \gamma_{lti}} \quad (10)$$

$$\psi_i = \theta \sin 2\alpha_i \quad (11)$$

$$t_{di} = \frac{\varepsilon_{dsi}}{\psi_i} \quad (12)$$

$$\varepsilon_{di} = \frac{-\varepsilon_{dsi}}{2} \quad (13)$$

where $\varepsilon_{li}, \varepsilon_{ti}$, and γ_{lti} are the three strain components in the l, t -coordinate for ; ε_{di} and ε_{ri} are strains in the d and r directions, respectively; θ = angle of twist of a member; P_{oi} is the perimeter of the center line of shear flow zone; ψ_i is the bending curvature of concrete struts; and ε_{dsi} is the maximum strain of concrete struts for each cell i .

D. Constitutive Relationships of Materials

The stress–strain relationship used in the proposed model is that developed by Belarbi and Hsu [16] for a softened compressive concrete, which was then modified by Chalioris [6] to include the effect of FRP confinement by using the parameters proposed by Vinzileou and Panagiotidou [17]. The proposed stress–strain relationship is defined as a parabolic equation until the point of ultimate stress, and after that point the curve is linearly reduced until the point of ultimate strain ε_{cu} as follows (see also Fig. 3(a)).

$$K_{1i} = \frac{\varepsilon_{di}}{\varepsilon_{pi}} \quad (14)$$

$$\sigma_{di} = \sigma_{pi} \left[2 \frac{\varepsilon_{di}}{\varepsilon_{pi}} - \left(\frac{\varepsilon_{di}}{\varepsilon_{pi}} \right)^2 \right] \text{ for } \frac{\varepsilon_{di}}{\varepsilon_{pi}} \leq 1 \quad \text{or,} \quad (15)$$

$$\sigma_{di} = \sigma_{pi} \frac{\varepsilon_{di}}{\varepsilon_{pi}} \quad \text{for } \frac{\varepsilon_{di}}{\varepsilon_{pi}} > 1$$

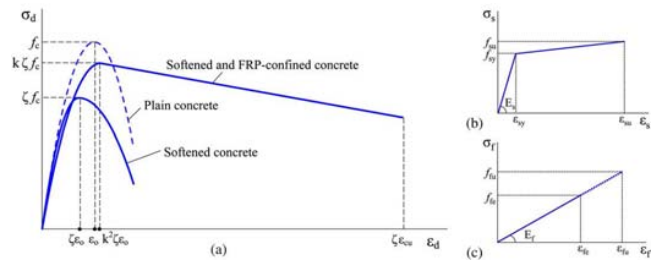

Fig. 3 Constitutive stress–strain laws for the materials: (a): concrete; (b): steel; (c): FRP [6]

$$\sigma_{pi} = k \zeta_i f'_c \quad (16)$$

$$\varepsilon_{pi} = k^2 \zeta_i \varepsilon_o \quad (17)$$

where f'_c is the concrete cylinder compressive strength, ε_o is the concrete strain at the peak compressive stress taken as -0.002 , ζ is the softening coefficient calculated from Eq. (18), and k is the CFRP-confinement parameter, which is obtained from a simple empirical equation taken as Eq. (22):

$$\zeta_i = \frac{0.9}{\sqrt{1+400 \varepsilon_{ri}}} \quad (18)$$

The stress-strain relationship for steel bars, which is used in STM for both directions, is as follows:

$$f_{si} = E_s \varepsilon_{si} \quad \text{for} \quad \varepsilon_{si} \leq \varepsilon_n \quad (19)$$

$$f_{si} = f_y \left[(0.9 - 2B) + (0.02 + 0.25B) \frac{\varepsilon_{si}}{\varepsilon_y} \right] \quad \text{for} \quad \varepsilon_s > \varepsilon_n \quad (20)$$

where:

$$B = \frac{\left(\frac{f_{cr}}{f_y}\right)^{1.5}}{\rho} \quad \text{and} \quad \varepsilon_n = \varepsilon_y(0.93 - 2B) \quad (21)$$

The confinement parameters k of an empirical model for FRP-confined concrete which was proposed by Vinzileou and Panagiotidou [17], was considered:

$$k = 1 + 2.8 * 0.5 \alpha_n \omega_n \quad (22)$$

$$\alpha_n = 1 - \frac{b^2 + h^2}{3 A_c} \quad (23)$$

where α_n is the in-section coefficient confinement calculated by the cross-section dimensions b and h . The parameter ω_w denotes the volumetric mechanical ratio for external FRP-confinement, taken as:

$$\omega_w = \frac{\text{Volume of FRP material}}{\text{Volume of the confined concrete core}} \frac{f_{fu}}{f'_c} \quad (24)$$

where f_{fu} is the ultimate tensile strength of the FRP.

The stress-strain relationships shown in Fig. 1(b) and c are used for the steel reinforcement and the FRP materials, respectively.

For the CFRP, the effective strain in the principal material direction ε_{fe} is estimated using the following analytical approaches.

For the case of CFRP, the model of Triantafillou and Antonopoulos [18], which has been adopted in FIB Bulletin 14 [10], is considered:

For wrapping and rupture failure:

$$\varepsilon_{fe} = 0.17 \left(\frac{f'_c}{E_f \rho_f} \right)^{0.30} \varepsilon_{fu} \quad (25)$$

where E_f is the elastic modulus of the FRP. The effective stress of the FRP is calculated by Hooke's law and the modulus of elasticity (Fig. 3 (c)):

$$f_{fe} = \varepsilon_{fe} E_f \quad (26)$$

The thickness of shear flow zone t_{di} can be expressed in terms of strains using the compatibility equations and in terms of A_o and P_o as below:

$$t_{di} = \frac{A_{oi}}{P_{oi}} \left[\frac{(-\varepsilon_{di})(\varepsilon_{ri} - \varepsilon_{di})}{(\varepsilon_{li} - \varepsilon_{di})(\varepsilon_{ti} - \varepsilon_{di})} \right] \quad (27)$$

The strain ε_{li} can be related to the stress f_{li} by eliminating the angle α from the equilibrium equation (1)

$$\varepsilon_{li} = \varepsilon_{di} + \frac{A_{oi}(\varepsilon_{di})(-\sigma_{di})}{A_{li}f_{li} + A_{tj}f_{tj}} \quad (28)$$

Similarly, the strain ε_{ti} can be related to the stress f_{ti} by eliminating the angle α from equilibrium equation (2)

$$\varepsilon_{ti} = \varepsilon_{di} + \frac{A_{oi}(\varepsilon_{di})(-\sigma_{di})}{P_{oi}(A_{ti}f_{ti} + A_{tj}f_{tj})} \quad (29)$$

Also, A_{oi} and P_{oi} can be expressed as functions of t_{di} :

$$A_{oi} = A_{ci} - \frac{1}{2} P_{oi} t_{di} + t_{di}^2 \quad (30)$$

$$P_{oi} = P_{ci} - 4t_{di} \quad (31)$$

where A_{ci} is the cross-sectional area of the i th cell bounded by the outer perimeter of the FRP; P_{ci} is the perimeter of the i th cell outer FRP. The values of ε_{ri} and ψ can be expressed in terms of strains ε_{li} , ε_{ti} , and ε_{di} by

$$\varepsilon_{ri} = \varepsilon_{li} + \varepsilon_{ti} - \varepsilon_{di} \quad (32)$$

$$\tan^2 \alpha_i = \frac{\varepsilon_{li} - \varepsilon_{di}}{\varepsilon_{ti} - \varepsilon_{di}} \quad (33)$$

From (9) to (11) an additional equation is obtained:

$$\varepsilon_{di} = -\frac{1}{2} t_{di} \theta \sin 2\alpha_i \quad (34)$$

E. Solution Procedure

A solution procedure has been proposed, which facilitates torsional analysis by following the procedures presented in appendix I. A computer program has been written to analyze the torsional behavior of RC multi cell box girders strengthened with CFRP.

F. FIB Bulletin 14

In order to validate the proposed analytical method, results are compared with data computed using method specified in FIB Bulletin 14 [10]. The bulletin states that an externally bonded FRP jacket will provide contribution to the torsional capacity only if full wrapping around the element's cross section is applied, so that the tensile forces carried by the FRP on each side of the cross section may form a continuous loop. Based on the assumption of the validity of the truss mechanism, the following equations were provided to predict the FRP contribution to strength $T_{n, FRP}$:

$$T_{n,FRP} = 2 \epsilon_{fd,e} E_{fu} A_f S_f^{-1} A_c (\cot \theta + \tan \alpha) \sin \alpha \quad (35)$$

$$\epsilon_{f,cal} = T_{f,exp} / [2 E_{fu} A_f S_f^{-1} A_c (\cot \theta + \tan \alpha) \sin \alpha] \quad (36)$$

$$\epsilon_{fk,e} = k \epsilon_{fe} \leq \epsilon_{max} \quad (37)$$

$$\epsilon_{fd,e} = \epsilon_{fk,e} / \gamma_f \quad (38)$$

where A_f is the area of fiber strip/wrap $b_f t_f$; b_f is the width of FRP strips; k is used to define the characteristic effective FRP strain, $\epsilon_{fk,e}$; S_f is the center-to-center spacing of FRP strips; t_f is thickness of fiber laminate; θ is angle between the principal fiber orientation and the longitudinal axis of member; $\epsilon_{fd,e}$ is design value of effective fiber strain; ϵ_{max} =5,000 micro strain for activation of the aggregate interlock mechanism; γ_f is material safety factor for the FRP range (1.2–1.5) specified in the Bulletin; and α is the angle of crack to the longitudinal axis.

The full torsional strength of CFRP-strengthened RC beams can be analyzed by the design codes using the principle of superposition from both the steel and CFRP reinforcement. The proposed general form is shown in Eq. (39) [19]

$$T_{n,nFRP} = T_{n,s} + T_{n,FRP} \quad (39)$$

where T_n is, the nominal torsional capacity of the FRP strengthened beam; $T_{n,s}$ is the nominal torsional capacity from steel reinforcement; and $T_{n,FRP}$ is the nominal torsional capacity from FRP reinforcement.

According to American Concrete Institute Code ACI Committee ACI-318 (2008) [20], the nominal torsional capacity of steel reinforcement can be obtained from the following formula:

$$T_{n,s} = 2 \frac{A_o A_{st} f_y}{S} \cot \alpha \quad (40)$$

where A_o is, the perimeter of the shear flow zone, A_{st} is the reinforcement area of the enclosed stirrups, S is the spacing of the steel stirrups and f_y is the yield strength of the steel reinforcement.

III. MODEL VALIDATION

The prediction of the entire torsional behavior of RC multi-cell box girder strengthened with CFRP is initially based on a combined analytical procedure that has already been used for R.C. beams [6]. In the present study this approach is extended to include the influence of epoxy bonded FRP materials on the torsional response. The method employs the combination of two different theoretical models. In appendix 1 an analytical procedure is presented to predict the full torsional behavior for double cell box girders with/without CFRP. By application of this procedure on example in appendix 2, for each ϵ_{di} a value for T and θ can be obtained to draw the $T - \theta$ curve in order to obtain the maximum torsional capacity of the double cell box girder strengthened with CFRP $T_{MSTM} = 74.56$ KN.m as shown in Fig. 4.

According to FIB Bulletin 14 method [10], the maximum torsional capacity, $T_{FIB} = 79.08$ KN.m. Fig. 4, also shows the increasing of torsion capacity of the member strengthened with CFRP, the increment percentage reached 75.77%.

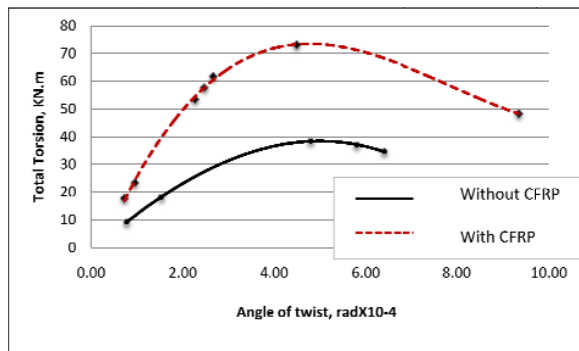

Fig. 4 Torsion versus Angle of Twist

The table below will present the increasing percentage for the maximum torsional capacity for single and double cell box girders of same example in appendix 1 by the application of two methods.

TABLE I
MAXIMUM TORSION CAPACITY AND INCREASING PERCENTAGE DUE TO CFRP

No. of Cell	$T_{n,s}$ Present study KN.m (1)	$T_{n,s,nFRP}$ Present Study KN.m (2)	$T_{n,s,nFRP}$ FIB 14 KN.m (3)	% increase using CFRP (1)/(2)	% difference two methods (2)/(3)
1	19.02	35.01	38.11	54.32	8.1
2	56.50	74.56	79.08	75.77	5.7

IV. CONCLUSION

The existing theory of MSTM is extended and modified to be applicable for nonlinear torsional analysis of reinforced concrete multi-cell box girders. Additional compatibility equations have been introduced to incorporate the effect of CFRP laminates. The exerted confinement employs the contribution of the externally bonded CFRP to the torsional capacity. Application of this methodology allows for a realistic modelling of the elastic and the post-cracking

response of FRP strengthened RC beams under torsion. According to comparison of results for MSTM method with that obtained using the FIB Bulletin 14 [10], the following conclusions are made:

- 1) The suggested algorithm for solving the related equations for torsional analysis of the strengthened girders is particularly suitable for practical applications.
- 2) The Modified Softened Truss Model theory can confidently predict the torsional behavior (torque-twist) history including both the pre-peak and post-peak behavior.
- 3) The MSTM theory is able not only to predict the torsional strength of a member, but can also predict the shear deformation, angle of twist, and stresses in concrete, steel and CFRP through the post-cracking stage of behavior.
- 4) The only torsional design method for reinforced concrete members strengthened with CFRP recommended by FIB Bullutein14 [10] was found to be generally unconservative, the staggering concept of torsion design may be conservative and underestimates the torsion capacity, which is very suitable for analytical problems.
- 5) The strengthening method by using CFRP increases the maximum torsion capacity by 54.4%, 75.77% for single, and double cell box girder respectively.
- 6) Further refinement is needed for FIB Bulltein14 guidelines to make it suitable as a design method for torsional strengthening.

APPENDIX I

Steps for solution procedure:

- 1) Input number of cells, $i=1, 2, 3 \dots N$.
- 2) Input area of steel in the longitudinal and transverse direction for each cell, i .
- 3) Assume initial strain in d and r directions and the thickness of shear flow for each cell, i ($\epsilon_{di}, \epsilon_{ri}, t_{di}$).
- 4) Calculate A_{oi} and P_{oi} for each cell, i .
- 5) Calculate ζ_i, k_{1i} and σ_{di} for each cell i , equations (18), (14) and (15).
- 6) Solve for ϵ_{li} for f_{li} and ϵ_{ti} for f_{ti} , equations (28) and (29).
- 7) Calculate ϵ_{ri}, t_{di} , equations (32) and (27).
- 8) If the calculated ϵ_{ri} close to the assumed ϵ_{ri} then calculate $\alpha_i, \tau_{lti}, T_i, \gamma_{lti}$ for each cell, i , equations (33), (5), (6) and (9). Then calculate θ_i, ψ_i , equations (10) and (11). If not then assume another value of ϵ_{ri} and repeat steps 3 to 7.
- 9) After calculating θ_i for each cell i ; if $\theta_1 = \theta_2 = \dots = \theta_N$ then calculate ϵ_{di} , equation (34).
- 10) Repeat steps 1 to 9 for other values of θ_i and T_i .
- 11) Calculate the total torsion, T , equation (39).

APPENDIX II

Example: Analyze the torque-twist behavior of the hollow double-cell box girder with rectangular cross sections as shown in Fig. 3. the girder is reinforced with 3- ϕ 12 longitudinal bars in the top and bottom directions and ϕ 6

transverse hoop bars at 50 mm spacing. Both sizes of mild steel bars have yield strength of 420 Mpa. It is also strengthened with CFRP strips transversely spaced 50 mm centre to centre, the width of each strip is 50 mm and the thickness of the strip is 0.142 mm. The ultimate tensile strength of the CFRP is 4900 Mpa. The decompression strain is 0.005. The cylinder compressive strength of concrete is 30 Mpa. The tensile strength of concrete is neglected ($\sigma_r = 0$) and the concrete cover is 20 mm.

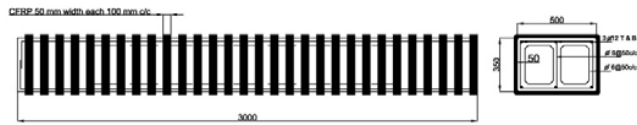

Fig. 5 Analysis example of double-cell box girder (dimensions in mm)

Solution:

- 1) Number of cells=2
- 2) Assume ϵ_{di} for each cell i , $\epsilon_{d1} = \epsilon_{d2} = -0.00015$
- 3) Properties of concrete, $w=500$ mm, $h=350$ mm, $t=50$ mm, $\epsilon_o = -0.002$, $f'_c = 30$ Mpa, $L=3000$ mm, $E_s = 200000$ Mpa, $s=50$ mm, $f_y = 420$ Mpa, $f_{su} = 620$ Mpa, $\epsilon_{su} = 0.3$.
- 4) Properties of CFRP, $t_f = 0.142$ mm, $w_f = 50$ mm, $s_f = 50$ mm $\epsilon_{fu} = 0.021$, $f_{fu} = 4900$ Mpa, $E_f = 230000$ Mpa, $\epsilon_{ef} = 0.004$, $n_f = \frac{L}{w_f}$.
- 5) Area of fiber, $A_{ft} = w_f * t_f$; $A_{ft} = 2*0.142 = 0.284$ mm²
- 6) Perimeter of fiber for each cell, $p_{ft1} = p_{ft2} = 2 * w + h = 1350$ mm
- 7) Area of concrete, $A_c = (w * h) - ((w - 2 * t) * (h - 2 * t)) = 75,000$ mm² $\epsilon_{ri} = \epsilon_{li} + \epsilon_{ti} - \epsilon_{di}$, $\epsilon_{r1} = \epsilon_{r2} = 0.0092$
- 8) Volume of CFRP and confined concrete, $V_{fi} = p_{fti} * t_f * w_f * n_f$, $V_{cc} = A_c * w_f * n_f$, $w_{wi} = V_{fi} * \frac{f_{fu}}{V_{cc} * (-f'_c)}$, $\alpha_n = 1 - (\frac{w^2 + h^2}{3 A_c})$, $k_i = 1 + 2.8 \alpha_n w_{wi}$, $\epsilon_{cui} = 0.003 * k_i^2$

Then,

$$V_{f1} = V_{f2} = 0.374 \text{mm}^3,$$

$$V_{cc} = 225 * 10^6 \text{mm}^3,$$

$$w_{w1} = w_{w2} = 0.3644$$

$$k_1 = k_2 = 0.811$$

$$\epsilon_{cu1} = \epsilon_{cu2} = 0.0023$$

$$A_{st1} = A_{st2} = 635.5 \text{mm}^2,$$

$$A_{st1} = A_{st2} = 29 \text{mm}^2,$$

Assume ε_{ri}, t_{di} for each cell $i, \varepsilon_{ri} = 0.015, t_{di} = 50 \text{ mm}$.

- 9) Calculate the area and perimeter of concrete for reach cell i ,

$$A_{oi} = w * h,$$

$$p_{oi} = 2 * (w + h)$$

So, $A_{c1} = A_{c2} = 175,000 \text{ mm}^2$

$$p_{c1} = p_{c2} = 1,700 \text{ mm}$$

Then,

$$A_{oi} = A_{ci} - \left(\frac{p_{ci} * t_{di}}{2} + t_{di}^2 \right),$$

$$p_{oi} = p_c - 4 t_{di}$$

$$\rho_{fti} = A_{ft} * \frac{p_{fti}}{p_{oi} * t_{di} * s_f},$$

$$\varepsilon_{fei} = 0.17 * \left(\frac{(-f'_c)^{2/3}}{E_f * \rho_{fti}} \right)^{0.3} * \varepsilon_{fu}$$

So, $A_{o1} = A_{o2} = 68,536 \text{ mm}^2$

$$p_{o1} = p_{o2} = 1,066.2 \text{ mm}$$

$$\rho_{ft1} = \rho_{ft2} = 0.0014$$

$$\varepsilon_{fe1} = \varepsilon_{fe2} = 6.8441 * 10^{-4}$$

- 10) Calculate the stress in concrete for each cell i ,

$$\zeta_i = \frac{0.9}{\sqrt{1+400 \varepsilon_{ri}}}, \zeta_1 = \zeta_2 = 0.340$$

$$\varepsilon_{dsi} = \varepsilon_{di} * 2, \varepsilon_{ds1} = \varepsilon_{ds2} = -3 * 10^{-4}$$

$$\varepsilon_{pi} = k_i^2 * \zeta_i * \varepsilon_o, \varepsilon_{p1} = \varepsilon_{p2} = -6.4555 * 10^{-4}$$

$$r_i = \varepsilon_{dsi} / \varepsilon_{pi}, r_1 = 4.3374, r_2 = 3.6411$$

r_1 and $r_2 > 1$ then,

$$k_{11} = k_{12} = 1$$

$$\sigma_{di} = k_{1i} * \zeta_i * f'_c, \text{ then, } \sigma_{d1} = \sigma_{d2} = -13.30 \text{ Mpa}$$

- 11) Calculate the strain in the longitudinal and transverse directions respectively accordingly,

$$\varepsilon_{li} = \varepsilon_{di} + \frac{A_{oi}(\varepsilon_{di})(-\sigma_{di})}{A_{lifu} + A_{tifu} f_{ti}} \quad \text{And} \quad \varepsilon_{ti} = \varepsilon_{di} +$$

$$\frac{A_{oi} s(\varepsilon_{di})(-\sigma_{di})}{p_{oi}(A_{tifu} + A_{tifu} f_{ti})}, \text{ then}$$

$$\varepsilon_{l1} = 3.9 * 10^{-3}, \varepsilon_{l2} = 2.1 * 10^{-3}$$

$$\varepsilon_{t1} = 3.9 * 10^{-3}, \varepsilon_{t2} = 2.1 * 10^{-3}$$

$$\varepsilon_{ri} = \varepsilon_{li} + \varepsilon_{ti} - \varepsilon_{di}$$

$$\varepsilon_{r1} = \varepsilon_{r2} = 0.0092$$

- 12) Calculate the effective thickness,

$$t_{di} = \frac{A_{oi}}{p_{oi}} \left[\frac{(-\varepsilon_{di})(\varepsilon_{ri} - \varepsilon_{di})}{\ln(\varepsilon_{li} - \varepsilon_{di})(\varepsilon_{ti} - \varepsilon_{di})} \right]$$

$$t_{d1} = t_{d2} = 34 \text{ mm}$$

13- If $\theta_1 = \theta_2$ then $\alpha_i, \tau_{lti}, T_i, \gamma_{lti}, \psi_i$ and T , can be obtained

$$\theta_1 = \theta_2 = 6.187 * 10^4 \text{ rad}$$

Then,

$$\alpha_1 = \alpha_2 = 0.768$$

$$\tau_{lt1} = 6.65 \text{ Mpa, and } \tau_{lt2} = 8.0 \text{ Mpa}$$

$$T_1 = 37.28 \text{ KN.m, and } T_2 = 37.28 \text{ KN.m}$$

$$\gamma_{lt1} = 0.003, \text{ and } \gamma_{lt2} = 0.003$$

$$\psi_1 = \psi_2 = 5.8462 * 10^4$$

$$T = 74.56 \text{ KN.m}$$

NOTE

The present article is a part of PhD study for the author Abeer A. M in University of Baghdad, College of Engineering, civil department, structures 2013.

REFERENCES

- [1] A.R. Zojaji, M.Z. Kabir "Analytical approach for predicting full torsional behavior of reinforced concrete beams strengthened with FRP materials" Scientia Iranica, Transactions A: Civil Engineering 19, pp. 51-63(2012).
- [2] Jeng, C.H. and Hsu, T.T.C. "A softened membrane model for torsion in reinforced concrete members", Engineering Structures, 31(9), pp. 1944-1954 (2009).
- [3] Deifala, A.F. and Ghobarah, A. "Simplified analysis for torsionally strengthened RC beams using FRP", in: Proceeding of the International Symposium on Bond Behavior of FRP in Structures, BBFS 2005, International Institute for FRP in construction (2005).
- [4] Deifala, A.F. and Ghobarah, A. "Full torsional behavior of RC beams wrapped with FRP: analytical model", Composites for Construction, 14(3), pp. 289-300 (2010).
- [5] Chalioris, C. "Torsional strengthening of rectangular and flanged beams using carbon fibre reinforced-polymers—experimental study", Construction & Building Materials, 22(1), pp. 21-29 (2008).
- [6] Chalioris, C. "Analytical model for torsional behavior of reinforced concrete beams retrofitted with FRP materials", Engineering Structures, 29(12), pp. 3263-3276 (2007).
- [7] Ameli, M., Ronagh, H.R. and Dux, P.F. "Behavior of FRP strengthened reinforced concrete beams under torsion", Composites for Construction, 11(2), pp. 192-200 (2007).
- [8] Ameli, M. and Ronagh, H.R. "Analytical method for evaluating ultimate torque of FRP strengthened reinforced concrete beams", Composites for Construction, 11(4), pp. 384-390 (2007).
- [9] Hii, A.K.Y. and Al-Mahaidi, R. "An experimental and numerical investigation on torsional strengthening of solid and box-section RC beams using CFRP laminates", Composite Structures, 75, pp. 213-221 (2006).
- [10] FIB, "Externally bonded FRP reinforcement for RC structures", CEB-FIP, Technical Report, 14, pp. 59-68 (2001).
- [11] Allawi A. A. "Nonlinear Analysis Of Reinforced Concrete Beams Strengthened By Cfpr In Torsion" PhD thesis, University of Baghdad, College of Engineering, Civil Engineering Department, 2006.
- [12] Chung C. Fu and Daili Yang, "Designs of Concrete Bridges with Multiple Box Cells Due to Torsion Using Softened Truss Model", ACI Structural Journal, Technical Paper, Vol.94, No.6, Nov-Dec, pp 696-702.
- [13] Hsu, T. T. C., (1988) "Softening Truss Model Theory for Shear and Torsion," ACI Structural Journal, Vol. 85, No. 6, Nov.-Dec., pp. 624-635.
- [14] Chung C. Fu and Daili Yang, "Torsional Analysis for Prestressed Concrete Multiple Cell Box", Journal of Engineering Mechanics, Vol. 127, No. 1, January, 2001.
- [15] Hsu, T. T. C., (1993) *Unified Theory of Reinforced Concrete*, CRC Press, Inc., Florida.
- [16] Belarbi, A. and Hsu, T.T.C. "Constitutive laws of softened concrete in biaxial tension-compression", ACI Structural Journal, 92(5), pp. 562-573 (1995).
- [17] Vintzileou, E. and Panagiotidou, E. "An empirical model for predicting the mechanical properties of FRP-confined concrete", Construction & Building Materials, 22(8), pp. 841-854 (2008).
- [18] Triantafyllou TC, Antonopoulos CP. "Design of concrete flexural members strengthened in shear with FRP". Journal of Composites for Construction 2000;4(4):198-205.
- [19] Adrian K. Y. Hii and Riadh Al-Mahaidi, "Torsional Capacity of CFRP Strengthened Reinforced Concrete Beams". Journal of Composites for Construction, January-February 2007.
- [20] ACI 318-08: Building Code Requirements for Structural Concrete (318-08) and Commentary (318R-08). American Concrete Institute, Farmington Hills, MI., 391 pages, 2008.

- [21] Sible F., Alex C. Scordelis “Nonlinear Behaviour and Failure Analysis of Multicell Reinforced Concrete Box Girder Bridges” Canadian Journal for Civil Engineering, Vol. 11, 1984.
- [22] Meier U (1995) ‘Strengthening of structures using carbon fibre/epoxy composites’, *Construct Build Mater* **9**(6) 341–351.