

The Influence of Voltage Flicker for the Wind Generator upon Distribution System

Jin-Lung Guan, Jyh-Cherng Gu, Ming-Ta Yang, Hsin-Hung Chang, Chun-Wei Huang, and Shao-Yu Huang

Abstract—One of the most important power quality issues is voltage flicker. Nowadays this issue also impacts the power system all over the world. The fact of the matter is that the more and the larger capacity of wind generator has been installed. Under unstable wind power situation, the variation of output current and voltage have caused trouble to voltage flicker. Hence, the major purpose of this study is to analyze the impact of wind generator on voltage flicker of power system. First of all, digital simulation and analysis are carried out based on wind generator operating under various system short circuit capacity, impedance angle, loading, and power factor of load. The simulation results have been confirmed by field measurements.

Keywords—Wind Generator, Voltage Flicker, ΔV_{10} Value.

I. INTRODUCTION

SINCE the Industrial Revolution in the 18th century, humans have replaced traditional manpower production with machine production, and the demand for various energy sources has increased greatly. As populations increase and the economies develop, global oil reserves will be exhausted in about 50 years at the present consumption rate, and natural gas may be available for about 70 more years. Coal will last longer; however, it can only be used for about 200 more years. Therefore, besides increasing the service efficiency of energy, looking for new renewable energy sources has become an urgent topic.

Renewable energy can make up for the insufficiency of energy, as well as slow down environmental pollution. Power generation modes include wind power, water power, solar energy, geothermal heat, methane, tidal and biomass energy. Among these, wind power generation has become technically mature; therefore, wind power generation is the most promising renewable energy source presently being developed.

Taiwan is an island with a monsoon period that lasts more than half of each year. The annual average wind speed in many coastal, mountainous and off-island areas is higher than 4m per second; therefore, the wind energy potential is outstanding. According to investigation, the total area of the regions in Taiwan where the annual average wind speed is higher than 4m per second is about 2,000 square kilometers, and the exploitable wind energy potential is estimated at about 3,000 MW.

J. L. Guan and H. H. Chang are with the Department of Electrical Engineering, Hwa Hsia Institute of Technology, Taipei, Taiwan, R.O.C. (e-mail: gjl4127@cc.hwh.edu.tw)

J. C. Gu, C. W. Huang, and S. Y. Huang are with the National Taiwan University of Science and Technology, Taipei, Taiwan, R.O.C. (e-mail: jcg@mouse.ee.ntust.edu.tw)

M. T. Yang is with the St. John's University of Science and Technology, Taipei, Taiwan, R.O.C. (e-mail: mtyang@mail.sju.edu.tw)

Therefore, the mid-west seashore and off-island regions in Taiwan are suitable for wind power generation.

The main reason for voltage flicker is the fast changing load in the power system. However, as the quantity and installed capacity of wind generators increases, the output voltage and output current of wind generators may vary with the wind speed, and the variations in the output voltage may cause voltage flicker.

Voltage flicker will affect the luminance of daylight lamps and filament lamps, causing eye discomfort. Long-term continuous flickering will tire the eyes, therefore [1], [2] the most important concern about voltage flicker is its influence on vision. In addition, video size also varies with voltage flicker, and as television screens have white points or white lines, different sophisticated electronics may be influenced by different degrees [3]. In order to know the effect of wind generators on voltage flicker, IEC61400-21 [4] and IEEE 1547 [5] show detailed specifications and restrictions.

Taiwan does not have complete specifications for voltage flicker; however, the "Rule of Indoor Wiring Installation" has related regulations. Article 431 specifies that "the voltage flicker value ΔV_{10} of sudden changing loads such as arc furnaces at common points shall not exceed 0.45%".

The effect of voltage flicker resulting from unstable wind speed becomes severe as the quantity and installed capacity of wind generators increases. In addition, according to actual measurements, the amount voltage flicker varies with the short-circuit capacity, system impedance angle and the quantity of the wind generators. Therefore, this paper studied the influence of wind generators on voltage flicker in the power system, using actual measurements and simulations to discuss the relation of contact capacity, system impedance angle, capacity, and load power factors to voltage flicker when the generators run at different wind speeds.

II. ANALYSIS OF THE MEASURED DATA OF WIND FIELD VOLTAGE FLICKER

Two commercialized wind fields in Taiwan, represented as A and B were measured. The wind generating set of field A consisted of six generators with a rated capacity of 660 kW, connected to the power grid through a dedicated line. The wind-generating set of field B consisted of two generators with a rated capacity of 1.75 MW for in-plant power supply. The measurement duration was seven days, and the measuring points included the high and low voltage sides of the generators, the point of common coupling (PCC) and the secondary side of the main transformer. The basic data and

system one-line diagrams of the wind fields are shown in Table I, Figs. 1 and 2.

TABLE I
THE BASIC DATA OF THE WIND FIELDS

Name of wind field	Voltage level	Wind generating set	Measurement duration
Field A	11.4kV	induction generators	8/24 ~ 8/30
Field B	11.4kV	two double-fed induction generators	8/31 ~ 9/7

TABLE II
THE ANALYSIS TIME OF THE WIND FIELDS

Measuring point	Time interval	Sampling time	Average active power of wind field
Field A	a	8/26 00:10-01:20	296 kW
	b	8/28 18:25-22:25	193 kW
Field B	a	8/31 17:30-20:20	3330 kW
	b	9/4 10:00-18:00	985 kW

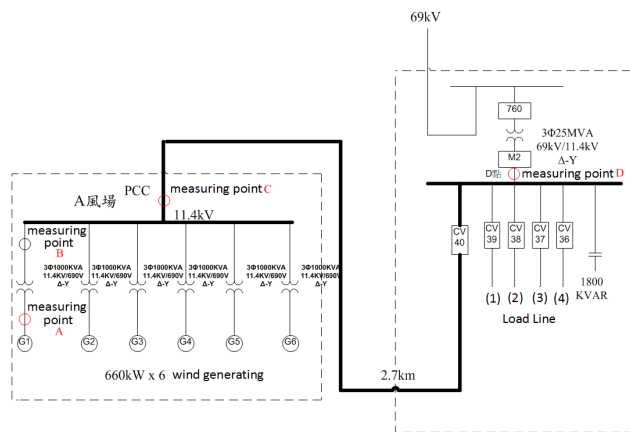

Fig. 1 One-line diagrams of the A wind field

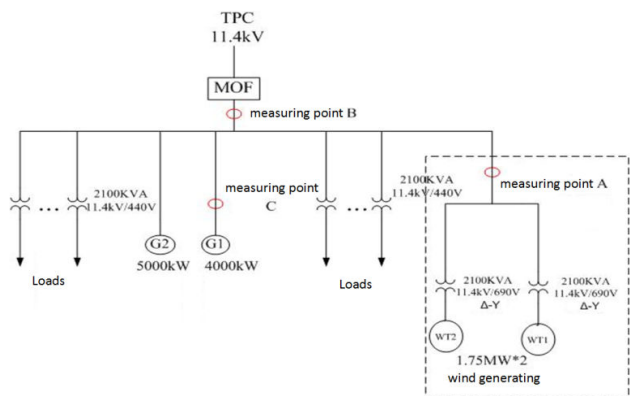

Fig. 2 One-line diagrams of the B wind field

As for the selection of measured data, as wind power resources are unstable, this paper selected the data from running generators for analysis. The analysis time is shown in Table II. Although the electrical characteristics of wind generators have no normal distribution mode, consistent and good results can be obtained from statistical induction and an analysis of numerous numerical values, therefore, the 5% inverse cumulative probability value of statistics (i.e. 95% cumulative probability value) of the measured active power (P), reactive power (Q) and voltage flicker (ΔV_{10}) data (three-phase) of the wind generators was used as the representative value. Considering the probability of noise interference in the measurement, the 97.5% cumulative probability value was defined as the maximum value, and the 2.5% cumulative probability value was the minimum value.

The average output power for the (a) 296 kW and (b) 193 kW time intervals of wind field A were analyzed, as shown below:

In time interval (a), the active power on the low voltage side of generator No. 1 was 46.96~241.88 kW, the reactive power range was 7.41~21.77 kvar, the ΔV_{10} range was 0.065~0.123 %, and the representative value was 0.119%.

The active power range on the high voltage side of generator No. 1 was 34.88~231.64 kW, the reactive power range was 9.41~26.05 kvar, the ΔV_{10} range was 0.04~ 0.051% and the representative value was 0.049%.

The active power range of the PCC was 106.16~478.19 kW, the reactive power range was 25.71~56.15 kvar, the ΔV_{10} range was 0.048~ 0.059% and the representative value was 0.058%.

The active power range on the secondary side of the main transformer was 5950.14~6414.65 kW, the reactive power range was 270.16~444.06 kvar; the ΔV_{10} range was 0.024~0.035%, and the representative value was 0.033%.

In time interval (b), the active power range on the high voltage side of generator No. 1 was -16.07~188.15 kW, the reactive power range was 8~26.2 kvar, the ΔV_{10} range was 0.04~0.055% and the representative value was 0.051%.

The active power range of the PCC was -37~518.2 kW, the reactive power range was 7.9~67.53 kvar, the ΔV_{10} range was 0.052~ 0.067% and the representative value was 0.064%.

The active power range on the secondary side of the main transformer was 7724~9217 kW, the reactive power range was 1031~1813 kvar, the ΔV_{10} range was 0.025~0.042%, and the representative value was 0.036%.

The average output power for the (a) 3330 kW and (b) 985 kW time intervals of wind field B were analyzed, as shown below:

In time interval (a), the active power range of the PCC was 2466.61~3576.19 kW, the reactive power range was 135.03~267.52 kvar, the ΔV_{10} range was 0.06~ 0.139% and the representative value was 0.104%.

In time interval (b), the active power range of the PCC was 280.38~2074.78 kW, the reactive power range was 6.19~96.41 kvar, the ΔV_{10} range was 0.054~ 0.162% and the representative value was 0.117%.

According to the ΔV_{10} measurement results of the PCC in various wind fields shown in Table III, the generators were not found to significantly influence voltage flicker in the system, conforming to the control value of 0.45% stated by Taiwan Power. According to the ΔV_{10} measurement results of various points in wind field A, when the measuring point was close to the secondary side of the main transformer, the voltage flicker was not severe for the large short-circuit capacity and system

impedance angle; when the measuring point was far from the secondary side of main transformer, the voltage flicker was severe for the small short-circuit capacity and system impedance angle. In addition, according to the measured data of the high voltage side of generator No. 1 and the PCC, the effect on voltage flicker varied with the quantity of connected generators.

TABLE III
THE MEASUREMENT RESULTS OF VARIOUS WIND FIELDS

Name of wind field	Average active power of wind field (kW)	Measuring point	P (kW)	Q (kvar)	ΔV_{10} (%)
Field A	296	the low voltage side of generator No. 1	236.14	21.11	0.119
		the high voltage side of generator No. 1	223.49	25.08	0.049
		PCC	459.16	54.95	0.058
		the secondary side of the main transformer	6381.4	-430.5	0.033
		the high voltage side of generator No. 1	165.4	23.67	0.051
Field B	3330 985	PCC	462.50	61	0.064
		the secondary side of the main transformer	9186	1772	0.037
		PCC	3560.4	265.34	0.104
			1907.1	82.94	0.117

Generally, the reactive power fluctuation (ΔQ) is used for evaluating voltage flicker. As shown in Table IV, the active power fluctuation (ΔP) is usually greater than ΔQ when the generator is in operation, therefore, it is necessary to use effective power changing ΔP to evaluate the voltage flicker (ΔV_{10}) of the generator.

TABLE IV
THE POWER FLUCTUATION OF VARIOUS WIND FIELDS

Name of wind field	Average active power of wind field (kW)	Measuring point	ΔP (kW)	ΔQ (kvar)	ΔV_{10} (%)
Field A	296	the high voltage side of generator No. 1	196.76	16.64	0.049
		PCC	372.03	30.44	0.058
		the high voltage side of generator No. 1	204.2	18.2	0.0513
Field B	3330 985	PCC	555.3	59.4	0.064
		PCC	1109.58	132.49	0.104
		PCC	1794.38	90.22	0.117

III. SIMULATION ANALYSIS OF VOLTAGE FLICKER OF GENERATORS IN OPERATION

Fig. 1 shows the system one-line diagram of wind field A. The primary side short-circuit capacity of the system was 550.58 MVA, the rated capacity of the main transformer was 25 MVA, the rated voltage was 69 kV-11.4 kV, and the percentage impedance value was 8.9%. The dedicated line was a 25 kV 600A XLPE CU 500 MCM cable, the line impedance value was $0.0901+j0.1325 \Omega/\text{km}$, the line load was the average line load for August of every year, and the load power factor was 0.9, as shown in Table V. Generally, Taiwan Power installs a power

capacitor in the lines to improve the power factor; for wind field A, the line capacitance was 1800 kvar.

TABLE V
THE LOAD LINES OF WIND FIELD A

Load line	active power(kW)	reactive power(kvar)	power factor(%)
(1)	2254	1090	90
(2)	119	57	90
(3)	2704	1309	90
(4)	2189	1060	90

This paper used Matlab's built-in induction wind generator and double-fed induction wind generator models to simulate the generator. In Matlab, one traditional induction generator with a rated capacity of 2.75 MVA and two double-fed induction wind generators with a rated capacity of 1.5MW were used. The voltage was boosted by the 480V/11.4 kV and 575V/11.4 kV step-up transformers inside the generator, which were connected to the secondary side bus of the main transformer in parallel through a dedicated line. The length of the dedicated line was about 2.7 km.

As a traditional induction generator exports effective power to the power grid in parallel operation while consuming the virtual work of the system, the system voltage is disturbed. Therefore, a capacitor is usually installed inside the generator for compensation, with an installed capacity of 750 kvar. The control modes of a double-fed induction wind generator include voltage control and virtual work control modes. The voltage flicker resulting from generator operation varies under different control modes. Therefore, for the two double-fed induction wind generators one set was in the voltage control mode and the other set was in the virtual work mode for analysis in the simulation. The V_f was set as 1pu for voltage control, and the virtual work was set as zero for the reactive power control. The system simulation blocks are shown in Figs. 3 and 4.

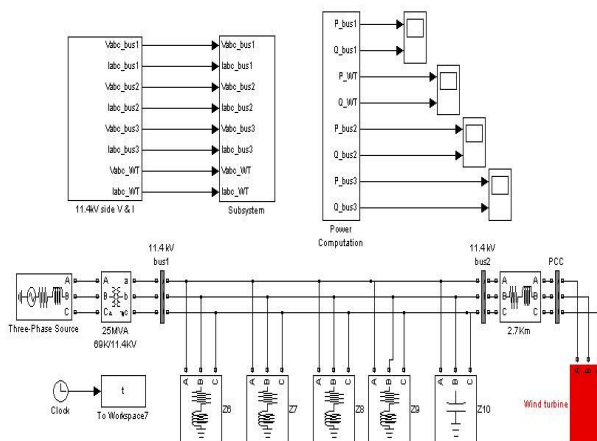

Fig. 3 The system simulation blocks of wind field A

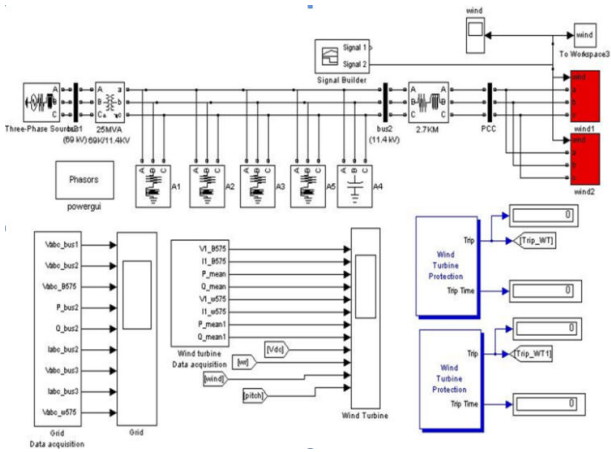

Fig. 4 The system simulation blocks of wind field A

The voltage flicker resulting from generator operation varies at different wind speeds, therefore, this paper used random wind speeds for simulation. The sampling time was the wind speed shifting time interval, as shown in Fig. 5. The random wind speed was expressed as the average wind speed variance ratio.

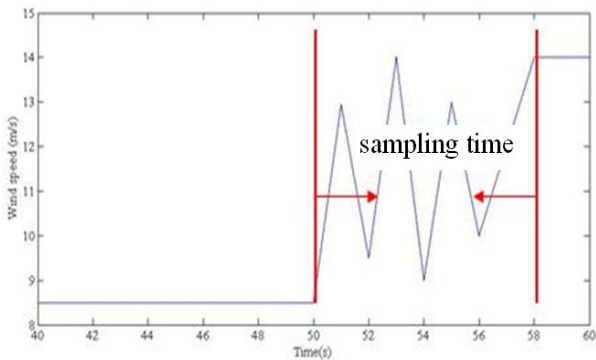

Fig. 5 The wind speed shifting time interval of the sampling time

Fig. 6 shows the voltage flicker curve of the induction wind generator under different average wind speed variance ratios corresponding to the short-circuit capacity of the PCC. Fig. 7 shows the voltage flicker curve of the double-fed induction wind generator under different control modes corresponding to the short-circuit capacity of the PCC when the average wind speed variance ratios were 3.77m/s² and 1.88m/s², respectively. According to Figs. 6 and 7, when the wind speed change was large or the short-circuit capacity was small, the resulting voltage flicker was strong; on the contrary, when the wind speed change was small or the short-circuit capacity was large, the resulting voltage flicker was slight. In the viewpoint of slope, as shown in Fig. 8, when the wind speed changed drastically, the resulting voltage flicker was likely to vary with the short-circuit capacity; when the short-circuit capacity was small, the voltage flicker changed greatly. When the generator is in voltage control mode, the output voltage of the generator is only slightly influenced by the wind speed changes, and voltage flicker is slighter than that in virtual work control mode.

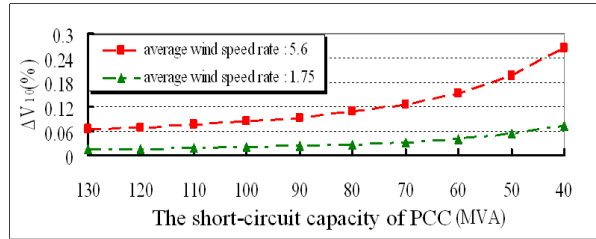

Fig. 6 The voltage flicker curve of the induction wind generator under different average wind speed variance ratios

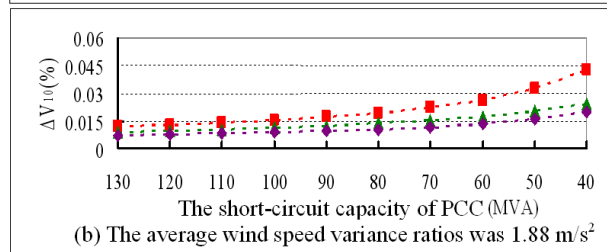
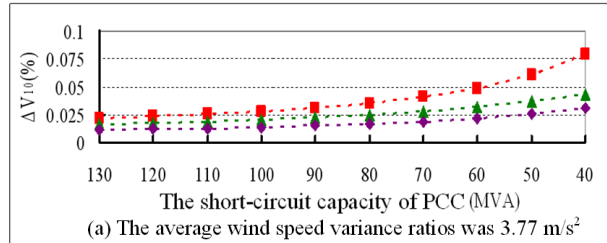

Fig. 7 The voltage flicker curve of the double-fed induction wind generator under different control modes

Fig. 8 shows the voltage flicker curve of the induction wind generator under different average wind speed variance ratios corresponding to the system impedance angle. Fig. 9 shows the voltage flicker curve of the double-fed induction wind generator under different control modes corresponding to the system impedance angle, when the average wind speed variance ratios were 3.77 and 1.88m/s², respectively. According to Figs. 8 and 9, when the wind speed change was large or the system impedance angle was small, the resulting voltage flicker was strong; on the contrary, when the wind speed change was small or the system impedance angle was large, the resulting voltage flicker was slight. In terms of fan control mode, the output voltage of the generator was only slightly influenced by wind speed changes, and the voltage flicker was slighter than that in virtual work control mode.

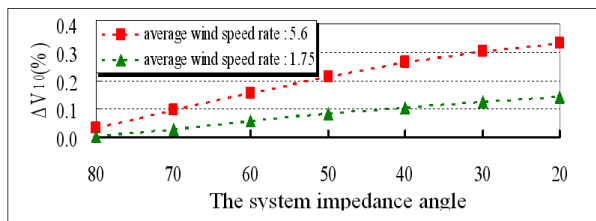

Fig. 8 The voltage flicker curve of the induction wind generator under different average wind speed variance ratios

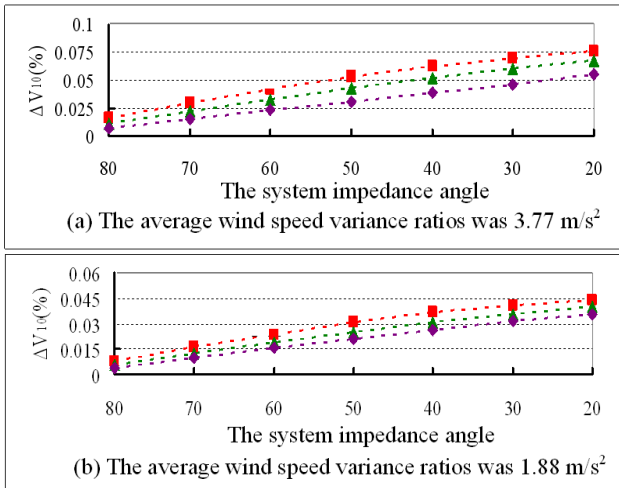

Fig. 9 The voltage flicker curve of the double-fed induction wind generator under different control modes

Fig. 10 shows the voltage flicker curve of the induction wind generator under different average wind speed variance ratios of 5.6 and 1.75 m/s^2 , corresponding to various capacity and load power factors. Figs. 11-13 show the voltage flicker curve of two double-fed induction wind generators with one in voltage control mode and the other in reactive power control mode, under average wind speed variance ratios of 3.77 and 1.88 m/s^2 , corresponding to various capacity and load power factors.

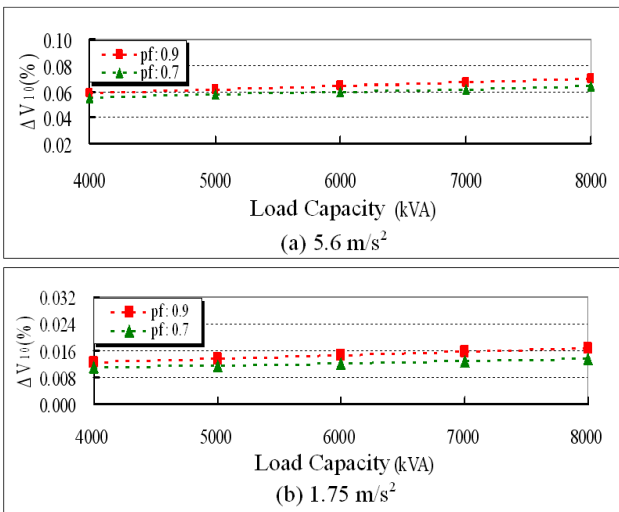

Fig. 10 The voltage flicker curve of the induction wind generator under different average wind speed variance ratios of 5.6 and 1.75 m/s^2 , corresponding to various capacity and load power factors

According to Figs. 10-13, when the wind speed change was large or the capacity was large, the resulting voltage flicker was strong; on the contrary, when the wind speed change was small or the capacity was small, the resulting voltage flicker was slight. In addition, according to the load power factor, when the capacity was fixed and the load power factor was high, the resulting voltage flicker was strong; on the contrary, when the

load power factor was low, the resulting voltage flicker was slight. When the generator was in voltage control mode, the output voltage of the generator was only slightly influenced by wind speed changes, and the voltage flicker was slighter than that in virtual work control mode.

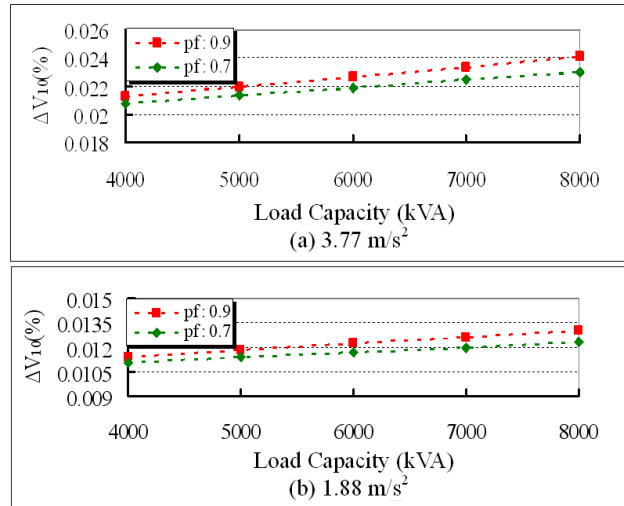

Fig. 11 The voltage flicker curve of two double-fed induction wind generators with in reactive power control mode, under average wind speed variance ratios of 3.77 and 1.88 m/s^2 , corresponding to various capacity and load power factors

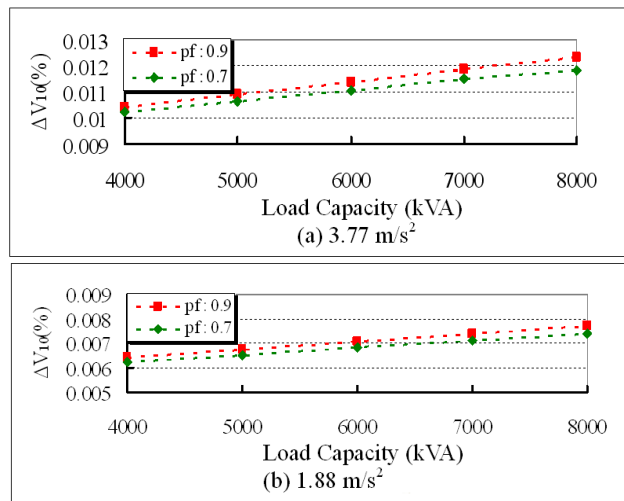

Fig. 12 The voltage flicker curve of two wind generators with in reactive power control mode, under average wind speed variance ratios of 3.77 and 1.88 m/s^2 , corresponding to various capacity and load power factors

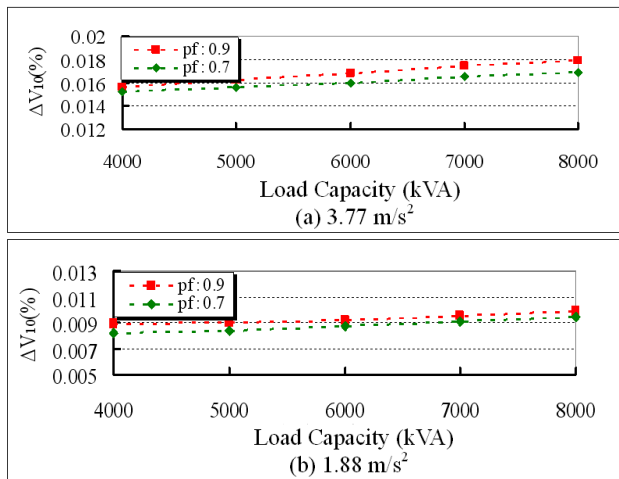

Fig. 13 The voltage flicker curve of two wind generators with in voltage control mode and reactive power control mode, under average wind speed variance ratios of 3.77 and 1.88m/s², corresponding to various capacity and load power factors

IV. CONCLUSIONS

This paper aimed to discuss the effect of wind generators in operation on the amount of voltage flicker in the power system. The effect on voltage flicker was discussed using the power data obtained from actual measurements of wind fields, and these results were verified using a Matlab simulated power system.

When a wind generator is in operation, its output power varies with the wind speed, therefore, wind generators are mostly connected to the power grid in parallel at present. The following conclusions were obtained from the research results of this paper:

- 1) The actual measurement results showed that the voltage flicker values resulting from the operation of wind generators in Taiwan are not severe at the moment, and that they conform to the control value of 0.45% set by the Taiwan Power Company.
- 2) According to the analysis of the measured data and the simulation results, the voltage flicker value resulting from generator operation varies with the wind speed, contact point short-circuit capacity, system impedance angle, capacity and load power factor.
- 3) The variance in reactive power is mainly considered in the evaluation of voltage flicker. According to actual measurements and simulation, the reactive power changes only slightly when the generator is in operation, therefore, the voltage flicker should be evaluated according to the variance in effective power.
- 4) The voltage flicker resulting from generator operation varies with the control mode of a double-fed induction wind generator. When it is in voltage control mode, the output voltage of the generator is influenced only slightly by wind speed changes, and the voltage flicker is slighter than that in virtual work control mode.

REFERENCES

- [1] G. Manchur and C. C. Erven, "Development of A Model for Predicting Flicker from Electric Arc Furnaces", *IEEE Trans. on Power Delivery*, Vol. 7, No. 1, pp. 416-426, 1992.
- [2] G. C. Montanari, M. Loggini, A. Cavallini, L. Pitti, and D. Zaninelli, "Arc-Furnace Model for Study of Flicckr Compensation in Electrical Networks", *IEEE Trans. on Power Delivery*, Vol. 9, No. 4, pp. 2026-2036, 1994.
- [3] J. C. Gu, C. J. Wu, and J. C. Chiang, "Effects of High Voltage Side Voltage Flicker Sources on Low Voltage Side Customers," *Power Research Institute*, Taiwan Power Company, 1994.
- [4] *IEC 61400-21*, 2001, Wind turbine generator systems-part 21: measurement and assessment of power quality characteristics of grid connected wind turbines.
- [5] *IEEE Std 1547*, Standard for Interconnecting Distributed Resources with Electric Power System, *IEEE SCC21*, 2003.