

The Catalytic Effects of Potassium Dichromate on the Pyrolysis of Polymeric Mixtures

Part II: Hazelnut Shell and Ultra-high Molecular Weight Polyethylene and their Blend Cases

B. Aydinli, A. Caglar

Abstract—Renewable energy sources have gained ultimate urgency due to the need of the preservation of the environment for a sustainable development. Pyrolysis is an ultimate promising process in the recycling and acquisition of precious chemicals from wastes. Here, the co-pyrolysis of hazelnut shell with ultra-high molecular weight polyethylene was carried out catalytically and non-catalytically at 500 and 650 °C. Potassium dichromate was added in certain amounts to act as a catalyst. The liquid, solid and gas products quantities were determined by gravimetry. As a main result, remarkable increases in gasification were observed by using this catalyst for pure components and their blends especially at 650 °C. The increase in gas product quantity was compensated mainly with the decreases in the solid products and additionally in some cases liquid products quantities. These observations may stem from mainly the activation of carbon-carbon bonds rather than carbon-hydrogen bonds via potassium dichromate. Also, the catalytic effect of potassium dichromate on HS: PEO and HS: UHMWPE co-pyrolysis was compared.

Keywords—Hazelnut shell, Polyethylene oxide, Potassium dichromate, Pyrolysis, UHMWPE

I. INTRODUCTION

THERE are two great headlines; energy and environment, on which our modern global world has begun to place a heavy emphasis. Today terrestrial borders between nations begin to lose their significance from now on due to global energy demands and safe distribution of energy among nations in the world, and spreading of environmental pollution through water cycle and atmospheric events [1].

Today energy sources are based mainly on oil, coal, natural gas and radioactive atoms. Nuclear energy sources, legal regulations on the use of these energy sources, their possible impacts on environmental pollution and disasters and the collapse of the world caused by nuclear events which may stem from nuclear wars or natural events are totally separately

B. Aydinli is with the Science Education Department, University of Kastamonu, Kastamonu, CO 37200 Turkey (corresponding author to provide phone: +90-366 2142312; fax: +90-366 2123353; e-mail: baydinli@gmail.com).

A. Caglar is with the Science Education Department, University of Kastamonu, Kastamonu, CO 37200 Turkey (e-mail: atilacaglar@gmail.com).

important subjects. The other remaining non-renewable energy sources namely; oil, coal and natural gas are also called environmentally unsafe in the case of direct burning. Fuel cells appear as a solution for an efficient conversion of fuels into desired type of energy with minimal emission of hazardous materials to the environment [2]. Unfortunately, fuel cells have not been able to be put into widespread use in all the areas of engineering and technology yet up till now.

In terms of energy and environment, the disposition of solid wastes is of prime importance. The accumulation of wastes in piles and their volume reduction in landfills are just the minimum requirements according to the Kyoto protocol. Biomass and plastic wastes which are also solid wastes can be converted into precious chemicals and/or fuels by thermochemical conversion processes instead of incineration of waste materials directly or awaiting them to decompose and intermingle with the environment randomly [3]. The direct incineration of these inhomogeneous wastes results in uncontrollable burning which emits great amounts of pollutants to the atmosphere. Also, waiting for wastes to degrade and disintegrate in the environment leads not only to the pollution of the environment, but also the wasting of energy bearing wastes.

Pyrolysis is a promising conversion process where generally solid materials such as biomass, plastic wastes, hazardous material and medical wastes are exposed to heating in vacuum or the inert atmosphere [4]. Generally, solid, liquid and gas products are obtained in pyrolysis processes. Solid products basically comprise carbon black powder which can be activated to be used as an adsorbent for the abatement of hazardous materials. Liquids can be regarded as equivalent to raw petroleum which can be converted into precious materials or fuels after the refining process. The evolving gaseous material is called hydrogen-rich gas [5].

Natural minerals can find many applications such as catalysts in pyrolysis process in which organic compounds from polymeric materials and metal ions from these minerals may form organic metallic compounds [6]. This is a field where organic chemistry and inorganic chemistry converge. These transition metal organic compounds act as self-catalysts

with extraordinary selectivity [7]. The effect of catalysts can be very diverse on the kinetics of pyrolysis process and its products files.

In this study, the catalytic co-pyrolysis of hazelnut shell (HS) and UHMWPE with $K_2Cr_2O_7$ catalyst was investigated and the results were also compared with those in Part I. The co-pyrolysis of HS, UHMWPE, and their various mixtures with and without $K_2Cr_2O_7$ was realized at 500 and 650 K. $K_2Cr_2O_7$ is a common inorganic chemical reagent, most commonly used as an oxidizing agent in various laboratory and industrial applications [8]. The catalytic effects of $K_2Cr_2O_7$ on solid, liquid and gas quantities were determined. $K_2Cr_2O_7$ is an oxidizing agent especially if it is coupled with acids. The Cr(VI) may form organometallic compounds which themselves catalyze the process at meta-stable hot melt composition during the pyrolysis, [6], [9] and also the Cr(VI) atoms and two oxygen atoms in $K_2Cr_2O_7$ can act as electrophile and nucleophile simultaneously and separately. These can easily activate many types of bonds such as π -bonds and σ -bonds which result in C bonds breakage significantly and the formation of new products [10]. Although both of the polymers have simple structures (UHMWPE; $-CH_2-CH_2-$ and PEO; $-CH_2-CH_2-O-$), they have completely different physical and chemical properties where UHMWPE is hydrophobic and having a melting point of 141 °C and PEO is hydrophilic and has a low melting point of approximately 65 °C. The pyrolysis products of pure PEs generally have low molecular weights which have aliphatic and aromatic hydrocarbons and in contrast to this, pure PEO produces generally vinylic and cyclic ethers and hydroxyl compounds at low molecular weights. Additionally, hydrogen was the common pyrolysis product [11], [12]. So, a comparison of the catalytic co-pyrolysis of HS with PEO and UHMWPE in the presence of $K_2Cr_2O_7$ was felt to be made in order to deduce and enlarge the path of compatible polymeric materials, natural or synthetic.

II. EXPERIMENTAL

A. Materials

The UHMWPE sample was supplied by Hoechst GUR 412 ($M_w = 4$ million) in powder form and used directly as supplied. Its melting point is 141 °C. Hazelnut which is an important biomass resource of Turkey has an annual production of 500 000 tons. Also, its shell is a by-product of nut processing factories [13]. Its direct incineration is an inefficient way for disposition. Its physical and chemical properties and HHV were given in Table I [14]. The hazelnut shell sample was ground to small grains and its powder having 40 mesh aperture was used in the pyrolysis experiments.

$K_2Cr_2O_7$ is supplied as red-orange crystalline solid powder in technical grade. Its apparent density is of 2.0 g/cm³ and bulk density of 2.7 g/cm³. Its melting point is 398 °C and it decomposes at 500 °C yielding CrO₃ and K₂CrO₄ [8].

TABLE I
THE PROXIMATE AND ULTIMATE ANALYSIS OF HS

Proximate analysis (wt %)	
Moisture	9.2
Ash	1.3
Extractives (Alcohol-Benzene)	3.4
Lignin	42.5
Cellulose	25.9
Hemicelluloses	28.9
Fixed Carbon	19.5
Volatile	70.0
Elemental analysis (wt %)	
C	51.5
H	5.2
O	43.2
N	0.2
Higher Heating Value (MJ/kg)	18.9

B. Pyrolysis

The experiments were performed at 500 and 650 °C considering the melting and decomposition temperatures of the catalyst. The sample sets showing the compositions of HS, UHMWPE and $K_2Cr_2O_7$ for pyrolysis experiments were given in Table II.

TABLE II
THE AMOUNT OF CONSTITUENTS IN SAMPLE SETS

Sample sets	Constituents amounts (g)		
	HS	UHMWPE	$K_2Cr_2O_7$
1.00	0.00	0.0	
0.00	1.00	0.0	
1.00	0.00	0.5	
1.00	0.00	1.0	
0.00	1.00	0.5	
0.00	1.00	1.0	
1.00	1.00	0.0	
1.00	1.00	0.5	
1.00	1.00	1.0	
1.50	0.50	0.0	
1.50	0.50	0.5	
1.50	0.50	1.0	

The residence time of each pyrolysis experiment is adjusted for 15 minutes. Liquids were determined by subtracting the weights of apparatus parts before and after the pyrolysis runs. The char amount was weighted directly. The gas product was found by difference.

C. Setup

The same pyrolysis experiments set-up as in Part I was also given here in Fig. 1. The stainless steel tubular reactor after being doped with the samples was inserted in the electrical furnace at 500 or 650 °C and connected with the vessel to the liquid collecting tube that was embedded in salty ice. The char products were retained in the reactor chamber.

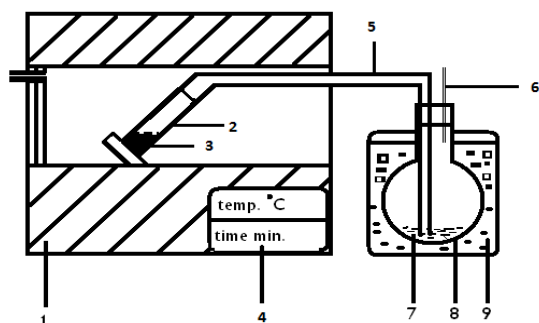

Fig. 1 Experimental setup: 1) Electrical furnace, 2) Tubular reactor, 3) Sample, 4) Control Panel, 5) Connecting vessel 6) Gas outlet
7) Liquid, 8) Liquid collecting vessel, 9) Salty ice.

III. RESULT AND DISCUSSION

A. The catalytic effect of $K_2Cr_2O_7$ on the pyrolytic products quantities

The obtained solid, liquid and gas product quantities from the pyrolysis process were given in Fig. 2, 3, 4 separately. Pure HS produces a high amount of solid products and the additions of potassium dichromate decrease it significantly from 38 % to 15 % for 500 °C and similarly, but less pronouncedly for 650 °C (Fig. 2). If a lower amount of solid product is aimed at, instead of increasing the temperature, the usage of a catalyst may be an energy saving choice when the price of catalysts takes a priority. This result surprisingly shows that the fixed carbon content of HS is probably converted into low molecular weights products such as CO_2 , CO or other carbonaceous chemicals as stated in Part I. Since UHMWPE has a high melting point and extremely high molecular weight, it can stay in the reactor as a wax without noticeable evaporation up to 500 °C [13]. The solid product amount at 500 °C does not represent the real situation in the reactor where a very high solid product was obtained. But if the temperature is raised to 650 °C, the real solid which is carbon black is obtained and this result can be trusted for the comparison of blend ratio effects. So, at 650 °C the solid product of the blends can resemble the mathematical average of the pure constituents according to their ratio. And also, at 650 °C the catalyst increases the solid product amount for the blends and the pure UHMWPE which is contrary to the situation observed for the pure HS. This waxy effect is clearly seen if solid amounts are compared with temperature.

The overlapping of the decomposition of potassium dichromate and resistivity of UHMWPE to evaporation at 500 °C produces complicated results at this temperature. Especially for 1.0:1.0 composition with the presence of 1.0 g catalyst at 650 °C, a higher amount of liquid product was obtained than 500 °C (Fig. 3). The scattered data were obtained for liquid yields. If evaluation is made according to the result of 650 °C, it can be concluded that the catalyst decreases the liquid amounts slightly.

Obviously, with the additions of the catalyst, gas products increase for all situations (Fig. 4). The synchronization of the increase of both solid and gas products strongly implies the preservation of carbon-carbon σ -bonds along with breakage of carbon-hydrogen bonds, which releases hydrogen rich gas. That's why, during the pyrolysis, the Cr ion may form organometallic compounds which themselves catalyze the process at meta-stable slurry composition. The high amount of the gas product can be attributed to such catalyst effect of potassium dichromate.

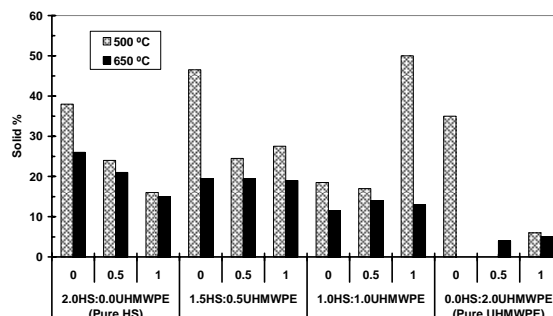

Fig. 2 The solid product amounts from pure and $K_2Cr_2O_7$ added HS and UHMWPE, and their two blends at two temperatures

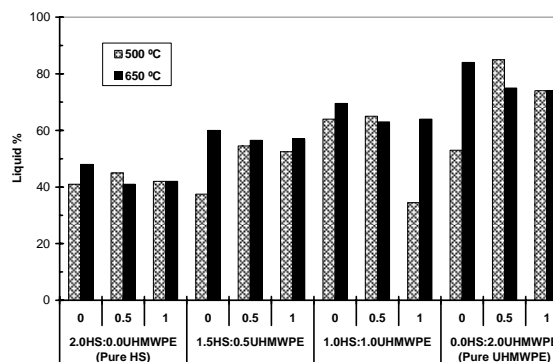

Fig. 3 The liquid product amounts from pure and $K_2Cr_2O_7$ added HS and UHMWPE, and their two blends at two temperatures

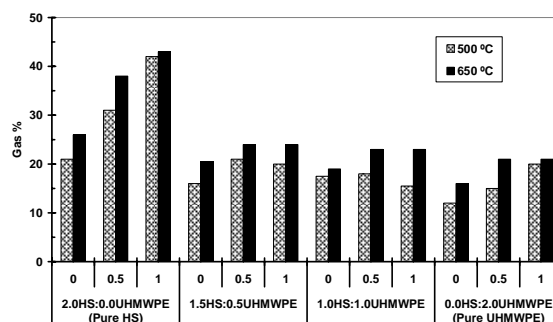

Fig. 4 The gas product amounts from pure and $K_2Cr_2O_7$ added HS and UHMWPE, and their two blends at two temperatures

B. The effect of temperature and blends ratio on the catalytic pyrolysis products

The scattering of data (Fig. 5 and 6) especially at 500 °C can be explained in the following way: UHMWPE melts around 141 °C. It is hydrophobic. It starts to evaporate after 425 °C. Hazelnut shell is a hydrophilic composite material itself. It starts to decompose at 200 °C and continues up to 700 °C. And also, the catalyst potassium dichromate melts at 398 °C and decomposes at 500 °C. Therefore, during the catalytic co-pyrolysis process, polyethylene melts diffuses into the pores of hazelnut shell powders which may inhibit and retard the interaction of potassium dichromate with hazelnut shell. This results in a decrease of gasification effect of potassium dichromate on hazelnut shell which is the major source of gas in these blends. In any way, potassium dichromate acts as a gasification agent in the pyrolysis of both of the pure components and their blends. Actually, 500 °C is not a good choice for the pyrolysis of UHMWPE due to wax formation which accounts for solid product and stays in the reactor. It was just planned that the coincidence of the decomposition temperature of potassium dichromate and the pyrolysis process may lead to extraordinary results. To determine the real effect of potassium dichromate on the co-pyrolysis of HS and UHMWPE, temperature should be beyond the 550 °C.

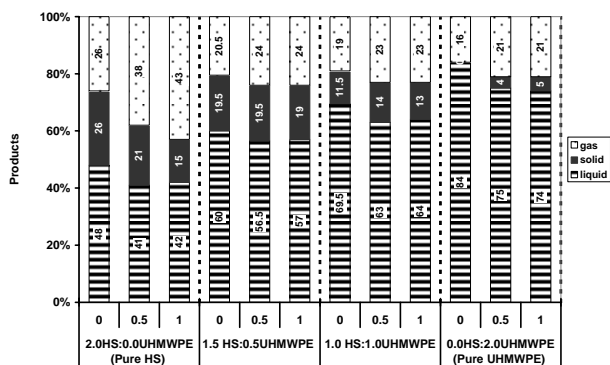

Fig. 5 The solid, liquid and gas product amounts from pure and K₂Cr₂O₇ added HS and UHMWPE, and their two blends at 650 °C

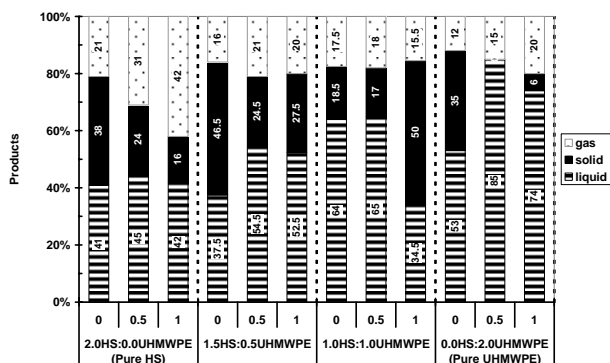

Fig. 6 The solid, liquid and gas product amounts from pure and K₂Cr₂O₇ added HS and UHMWPE, and their two blends at 500 °C.

C. The Comparison of the co-pyrolysis PEO and UHMWPE with HS in the presence of catalyst.

It was felt compulsory to compare the results here with those in part I. Because the two different polymers, namely PEO and UHMWPE belonging to two distinct groups which are water soluble polymers and water resist polymers respectively were used in the co-pyrolysis with HS in the presence of catalyst. The gasification, liquefaction and solidification synergy of the constituents at the two temperatures (500 and 650 °C) were presented in Figs. 7-12 and discussed. Primarily, gasification should be discussed (Figs. 7 and 8). PEO:HS systems have produced higher gas products than UHMWPE: HS blends especially at 1g addition of catalyst. Potassium dichromate has a similar effect on HS and PEO. For the case of UHMWPE: HS, since pure polyethylene does not generate gas products, it also prevents the gasification of HS in their blends even with little increase in gas products with the addition of the catalyst.

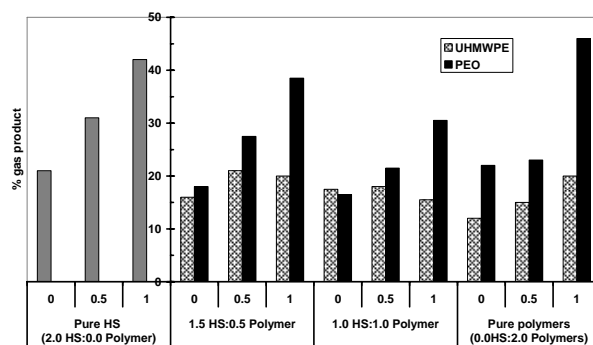

Fig. 7 The comparison of the change in gas products amount in blends at 500 °C

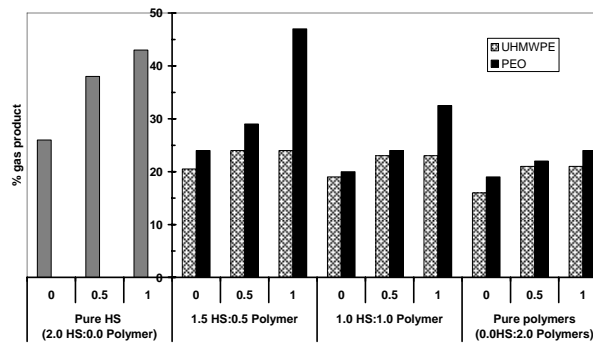

Fig. 8 The comparison of the change in gas products amount in blends at 650 °C

In the case of liquid production, both systems have promising liquid yields which are higher than the pure HS for both temperatures (Figs. 9 and 10). But the addition of the catalyst generally reduces liquid products in all cases. The coupling of a decrease in liquid products along with an increase in gas products with the addition of the catalyst implies that potassium dichromate is a very effective catalyst.

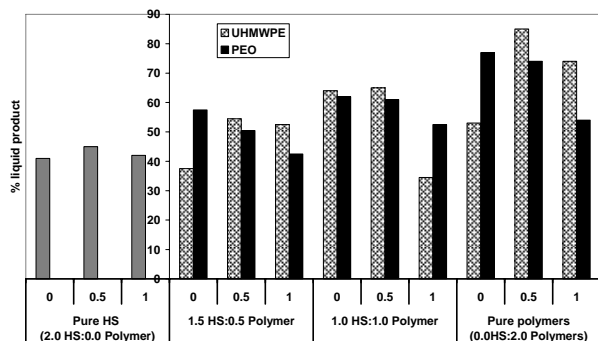

Fig. 9 The comparison of the change in liquid products amount in blends at 500 °C

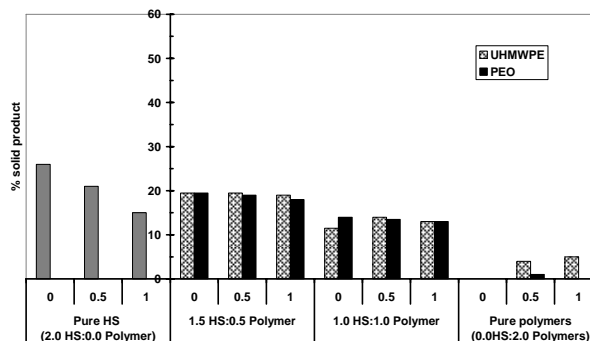

Fig. 12 The comparison of the change in solid products amount in blends at 650 °C

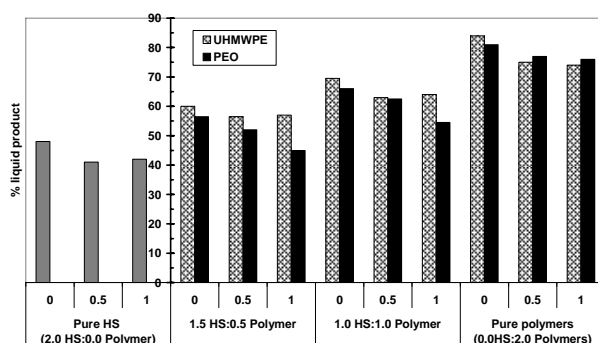

Fig. 10 The comparison of the change in liquid products amount in blends at 650 °C

PEO and UHMWPE do not produce considerable solid products especially at higher temperatures (Figs. 11 and 12).

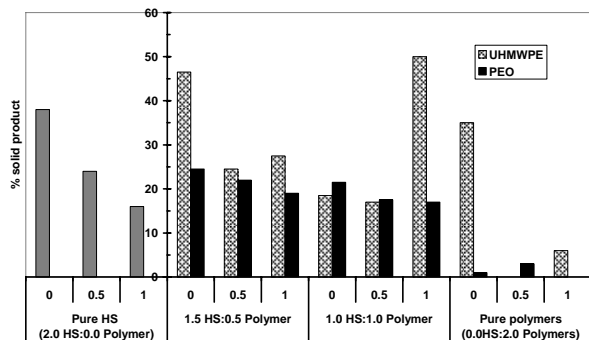

Fig. 11 The comparison of the change in solid products amount in blends at 500 °C

The solid product quantity for UHMWPE at 500 °C is actually a waxy hydrocarbons staying in the reactor without noticeable evaporation. Surprisingly, the catalyst causes solid product formation for UHMWPE at 650 °C. This is probably due to the fact that potassium dichromate is more effective on carbon-hydrogen bonds than carbon-carbon bonds.

The pure HS is the main solid source in which the addition of the catalyst decreases solid products substantially. But the addition of the catalyst slightly decreases the solid products in blends. So, it can be alluded that polymers inhibit the volatilization of HS in the pyrolysis process. Again a complicated result was observed for UHMWPE cases at 500 °C.

REFERENCES

- [1] http://unfccc.int/kyoto_protocol.
- [2] P.P. Edwards, V.I. Kuznetsov, W.I.F. David, N.P. Brandon, "Hydrogen and Fuel Cells: Towards a Sustainable Energy Future" *Energy Policy*, Vol. 36, no. 12, pp. 4356-4362, Dec. 2008
- [3] M.K. Bahn, C. Mukarakate, D.J. Robichoud, M.R. Nimlos, "Current technologies for analysis of biomass thermochemical processing: A review" *Anal. Chim. Acta*, Vol. 651, no. 2, pp. 117-138 Oct. 2009.
- [4] F. Paradelo, F. Pinto, A. M. Ramos, I. Gulyurtlu, I. Cabrita, "Study of the slow batch pyrolysis of mixtures of plastics, tyres and forestry biomass wastes" *J. Anal. Appl. Pyrol.* Vol. 85, no. 1-2, pp. 392-398, May 2009
- [5] S. Li, S. Xu, S. Liu, C. Yang, Q. Lu "Fast pyrolysis of biomass in free-fall reactor for hydrogen-rich gas" *Fuel Process. Technol.* Vol. 85, no. 8-10, pp. 1201-1211, Jul. 2004.
- [6] Shilov, A.E., and Shul'pin, G.B., 2000. Activation and Catalytic Reactions of Saturated Hydrocarbons in the Presence of Metal Complexes. *Catalysis by Metal Complexes*. Edited by B.R. James. Kluwer Academic Publishers, USA, pp. 318-363.
- [7] Solomons, T.V.G., 1988. *Organic Chemistry*. John Wiley & Sons, USA, pp. 713-733.
- [8] http://en.wikipedia.org/wiki/Potassium_dichromate
- [9] Q. Fu, D. S. Argyropoulos, D. C. Tilotta, L. A. Lucia, "Understanding the pyrolysis of CCA-treated wood: Part I. Effect of metal ions," *J. Anal. Appl. Pyrol.* Vol. 81, no. 1, pp. 60-64, Jan. 2008
- [10] M. Nishimura, S. Iwasaki, M. Horio, "The role of potassium carbonate on cellulose pyrolysis," *J. Taiw. Inst. Chem. Engineer.* Vol. 40, no. 6, pp. 630-637, Nov. 2009.
- [11] B. Aydinli, A. Caglar, "The comparison of hazelnut shell co-pyrolysis with polyethylene oxide and previous ultra-high molecular weight" *J. Anal. Appl. Pyrol.* Vol. 87, no. 2, pp. 263-268, Mar. 2010.
- [12] Z. K. Lin, S.F. Li, "Effects of nano nickel powders addition on flash pyrolysis of poly(ethylene glycol)," *Eur. Polym. J.* vol. 44, no. 3, pp. 645-652, Mar. 2008.
- [13] A. Caglar, B. Aydinli, "Isothermal co-pyrolysis of hazelnut shell and Ultra-High Molecular Weight Polyethylene: The effect of temperature and composition on the amount of pyrolysis products," *J. Anal. Appl. Pyrol.* Vol. 86, no. 2, pp. 304-309, Nov. 2009.
- [14] A. Demirbaş, D. Güllü, A. Çağlar, F. Akdeniz, "Estimation of calorific values of fuels from lignocellulosics Vol. 19, no. 8, pp. 765-770, Oct. 1997.