

Testing of DISAL D240 and D420 Ceramic Tool Materials with an Interrupted Cut Simulator

Robert CEP, Marek SADILEK, Lenka OCENASOVA, Josef BRYCHTA, Michal HATALA, Branimir BARISIC

Abstract— This paper presents a solution for ceramic cutting tools availability in interrupted machining. Experiments were performed on a special fixture — the interrupted cut simulator. This fixture was constructed at our Department of Machining and Assembly within the scope of a project by the Czech Science Foundation. The goals of the tests were to contribute to the wider usage of these cutting materials in machining, especially in interrupted machining.

Through the centuries, producers of ceramic cutting tools have taken big steps forward. Namely, increasing durability in maintaining high levels of strength and hardness lends an advantage. Some producers of these materials advise cutting inserts for interrupted machining at the present time [1, 2].

Keywords— ceramic cutting tool, cutting tool tests, interrupted cutting, machining

I. INTRODUCTION

All cutting tool edges are liable to wear during machining. To this extent tool wear is figured from start to end of tool life. Tool life is time, when cutting tool work from clamping to total wear, and is calculated in minutes. It is applicable, when edge machining metal within parameter limits, as is quality, required design etc. [3]

The choice of the right cutting tool is critical for the highest machining achievement. Choice of material and cutting geometry are largely simulated. Vibration generated in machining induces the early termination of tool life. This may be, for example, due to poor tool holder stiffness or when a tool is when the chuck is held incorrectly. [4].

II. CHOISE OF CUTTING MATERIALS

For the cutting materials, we have chosen products of the Czech producer – Saint Gobain Advanced Ceramics Turnov. For an aluminium oxide based ceramic we have chosen the

R. CEP is with the Faculty of Mechanical Engineering, VSB – Technical University of Ostrava, 708 33 Czech Republic (corresponding author to provide phone: +420 59 732 3193; fax: +420 59 691 6490 e-mail: robert.cep@vsb.cz).

M. SADILEK, L. OCENASOVA, J. BRYCHTA are with the Faculty of Mechanical Engineering, VSB – Technical University of Ostrava, Ostrava, 708 33 Czech Republic (e-mail: marek.sadilek@vsb.cz, lenka.ocenasova@vsb.cz, josef.brychta@vsb.cz).

M. HATALA is with the Faculty of Manufacturing Technologies with seat in Presov, Technical University in Kosice, Slovakia. (e-mail: michal.hatala@tuke.sk).

B. BARISIC is with the Engineering Faculty, University of Rijeka, Croatia (email: barisic@riteh.hr)

material **DISAL D240**, and to represent a silicon nitride based ceramic, the material **DISAL D420** was selected. The manufacturer characterizes it's product as:

Aluminium Oxide based: DISAL D240 ($Al_2O_3+ZrO_2+CoO$) characteristics:

Mixed oxide ceramics – offer besides hardness and wear resistance at high temperature, also higher toughness. This type is suitable for machining of grey cast iron, spherical as well as tempered cast iron, heat treated steel and high speed steel in a light interrupted cutting.

Silicon Nitride based: DISAL D420 (Si_3N_4) characteristics:

Shows maximum toughness and high hardness. It is suitable for interrupted cut machining, and cooling is possible, and it is good for machining of all cast iron types including cast iron with crust. Intended especially for milling (roughing) to achieve maximum cutting power. [5, 6]

III. USING FIXTURE – INTERRUPTED CUT SIMULATOR

And now to several experiments, which were provided with regard to the special fixture-interrupted cut simulator (Figure 2). It was constructed at our department (the Department of Machining and Assembly) within the framework of a project by the Czech Science Foundation. The main parts of this simulator are (Fig. 1):

- Fixture body (1)
- Workpieces (2)
- Exchangeable mouldings (3)
- Clamping gussets (4)
- Safety circles with screws (5)

Fixture assembling proceeded in the following way: the body was clamped to the lathe and then with clamping gussets workpieces. Where necessary, the bottom is reinforced by exchangeable mouldings and screw up safety circles. We are now ready for tests.

Proportions of simulator are:

- Total length 900 mm
- Machining length (length of workpieces) 600 mm
- Valve diameter 230 mm
- Work piece's profile 60x50 mm

Machining diameter ranges from 270 to 235 during machining. An exchangeable moulding (their variable thickness) is a big advantage of this fixture. Diameter (cutting speed) is relatively constant during the entirety of the tests.

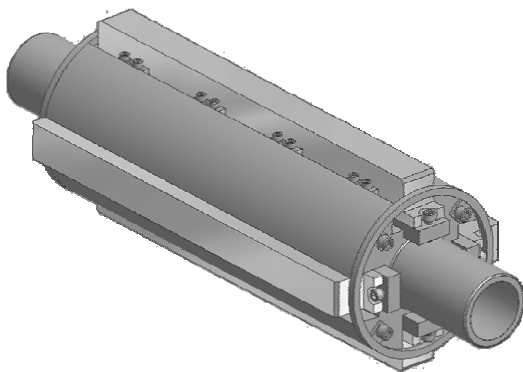
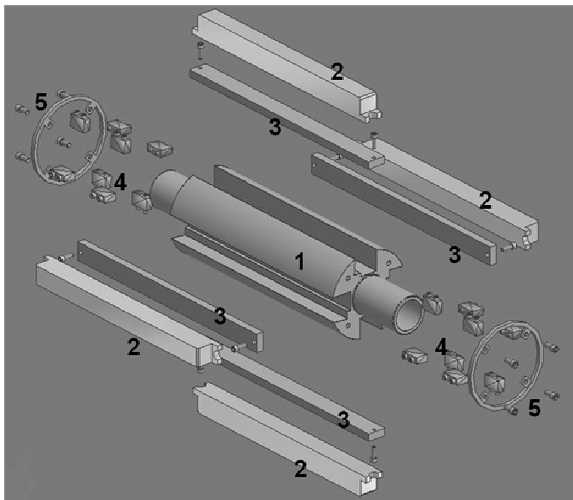

Fig. 1 Scheme of Interrupted Cut Simulator [1]

Prior to the first measuring of new work pieces, it is necessary to machine the first chip. This chip does not have a constant cross cut and could be defaced by whole metering (Fig. 2).

With regards to ISO 3685 (Tool Life Testing of Single Point Turning Tools), the follow cutting geometry was selected:

cutting edge angle : $\kappa_r = 45^\circ$,
 cutting edge inclination : $\lambda_s = -6^\circ$,
 rake angle : $\gamma_o = -6^\circ$,
 clearance angle : $\alpha_o = 6^\circ$,
 included angle : $\epsilon_r = 90^\circ$.

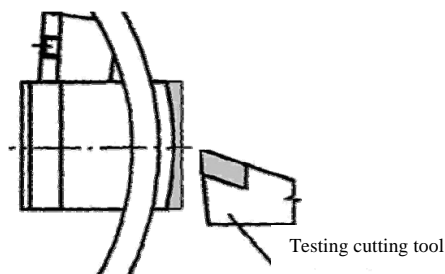

Fig. 2 Regulation of New Work Pieces [1]

This was achieved with the tool holder (CSRNR 25x25M12 – K) and the cutting insert (SNGN 120716 T02020).

IV. MONITORING OF SHOCKS NUMBER

The parameter, which was monitored, is number of shocks leading to cutting tool destruction. The Shock number was determined from follow equation:

$$R = \frac{4 \cdot l}{f}$$

where

R – number of shocks [--],
 l – cutting length [mm],
 f – feed [mm].

ALUMINIUM – OXIDE BASED D240

At first, the constant cutting parameters of cutting depth and feed were set. The variable parameter was cutting speed (Table I). Next, the feed and the constant parameters for cutting depth and cutting speed were changed (Table II). We can tell that by increasing cutting speed or feed, the number of shocks decreased. Values in the following tables represent the arithmetic mean of five given measurements.

TABLE I
 MEASURING DURING VARIABLE CUTTING SPEED

| $a_p = 0,5 \text{ mm}; f = 0,1 \text{ mm}$ | |
|--|------------------------------|
| cutting speed v_c [m/min] | Number of shocks R [--] |
| 316 | 72000 |
| 643 | 48000 |
| 776 | 24000 |
| $a_p = 1 \text{ mm}; f = 0,2 \text{ mm}$ | |
| cutting speed v_c [m/min] | number of shocks R [--] |
| 483 | 7480 |
| 618 | 5400 |
| 767 | 3200 |

TABLE II
 MEASURING DURING VARIABLE FEED

| $a_p = 1 \text{ mm}; v_c = 479 \text{ m/min}$ | |
|---|------------------------------|
| feed f [mm] | number of shocks R [--] |
| 0,1 | 13600 |
| 0,3 | 4667 |
| 0,4 | 1000 |

After evaluation of previous tables, we obtained the following graphs (Fig. 3 and 4). All rates were measured 5 times and in tables are approximately values.

SILICON – NITRIDE BASED D420

As with the Al_2O_3 ceramics, the number of shocks to destruction was monitored. We can see measuring values in Table III. Variable parameters were cutting speed and feed. Evaluation numbers are seen in Figures 5 and 6.

TABLE III
MEASURING DURING VARIABLE CUTTING SPEED AND VARIABLE FEED

| $a_p = 1 \text{ mm}; f = 0,2 \text{ mm}$ | |
|---|------------------------------|
| cutting speed v_c [m/min] | number of shocks R [--] |
| 469 | 6400 |
| 603 | 5200 |
| 754 | 2400 |
| $a_p = 1 \text{ mm}; f = 0,25 \text{ mm}$ | |
| cutting speed v_c [m/min] | number of shocks R [--] |
| 469 | 1696 |
| 603 | 1600 |
| 754 | 1440 |
| $a_p = 1 \text{ mm}; f = 0,3 \text{ mm}$ | |
| cutting speed v_c [m/min] | number of shocks R [--] |
| 469 | 1867 |
| 603 | 1040 |
| 754 | 560 |

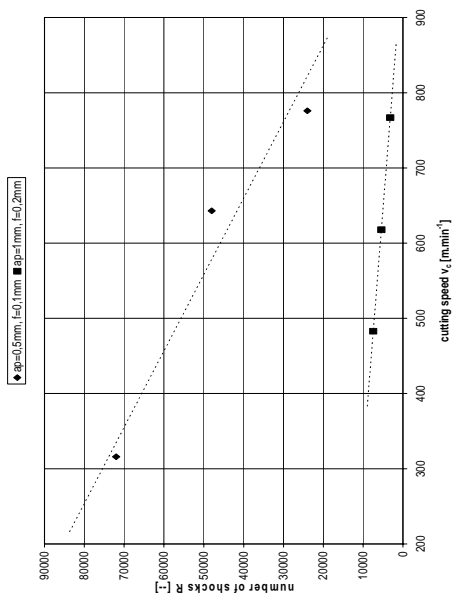

Fig. 3 Number of shocks – cutting speed characteristic

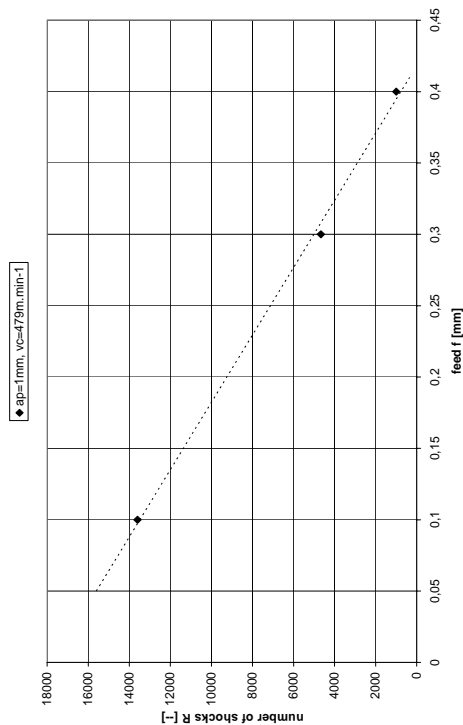

Fig. 4 Number of shocks – feed characteristic

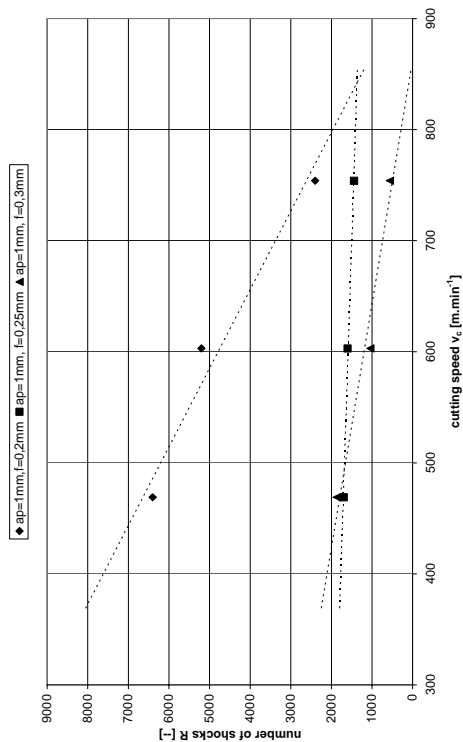

Fig. 5 Number of shocks – cutting speed characteristic

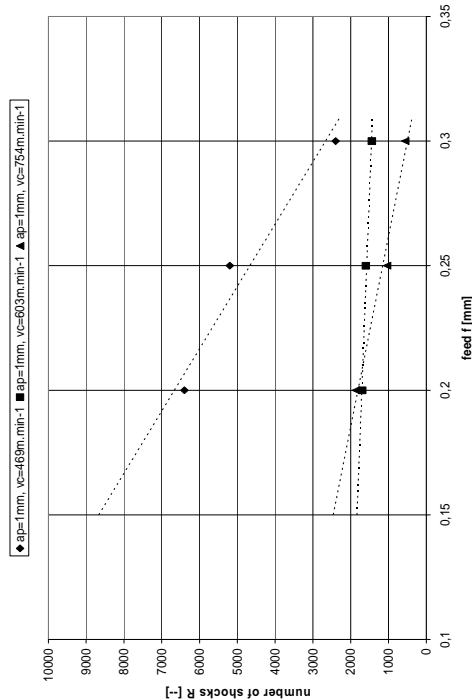

Fig. 6 Number of shocks – feed characteristic

V. CONCLUSIONS

Cutting edge durability and cutting condition optimization depend on many parameters. It is not easy to determine the exact areas. Every cutting process is unique.

The submitted paper deals with the problems of tool life tests of ceramics cutting tools at interrupted cutting. Experiments were provided on a fixture for along turning. This fixture was constructed at the Department of Machining and Assembly at VSB-Technical University of Ostrava.

The purpose of these tests was to contribute to greater use of ceramic materials. The tests documented that ceramics cutting tools are acceptable for interrupted cutting procedures. The arithmetical mean deviation of the profile (R_a) is adequate.

Ceramics cutting tool producers took a big step ahead. They advanced durability while retaining strength and hardness. Manufacturers recommended their products as a solution for the tasks of interrupted cutting. Cutting tools from ceramic and other efficient materials do not outperform classical cutting tools (HSS, sintered carbides) and they are no universal uses for all kinds of workpieces.

In order to obtain more objective and more accurate results, it is necessary to do more tests with regard to more extreme cutting conditions, various workpiece materials and other ceramics cutting tool manufacturers. At present, the loadability and stiffness of the machine tool does not allow for more demanding cutting conditions. In particular, machine tool stiffness is the basic premise for measuring right and objective values. [4]

The next test, with results, will be provided and published at the Department in the form of a diploma, dissertation and

habilitation thesis. Fixture simplified construction for along turning and facing turning is the main target for future analysis. These tests are very costly and time consuming. Institutional grants are necessary (for example Czech Science Foundation or Development Stock of Universities...).

ACKNOWLEDGMENTS

This paper was supported by the Czech Science Foundation, grant number 101/08/P118, entitled *Ceramic Cutting Tool Tests at Interrupted Cut*.

The authors would also like to acknowledge the support provided by the National CEEPUS Office Czech Republic, National CEEPUS Office of Croatia and National CEEPUS Office Slovakia, which helped the research through mobility in the frame of the CEEPUS II.

REFERENCES

- [1] R. CEP, "Ceramic Cutting Tool Tests at Interrupted Machining: dissertation thesis (in Czech)," Ostrava, 2005. 101 p.
- [2] R. CEP, "Ceramic Cutting Tools and their Application Areas," in *WORKSHOP Faculty of Mechanical Engineering*. Ostrava, 2005, pp. 79 + proceedings on CD. ISBN 80-248-0750-95.
- [3] A. CZAN, D. STEKLAC, D. STANCEKOVA, "Tools for High Productive Machining of Bearing materials by Turning (in Slovak)," in *Tools 2005*. Zlin, 2005.
- [4] J. BRYCHTA, "Machinability Assessment and Cutting Temperature Test," in *DOKSEM 2004 – International Ph.D. Conference*. Terchova, 2004, pp. 57–61.
- [5] E. D. WHITNEY, *CERAMICS CUTTING TOOLS – Materials, Development and Performance*, Gainesville Noyes Publications, 1994. 353 p.
- [6] SANDVIK Coromant, Technical Editorial dept., *Modern Metal Cutting – A Practical Handbook*. Tofters Tryckery AB, Sweden, 1994, 927 s. ISBN 91-972290-0-3.