

# SVPWM Based Two Level VSI for Micro Grids

P. V. V. Rama Rao, M. V. Srikanth, S. Dileep Kumar Varma

**Abstract**—With advances in solid-state power electronic devices and microprocessors, various pulse-width-modulation (PWM) techniques have been developed for industrial applications. This paper presents the comparison of two different PWM techniques, the sinusoidal PWM (SPWM) technique and the space-vector PWM (SVPWM) technique applied to two level VSI for micro grid applications. These two methods are compared by discussing their ease of implementation and by analyzing the output harmonic spectra of various output voltages (line-to-neutral voltages, and line-to-line voltages) and their total harmonic distortion (THD). The SVPWM technique in the under-modulation region can increase the fundamental output voltage by 15.5% over the SPWM technique.

**Keywords**—SPWM, SVPWM, VSI, Modulation Index.

## I. INTRODUCTION

THE Pulse Width Modulation is a technique where the duty ratio of a pulsating waveform is controlled by another input waveform. The intersections between the reference voltage waveform and the carrier waveform give the opening and closing times of the switches. The main aim of any modulation technique is to obtain a variable output with a maximum fundamental component and minimum harmonics [1]. PWM is commonly used in applications like motor speed control, converters, audio amplifiers, etc. There is no single PWM method that is the best suited for all applications and with advances in solid-state power electronic devices and microprocessors, various pulse-width modulation (PWM) techniques have been developed. Three space vector PWM schemes, 7-segment, 5-segment and 3-segment SVPWMs, are investigated [2]. The most efficient method of adjusting inverter output voltage is by pulse-width modulation control used within an inverter.

A modified PWM technique is developed to reduce the switching losses and easy to implement in software or hardware. But this technique is unable to fully utilize the DC bus supply voltage available to the voltage source inverter [3]. This drawback led to the development of SVPWM. The implementation of the conventional SVPWM is especially difficult because it requires complicated mathematical operations. The investigation of Space Vector Pulse Frequency Modulation (SVPFM) method with averaged pulse lengths to reduce power losses in inverter was employed [4]. Fractal approach based space vector pulse width modulation technique can be extended to n-level inverters [5]. Moreover,

the utilization of the DC bus voltage can be further increased when extending into the over-modulation region of SVPWM. A novel over-modulation technique by means of graphical analysis and Fourier decomposition, the accurate relationship between modulation index (MI) and auxiliary parameter  $m_{ref}$  is derived respectively under two over-modulation area [6]. FPGA based three phase sinusoidal pulse width modulated variable voltage variable frequency controller simulations are carried out using Model Sim 5.7 and the implementation is carried out using Xilinx foundation series 9 [7].

SimPowerSystems, a modern design tool that was designed to allow scientists and engineers to rapidly and easily build models that simulate power systems. SimPowerSystems uses the Simulink environment, to build a model using simple click and drag procedures. Not only building the circuit topology rapidly, but analysis of the circuit can include its interactions with mechanical, thermal, control, and other disciplines. This is possible because all the electrical parts of the simulation interact with the extensive Simulink modeling library [8].

Analysis, modeling and simulation of different patterns and steps of generating SVPWM patterns using microcomputer are presented to verify the effectiveness of the proposed technique [9]. SVPWM generates less harmonic distortion in both output voltage and current. Sinusoidal PWM and SVPWM utilize a changing carrier frequency to spread the harmonics continuously to a wideband area so that the peak harmonics are reduced greatly [10].

This paper synthesizes and compares the main theories behind three-phase generation of SPWM, and SVPWM. These two techniques are used to generate their respective output PWM signals, which are then compared, based on harmonic content and distortion using the total harmonic distortion (THD) measure of various output voltages. This paper discusses the principles, theories, mathematical equations, and procedures involved for the software (MATLAB/Simulink package) implementation of these techniques.

## II. SINUSOIDAL PWM

The sinusoidal pulse-width modulation (SPWM) technique produces a sinusoidal waveform by filtering an output pulse waveform with varying width. A high switching frequency leads to a better filtered sinusoidal output waveform. The desired output voltage is achieved by varying the frequency and amplitude of a reference or modulating voltage. The variations in the amplitude and frequency of the reference voltage change the pulse-width patterns of the output voltage but keep the sinusoidal modulation.

Rama Rao P.V.V., member IEEE is with the Shri Vishnu Engineering College for Women, Bhimavaram, Andhra Pradesh, India (phone: +91-7569508112; e-mail: pvvmadhuram@gmail.com).

Srikanth M.V. and Dileep Kumar Varma S. are with the Shri Vishnu Engineering College for Women, Bhimavaram, Andhra Pradesh, India (e-mail: srikanthmv@svecw.com, sagiraju\_dileep@svecw.edu.in)

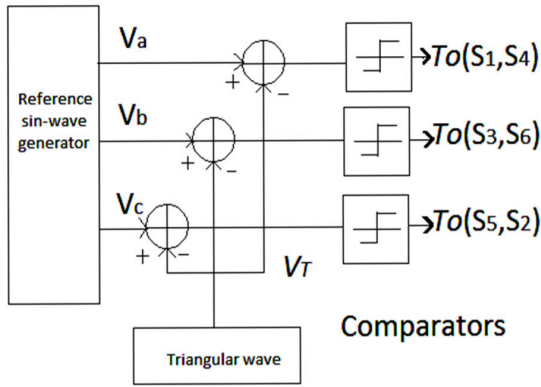

Fig. 1 Control Signal Generator for SPWM

In Fig. 1, a low-frequency sinusoidal modulating waveform is compared with a high-frequency triangular waveform, which is called the carrier waveform. In three-phase SPWM, a triangular voltage waveform ( $V_T$ ) is compared with three sinusoidal control voltages ( $V_a$ ,  $V_b$ , and  $V_c$ ), which are  $120^\circ$  out of phase with each other and the relative levels of the waveforms are used to control the switching of the devices in each phase leg of the inverter. The output of the comparators forms the control signals for the three legs of the inverter. A six-step inverter is composed of six switches  $S_1$  through  $S_6$  with each phase output connected to the middle of each inverter leg as shown in Fig. 2.

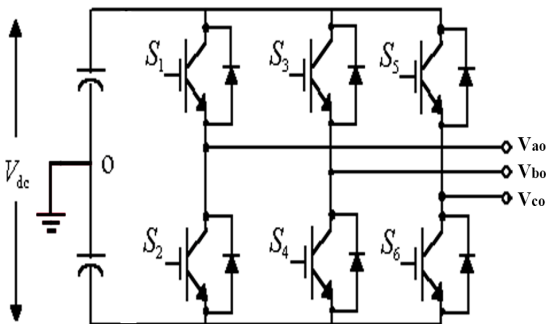

Fig. 2 Three-Phase Sinusoidal PWM Inverter

The Fourier series expansion of a symmetrical square wave voltage with a peak magnitude of  $V_{dc}/2$  has a fundamental of magnitude  $2V_{dc}/\pi$ . The maximum of the output voltage generated by the SPWM method is  $V_{dc}/2$ . The modulation index is defined as the ratio of the magnitude of output voltage generated by SPWM to the fundamental peak value of the maximum square wave. Thus, the maximum modulation index of the SPWM technique is given by the following equation:

$$MI = \frac{V_{P\text{PWM}}}{V_{MAX\text{-SIXSTEP}}} = \frac{\frac{V_{dc}}{2}}{\frac{2V_{dc}}{\pi}} = \frac{\pi}{4} \gg 0.7855 \quad (1)$$

III. SPACE VECTOR PWM

Another method for increasing the output voltage about that of the SPWM technique is the space vector PWM (SVPWM) technique. In the SVPWM technique, the duty cycles are computed rather than derived through comparison as in SPWM. The SVPWM technique can increase the fundamental component by up to 27.39% that of SPWM. The fundamental voltage can be increased up to a square wave mode where a modulation index of unity is reached. SVPWM is accomplished by rotating a reference vector around the state diagram, which is composed of six basic non-zero vectors forming a hexagon.

A circle can be inscribed inside the state map and corresponds to sinusoidal operation. The area inside the inscribed circle is called the linear modulation region or under-modulation region. As seen in Fig. 3, the area between the inside circle and outside circle of the hexagon is called the nonlinear modulation region or over-modulation region. The concepts in the operation of linear and nonlinear modulation regions depend on the modulation index, which indirectly reflects on the inverter utilization capability.

A. Principle of Space Vector PWM

A three-phase mathematical system can be represented by a space vector. For example, given a set of three-phase voltages, a space vector can be defined by:

$$V(t) = \frac{2}{3} \left[ V_a(t)e^{j0} + V_b(t)e^{j\frac{2\pi}{3}} + V_c(t)e^{j\frac{4\pi}{3}} \right] \quad (2)$$

where  $V_a(t)$ ,  $V_b(t)$ , and  $V_c(t)$  are three sinusoidal voltages of the same amplitude and frequency but with  $\pm 120^\circ$  phase shifts. The space vector at any given time maintains its magnitude. As time increases, the angle of the space vector increases, causing the vector to rotate with a frequency equal to that of the sinusoidal waveforms. When the output 180° voltages of a three-phase six-step inverter are converted to a space vector and plotted on the complex plane, the corresponding space vector takes only on one of six discrete angles as time increases. The SVPWM generates a vector with any desired angle.

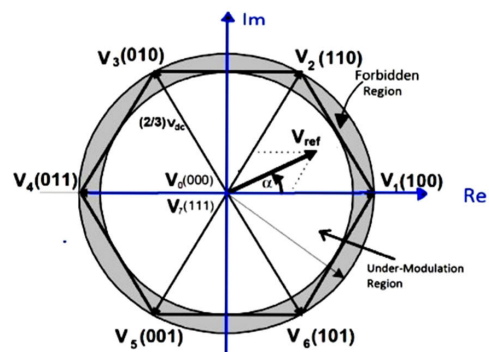

Fig. 3 Under-modulation and Over-modulation regions in Space Vector representation

A typical two-level inverter has 6 power switches (labeled  $S_1$  to  $S_6$ ) that generate three phase voltage outputs. A three-phase bridge inverter is shown in Fig. 4. The basic principle of SVPWM is based on the eight switch combinations of a three phase inverter. The switch combinations can be represented as binary codes that correspond to the top switches  $S_1$ ,  $S_3$ , and  $S_5$ . Each switching circuit generates three independent pole voltages  $V_{ao}$ ,  $V_{bo}$ , and  $V_{co}$ , which are the inverter output voltages with respect to the mid-terminal of the DC source 'O'. The different switching states of inverter are as shown in Fig. 5.

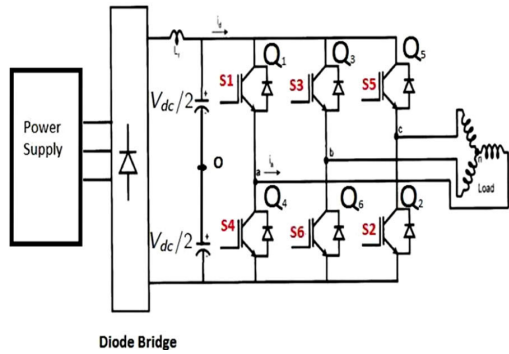

Fig. 4 Three-Phase Bridge Inverter

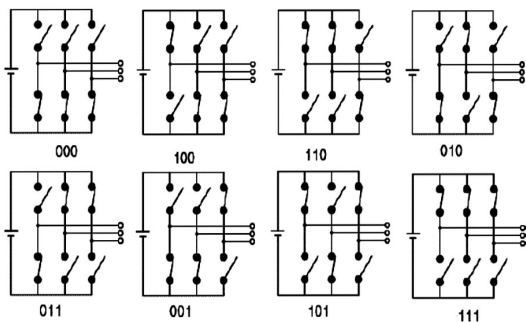

Fig. 5 Eight Switching Configuration of a Three-Phase Inverter

*B. Procedure for Implementing a Two Level SVPWM*

1. Calculate the angle  $q$  and reference voltage vector  $V_{ref}$  based on the input voltage components.
2. Calculate the modulation index and determine if it is in the over-modulation region.
3. Find the sector in which  $V_{ref}$  lies and the adjacent space vectors of  $V_k$  and  $V_{k+1}$  based on the sector angle  $q$ .
4. Find the time intervals  $T_a$  and  $T_b$  and  $T_0$  based on  $T_{ss}$  and the angle  $q$ . (For overmodulation, find  $T_{a0}$ ,  $T_{b0}$  and  $T_{00}$  is zero).
5. Determine the modulation times for the switching states.

IV. SIMULATION AND RESULTS

*A. Sinusoidal PWM*

The Simulink model of sinusoidal PWM is shown in Fig. 6. The SPWM technique treats each modulating voltage as a separate entity that is compared to the common carrier

triangular waveform. A three-phase voltage set ( $V_a$ ,  $V_b$  and  $V_c$ ) of variable amplitude is compared in three separate comparators with a common triangular carrier waveform of fixed amplitude. The output ( $V_{ao}$ ,  $V_{bo}$ , and  $V_{co}$ ) of the comparators form the control signals for the three legs of the inverter composed of the switch pairs ( $S_1;S_4$ ), ( $S_3;S_6$ ), and ( $S_5;S_2$ ), respectively. The simulation is performed under the following conditions  $V_{dc} = 400$  V, Switching frequency = 1800 Hz, Inverter frequency = 50 Hz,  $V_{ref} = 200$  V. The phase and line voltages of SPWM are shown in Figs. 7 & 8 respectively.

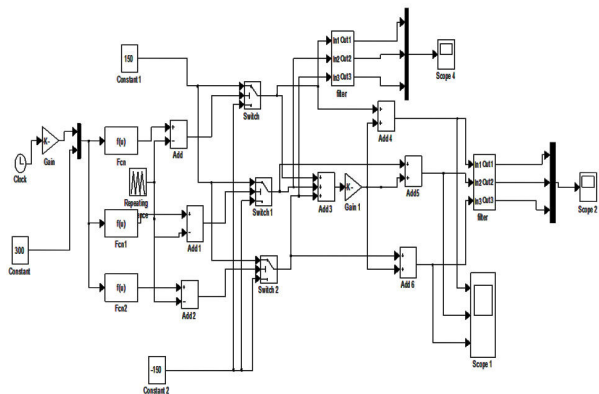

Fig. 6 Simulink model of SPWM

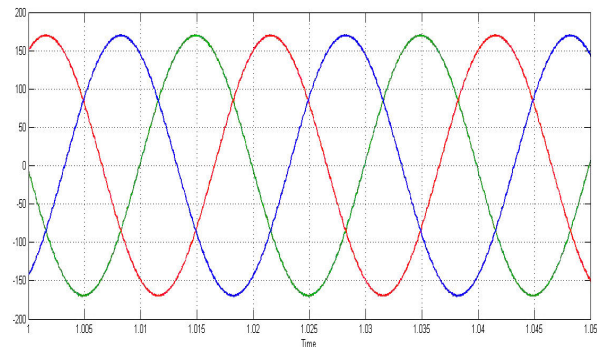

Fig. 7 Phase Voltages of SPWM after filtering

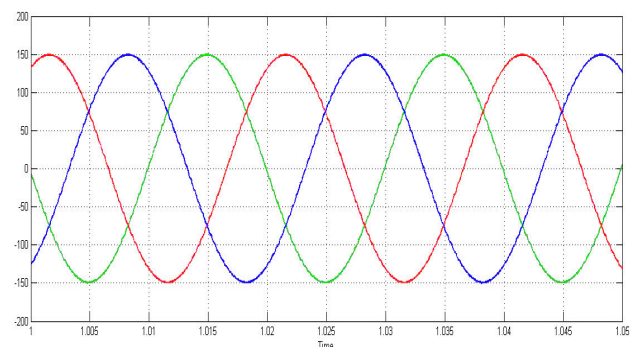

Fig. 8 Line Voltages of SPWM before & after filtering

*B. Space Vector PWM*

The simulink model of svpwm applied to two level inverter is shown in Fig. 9 and the simulink model for generation of

three phase voltage and its output are shown in Figs. 10 & 11 respectively. The inverter output line voltages before and after filtering is shown in Figs. 12 & 13 respectively.

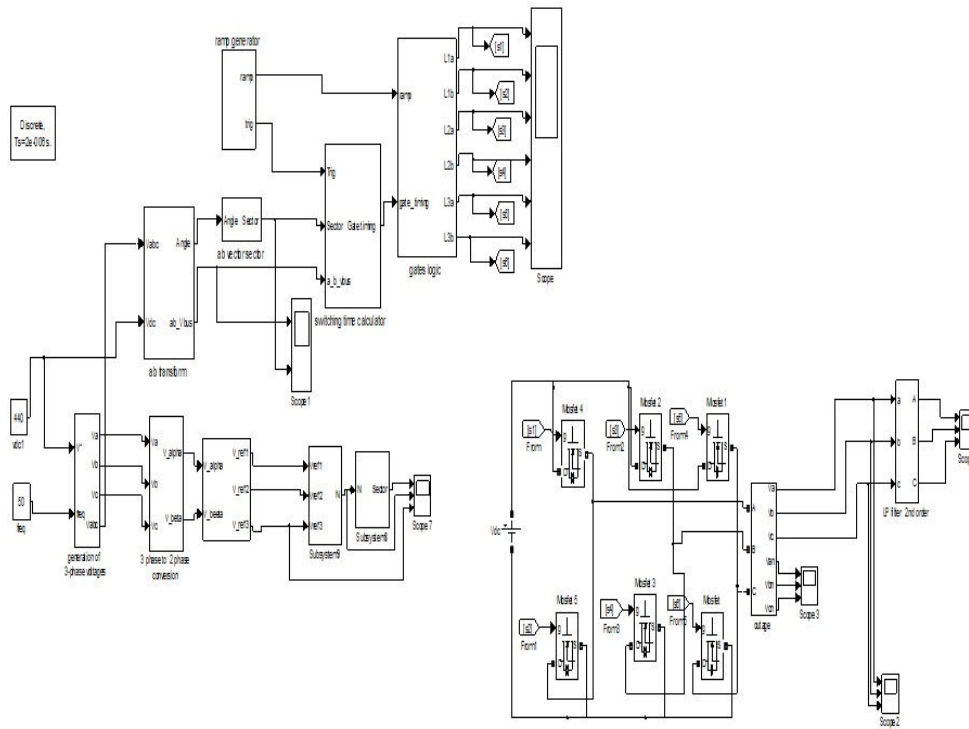

Fig. 9 Simulink model of SVPWM based two level VSI

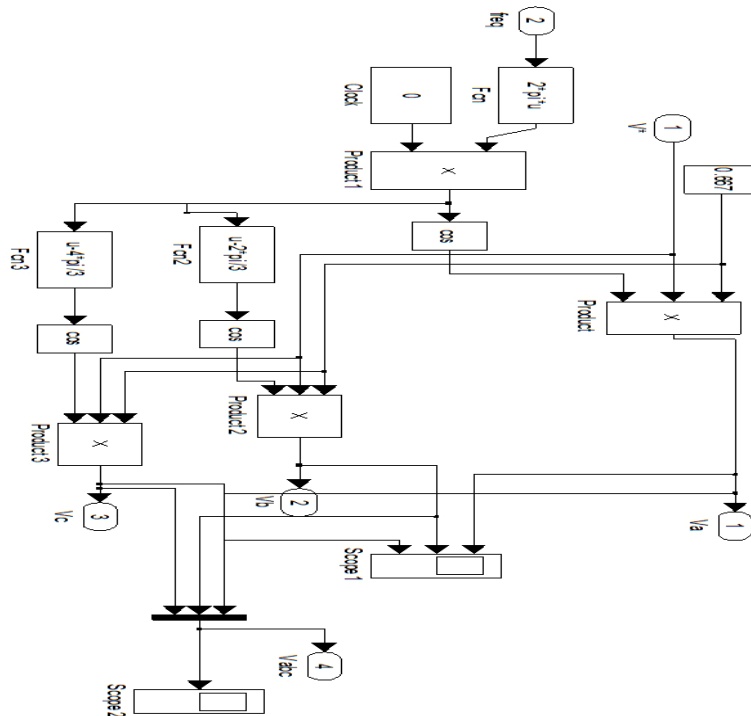

Fig. 10 Simulink diagram for generation of three phase voltages

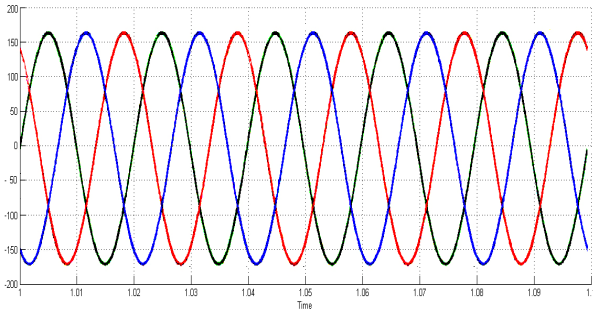

Fig. 11 Generated Three Phase Voltages

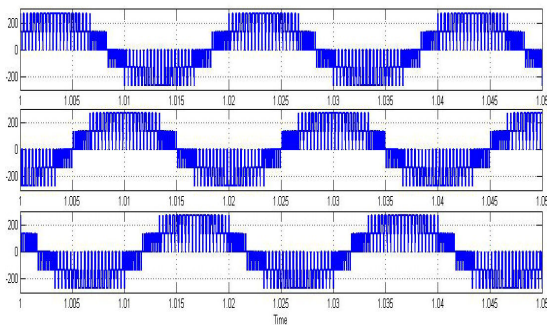

Fig. 12 Output Line Voltages of the inverter before filtering

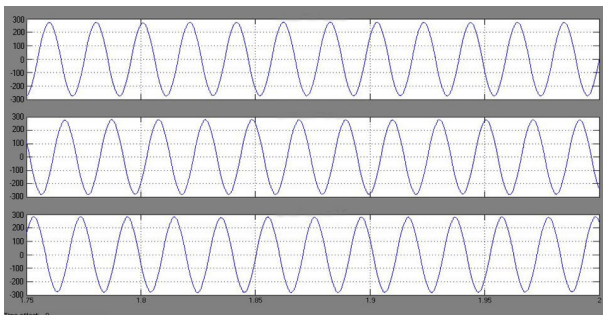

Fig. 13 Line Voltages of the Inverter after filtering

Total harmonic distortion is obtained by using powergui block in simpower systems and is shown in Fig. 14.

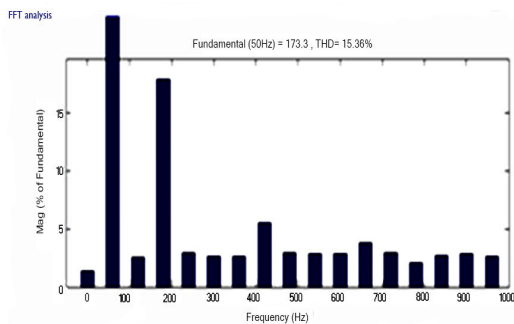

Fig. 14 THD of SVPWM applied to Two Level Inverter

### V.CONCLUSION

This paper has evaluated two different PWM techniques, namely SPWM and SVPWM (in the linear modulation region). The SVPWM technique can only be applied to a three-phase inverter and it increases the overall system efficiency. The SVPWM is used for controlling the switching of the machine side converter. SVPWM research has been widespread in recent years making it one of the most popular methods for three-phase inverters because it has a higher fundamental voltage output than SPWM for the same DC bus voltage. The SVPWM is significantly better than SPWM by approximately 15.5%. However, the SVPWM technique is complex in implementation, especially in the over-modulation region.

### REFERENCES

- [1] Holtz J., "Pulse-width-modulation—a survey", IEEE Transactions on Industrial Electronics, Vol. 39, No. 5, October 1992, pp. 410–419.
- [2] W.F. Zhang and Y.H. Yu, "Comparison of Three SVPWM Strategies," Journal of Electronic Science and Technology of China, Vol. 5, No. 3, September 2007, pp. 283-287.
- [3] Anusha S. and Rama Rao P.V.V., "Performance evaluation of sinusoidal PWM technique for a hybrid multilevel power conversion system", IEEE International Conference on Power Electronics, Drives and Energy Systems (PEDES), December 2012, pp. 1-6.
- [4] Baskys A., Bleizgys V. and Gobis V., "The Impact of Output Voltage Modulation Strategies on Power Losses in Inverter", Elektronika ir Elektrotechnika (Electronics and Electrical Engineering), 2009, No. 6 (94), pp. 47-50.
- [5] Gopinath A., Mohamed A.S.A., and Baiju M.R., "Fractal based space vector PWM for multilevel inverters—a novel approach", IEEE Transactions on Industrial Electronics, Vol. 56, No.4, April 2009, pp. 1230–1237.
- [6] H. Quan, Z. Gang, C. Jie, Z. Wu, and Z. Liu, "Study of A Novel Over-modulation Technique Based on Space-Vector PWM," IEEE International Conference on Computer Distributed Control and Intelligent Environmental Monitoring (CDCIEM), Feb. 2011, pp. 295-298.
- [7] R.K. Pongiannan, Selvabharathi P. and N. Yadaiah, "FPGA Based Three Phase Sinusoidal PWM VVVF Controller," IEEE International Conference on Electrical Energy Systems (ICEES), Jan. 2011, pp. 34-39.
- [8] MathWorks, 2010, SimPowerSystems User's Guide.
- [9] E. Hendawi, F. Khater, and A. Shaltout, "Analysis, Simulation and Implementation of Space Vector Pulse Width Modulation Inverter," 9<sup>th</sup> WSEAS International Conference on Application of Electrical Engineering, March 2010, pp. 124-131.
- [10] K.V. Kumar, P.A. Michael, J.P. John and S.S. Kumar, "Simulation and Comparison of SPWM and SVPWM Control for Three Phase Inverter," Asian Research Publishing Network, Vol. 5, No. 7, July 2010, pp. 61-74.