

Studies on the Mechanical Behavior of Bottom Ash for a Sustainable Environment

B. A. Mir, Asim Malik

Abstract—Bottom ash is a by-product of the combustion process of coal in furnaces in the production of electricity in thermal power plants. In India, about 75% of total power is produced by using pulverized coal. The coal of India has a high ash content which leads to the generation of a huge quantity of bottom ash per year posing the dual problem of environmental pollution and difficulty in disposal. This calls for establishing strategies to use this industry by-product effectively and efficiently. However, its large-scale utilization is possible only in geotechnical applications, either alone or with soil. In the present investigation, bottom ash was collected from National Capital Power Station Dadri, Uttar Pradesh, India. Test samples of bottom ash admixed with 20% clayey soil were prepared and treated with different cement content by weight and subjected to various laboratory tests for assessing its suitability as an engineered construction material. This study has shown that use of 10% cement content is a viable chemical additive to enhance the mechanical properties of bottom ash, which can be used effectively as an engineered construction material in various geotechnical applications. More importantly, it offers an interesting potential for making use of an industrial waste to overcome challenges posed by bottom ash for a sustainable environment.

Keywords—Bottom ash, environmental pollution, solid waste, sustainable environment, waste utilization.

I. INTRODUCTION

In India, coal is used as a major source of power generation, in which bottom ash is the by-product of the combustion of process of coal in furnaces in the production of electricity in thermal power plants. The coal of India has high ash content (30-45%) which leads to the generation of a huge quantity of bottom ash per year, whereas some lignite coals may have an ash content as high as 30% [1]. At present, nearly 150 million tons of coal ash is being generated annually in India, which requires a lot of land area for its disposal and is a major problem from an environmental point of view. Environmentally safe disposal of large quantities of bottom ash is not only tedious and expensive, but also poses challenging problems in the form of land usage, capital loss to power plants, health hazards, ecological imbalances and related environmental problems. Thus, there is a dire need for establishing strategies to use this industrial bi-product effectively and efficiently. Cachim et al. [2] observed that because of increasing environmental concerns and sustainable issues, the utilization of solid waste materials is the need of

the hour. However, it is only in geotechnical engineering applications, such as the construction of embankments/dykes, as back fill material, or as a sub-base material etc., that its large-scale utilization is possible either alone or with soil. On the other hand, the need for industrial wastes such as coal ash produced from power generating plants as a substitute for conventional construction material has increased due to the increased scarcity of stable soil deposits in recent years. The utilization of coal ash not only solves a waste disposal problem but also provides an economically viable construction material [3]. Many researchers have evaluated the characteristics of bottom ash as a substitute for conventional granular material in the literature [4]-[10]. Furthermore, many European countries beneficially utilize bottom ash as a sustainable transportation material with environmental criteria set by their strategic regulations [11]. Sivakumar et al. [12] has concluded that bottom ash can be successfully used as an effective stabilizer for preventing collapses, and the settlement of structures on soft soil deposits. Many other researchers [13]-[18] concluded that bottom ash can successfully used as a granular material to enhance the strength and durability of concrete and to use it as a pozzolanic material.

Bottom ash can generally be classified as coarse grained, in terms of the grain size of soils; while bottom ash particles range in size from fine gravel to fine sand, with low percentages of silt clay-sized particles. Physically, bottom ash is typically grey to black in color, is quite angular, and has a porous surface structure (Fig. 1).



Fig. 1 Bottom ash generated from a thermal power plant

B. A. Mir is among senior faculty with the Department of Civil Engineering, National Institute of Technology Srinagar, Kashmir J&K, India (e-mail: p7mir@nitsri.net, bamiriitb@gmail.com, bashiriisc@yahoo.com).

Asim Malik was the PG Scholar in Geotechnical Engineering Divn. of Department of Civil Engineering, National Institute of Technology Srinagar, Kashmir J&K (e-mail: hasan.asim786@gmail.com).

Pulverized coal combustion dry bottom ash is a type of coal combustion by-product of burning coal under controlled conditions for the generation of electricity. Bottom ash collected under the furnace bottom is categorized as dry

bottom or wet bottom ash. If the ash is in a solid state at the furnace bottom, it is called dry bottom ash, as shown in Fig. 2 [19]. Wet bottom ash refers to the molten state of the ash which leaves the furnace as a liquid. Wet bottom ash is more often called boiler slag. Bottom ash is collected at the bottom of the combustion chamber in a water-filled hopper and is removed by means of high-pressure water jets and conveyed by sluiceways to a decanting basin for dewatering, stockpiling, and possibly crushing. Although similar to natural fine aggregate, bottom ash is lighter and more brittle and has a greater resemblance to cement clinker [20].

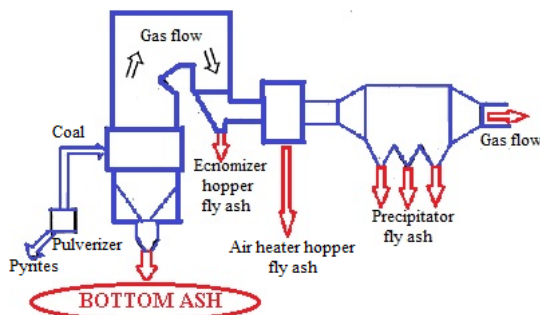

Fig. 2 Schematic diagram of the ash handling system

Bottom ash particles range in size from fine gravel to fine sand, with low percentages of silt clay-sized particles; it is usually a well-graded material, although variations in particle size distribution are possible in bottom ash samples taken from the same power plant at different times. Characteristics of bottom ash also depend on the type of coal burned and the type of furnace used. About half of all produced bottom ash is used in the construction industry, but with different applications, as depicted in Fig. 3 [21]. Fly ash has been mainly used as an additive for the stabilization of problematic soils [22], whereas bottom ash is used in the production of non-aerated concrete blocks and in road construction [23]. Many researchers [24], [25], have reported that coal bottom ash possesses pozzolanic properties, which can enhance the strength activity index of concrete. However, the use of bottom ash, with or without admixtures, in geotechnical engineering applications, and the amount of published literature on the geotechnical engineering properties of bottom ash, is limited. In the present investigation, bottom ash was collected from the National Capital Power Station (NCPS) Dadri, Uttar Pradesh, India. Specimens of bottom ash mixed with 20% clayey soil were treated with varying cement content by weight (0%, 5%, 10%, 15% and 20%) and subjected to various laboratory tests as per standard codal procedures for assessing its suitability as an engineered construction material in geotechnical applications. From the test results, it is observed that 10% of cement content is the optimum amount required to enhance the mechanical properties of bottom ash to be used as an engineered construction material. Therefore, the main objective of the study was to study the mechanical behavior of bottom ash stabilized with cement and bulk utilization of industrial waste

by-product without adversely affecting the environment. Hence, using bottom ash has a two-fold advantage; first, to avoid the tremendous environmental problems caused by large scale dumping of bottom ash, and second, to help in sustainable development of the environment.

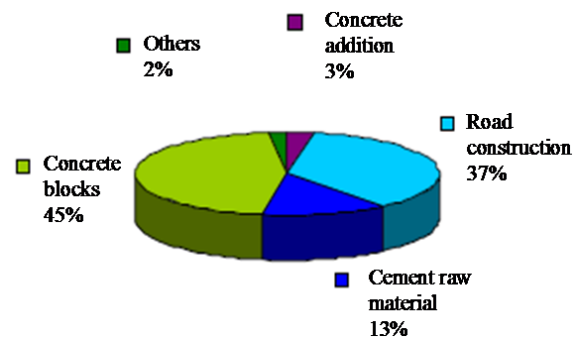

Fig. 3 Utilization of Bottom ash in various applications [21]

II. PROBLEMS ASSOCIATED WITH COAL ASH

There are two types of problems associated with the generation of huge quantities of bottom ash:

1. Environmental problems
2. Land disposal problem

Bottom ash can be disposed-off by two methods, the dry method and wet method. In the dry method, bottom ash is carried out by using trucks etc. and dumped in an open area which leads to wind-swept ash becoming airborne, which creates a lot of health hazards and dust in the environment. In the wet disposal method, bottom ash and fly ash are mixed with water to form slurry and disposed in catchments, which are known as ponds. If the water table is near to the ground surface then there is a chance of contamination of ground water due to the leaching problem.

III. SOLUTION OF DISPOSAL PROBLEMS

Solution to the disposal problem is possible by utilizing bottom ash in civil engineering construction practice. The construction of highways and roads embankments, abutments, earthen dams and other retaining structures requires huge amounts of natural soil and aggregates, and to meet this demand, the widespread exploitation of fertile soil and natural aggregate is being adopted. Due to rapid industrialization and the scarcity of availability of natural soil, scientists have thought to utilize the waste products of power plants as a replacement to the natural soil. This will reduce the scarcity of natural soil and also solve the environmental issues due to the deposition of industrial by-products. When used in structural fills, pavements or embankments (Fig. 4), fly ash and bottom offers several advantages over natural soil or rock. Its relatively low unit weight makes it well suited for placement over soft or low bearing strength soils, and its high shear strength, compared with its unit weight, results in good bearing support and minimal settlement [26], [27]. Geotechnical properties of bottom ash like low specific gravity lower maximum dry density, and higher permeability

leads to its use as a backfill material for retaining structures, because low specific gravity and lower dry density leads to lower levels of earth pressure on retaining walls, which ultimately leads to greater economy in retaining wall construction. In the construction of pavements, it is desirable for the materials have high permeability, which is essential for the quick drainage of water. Hence, the higher permeability of bottom ash makes it suitable for pavement construction as well as for retaining structures.

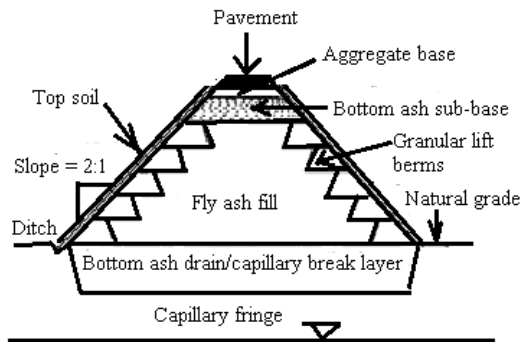

(a) Road embankment

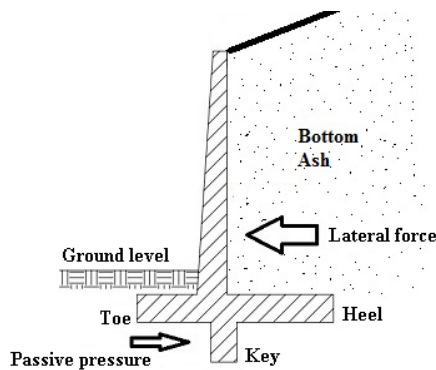

(b) Retaining wall

Fig. 4 Use of Ash in road embankments and retaining walls

IV. MATERIALS AND METHODS

For the present investigation, bottom ash was collected from National Capital Power Station (NCPS) Dadri, U.P.

Clayey soil was collected from the National Institute of Technology Srinagar (NIT), behind the Jhelum hostel, while the cement used in the investigation was of 43 Grade and manufactured by J&K Cements Ltd. Specimens of bottom ash mixed with 20% clayey soil were treated with varying cement content by weight (0%, 5%, 10%, 15% and 20%), and then, Standard Proctor compaction tests and strength tests were carried out on the bottom ash – clayey soil – cement mixes. The specimen mixes were cured for 7 days and 28 days and subjected to direct shear and unconfined compression strength tests. All the samples were prepared as per standard procedures [28] and compacted at $0.95 \gamma_{dmax}$ and optimum moisture content. The physical properties are given in Table I.

TABLE I
PROPERTIES OF BOTTOM ASH, CLAYEY SOIL AND CEMENT

Properties	Bottom Ash	Clayey soil	Properties	Cement
Percentage finer than 75 μ m	26.6	95.82	Grade /Type	43 /OPC
Silt size (%)	26.6	88.32	Specific gravity	3.15
Clay size (%)	0	7.5	Initial setting time	228 min.
Coefficient of uniformity	5.66	6.75	Final setting time	420 min
Coefficient of curvature	2.08	1.40	Density (kg/m ³)	3050
Specific Gravity (G)	1.96	2.60		
Liquid Limit (%)	NP	45.5		
Plasticity Index (%)	NP	23.28		
MDD (kN/m ³)	10.3	16.4		
OMC (%)	41	19		
Cohesion (kPa)	10.8	47.5		
Angle of internal friction (ϕ)	30°	10°		

V. EXPERIMENTAL PROGRAMME

To evaluate the geotechnical properties of bottom ash admixed with clay and cement, the testing program is presented in Table II.

TABLE II
EXPERIMENTAL PROGRAMME FOR BOTTOM ASH- CLAY-CEMNT MIXTURE

Bottom Ash – Clayey soil – Cement Mixes			
Bottom Ash % (G = 1.96)	Clayey Soil % (G = 2.60)	Cement % (G = 3.15)	G _{mix}
80	20	0	2.09
75	20	5	2.15
70	20	10	2.21
65	20	15	2.27
60	20	20	2.33

VI. RESULTS AND DISCUSSION

The main objective of the stabilization is to improve the properties of the bottom ash by adding 20% clay and varying amount of cement. The effect of stabilization on various properties of bottom ash is given below.

A. Effect of Stabilization on Specific Gravity

Specific gravity of bottom ash increases when clayey soil is added to it, and the value of specific gravity further increases with increasing increments of cement content. The specific gravity of bottom ash is very low, 1.96, because of the cenospheres [29] present in it, which takes a lot of space but is very light in weight. The specific gravity of bottom ash was 1.96, and when 20% clayey soil is added, the specific gravity of the composite specimen increased to 2.09, as illustrated in Table II. It is understandable that the increase in specific gravity is due to the addition of heavier particles of clay and cement in the mix samples, which makes the sample well graded and some cenospheres also become filled up by the clay particles.

B. Effect on Compaction Characteristics

The density of soils is an important parameter since it controls its strength, compressibility and permeability. Compaction of soil increases the shear strength and decreases the permeability, compressibility. Compaction is generally

used in the construction of sub-grades of roads and pavements and also in preparing foundation base soil prior to the construction of buildings. Compaction characteristics are a very important property when characterizing any soil sample. The compaction curves [30], [31] for bottom ash admixed with clay and cement mixes are shown in Fig. 5, and the variation of OMC and MDD for bottom ash admixed with 20% clayey soil and varying cement content is shown in Fig. 6.

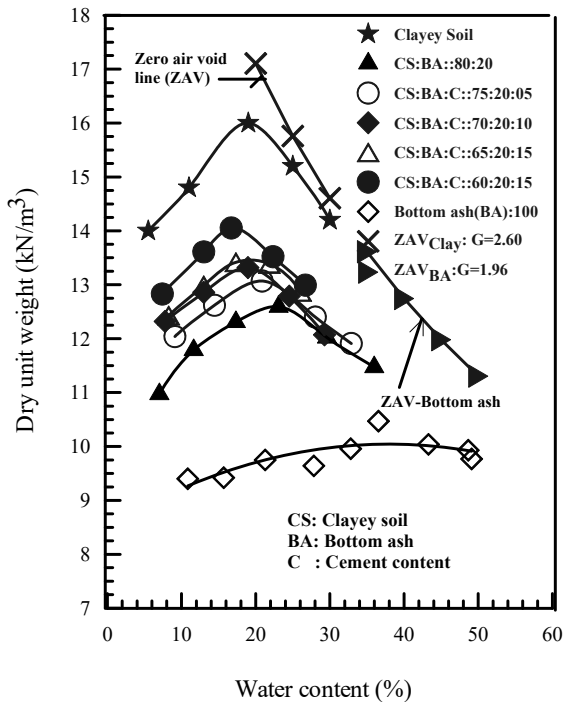

Fig. 5 Compaction curves for bottom ash admixed with clay and cement

From Fig. 5, it is seen that the maximum dry density (MDD) of bottom ash is very low comparatively, and optimum moisture content (OMC) is very high. The reason behind the lower dry density is the large-sized cenospheres (hollow particles) present in the bottom ash which has very low specific gravity; also, the lower dry density is attributed to the poor gradation of bottom ash. The optimum moisture content of bottom ash is very high, this due to the storage of water in the cenospheres and due to the higher surface area of particles. Also, due to poor gradation, some water gets stored in the pores. From Fig. 6, it is seen that OMC of bottom ash samples prepared by mixing clay decreases, the possible reason of this decrease in OMC is that clay particles get inserted in the hollow bottom ash particles and the pores available, due to this quality of poor gradation of bottom ash. OMC further decreases with the increase in cement content due to the increment of fines in the sample which fills the pores of the soil.

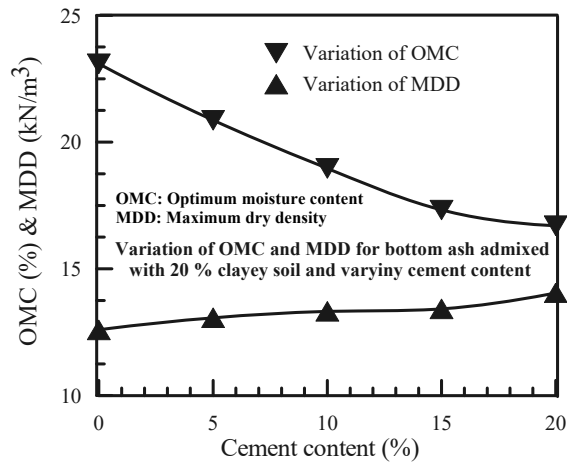

Fig. 6 Variation of OMC and MDD for bottom ash admixed with 20% clayey soil

C. Effect of Stabilization on Strength Behavior of Bottom Ash Admixed with Clay and Cement

For using soil or any other solid waste material (e.g., bottom ash amongst others), either as a construction material or as a foundation material, it is mandatory to investigate their strength characteristics from a stability point of view [32], [33]. In some special cases, such as checking the short-term stability of foundations and slopes where the rate of loading is fast, but drainage is very slow, one of the most common shear tests is the unconfined compression test. The behavior of bottom ash under a load is a measure of its shear strength. Before bottom ash can be used for construction purposes, its shear strength must be determined. In the present study, unconfined compression strength (UCS) test [34] and direct shear test [35] with different cement content were conducted to establish the shear strength parameters as per relevant codal procedures. The tests results for unconfined compression strength tests are shown in Figs. 7 and 8. From Fig. 7, it is seen that unconfined compressive strength of composite samples increases with the increase in cement content due to pozzolanic reaction between cement and the CaO present in the clay and bottom ash. It is also observed that composite samples attain higher durability and that failure strain also increased, which is of great interest for field engineers. This will help in identifying failure patterns, and due to higher failure strain, structures may not fail abruptly. Cement being a mechanical additive, is often used to improve the strength and stiffness of soft clayey soils. From Fig. 8, it is seen that initially, the shear strength of 5% cement admixed bottom ash increases gradually. However, with 10% cement content, the cement per grain contact point increases and, upon hardening, imparts a commensurate amount of bonding at the contact points, which is designated as the active zone. Beyond this zone, there is gradual increase in shear strength with increasing cement content. Similar behavior has also been reported by other researchers, such as Currin et al. [36], [37].

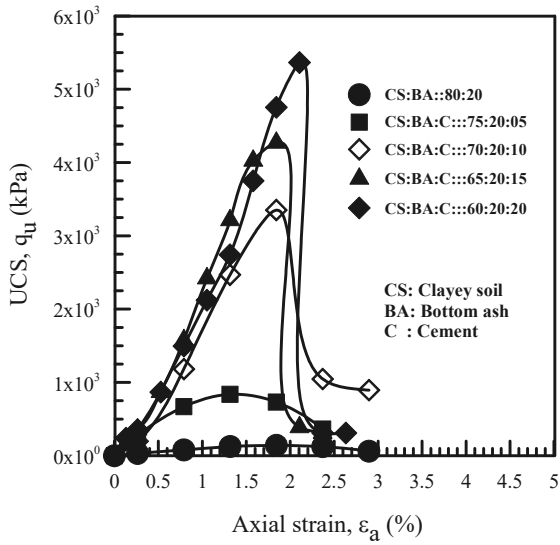

Fig. 7 Stress-strain curve for Bottom ash admixed with clay and cement content

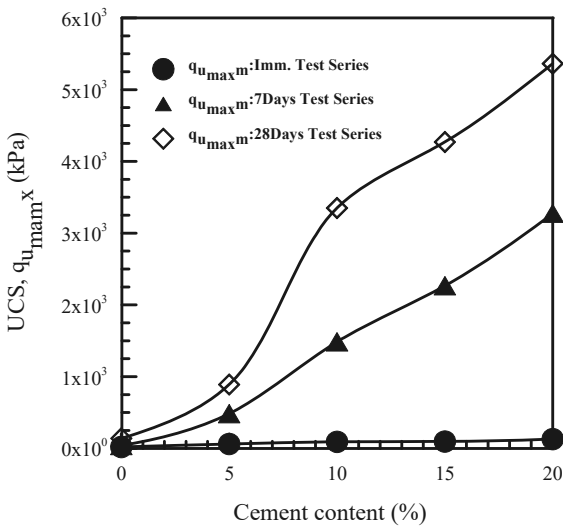
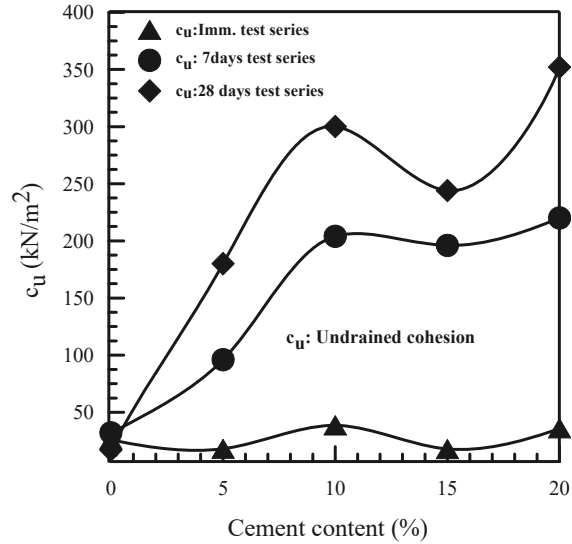

Fig. 8 Variation of $q_{u_{max}}$ for different curing periods

Direct shear tests (DST) were conducted [35] on bottom ash admixed with clayey soil and cement and compacted at $0.95\gamma_{dmax}$ and corresponding water content on dry side of optimum for immediate, 7 days and 28 days curing series tests, respectively. The variation of shear strength parameters with different curing periods is shown in Fig. 9. DST revealed the cohesion value of bottom ash as 10kPa and the angle of internal friction of 30° , which is very low for the use of bottom ash in the applications where loads are of higher magnitude.

The “ c & ϕ ” parameters vary in the range of 10 kN/m^2 to 3000 kN/m^2 and $12-30^\circ$ indicators for bottom ash admixed clayey soil and cement specimens for different curing periods. It is seen from the test results that the value of cohesion intercept increases very rapidly, which is due to the bonding of

particles of bottom ash with cement that is the result of pozzolanic reaction and the angle of internal friction decreasing as cohesion intercept increases. From the all three test series, it is seen that 10% cement content is the optimum cement content for bottom ash to enhance its shear strength parameters and to use it as an engineered construction material in various geotechnical applications for its large scale utilization for sustainable development of the environment.



(a) Variation of undrained cohesion

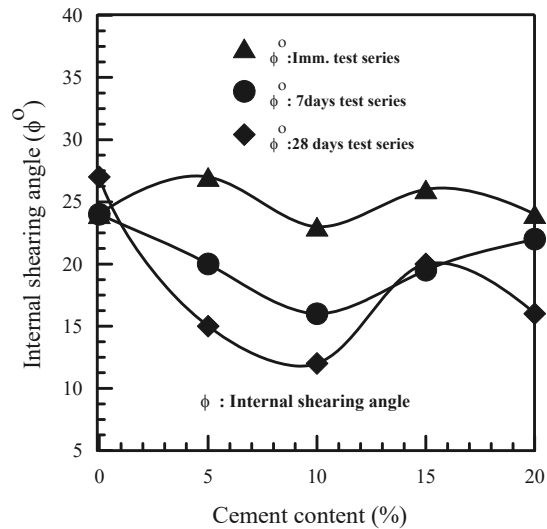

(b) Variation of internal shearing angle

Fig. 9 Variation of cohesion and angle of internal friction with cement content

VII. CONCLUSION

Based on the results of laboratory evaluations of selected bottom ashes, the following conclusions are drawn:

1. It has been shown that bottom ash appears to be suitable for various uses in geotechnical applications as a

- substitute for conventional granular material.
2. Bottom ash is non-plastic material.
 3. Specific gravity of bottom ash is 1.96, which is lower than that of conventional earth material; whereas the specific gravity of sand is found to be 2.65. This low specific gravity is attributed due to presence of cenospheres and poor gradation of bottom ash. However, specific gravity of bottom ash increases with the addition of 20% campus soil and it further increases with increasing increment of cement.
 4. Maximum dry density increases with the addition of clay and cement content. This increase is due to the filling of hollow particles of bottom ash with clay particle and the pores of bottom ash with fine particles of clay.
 5. Unconfined compression strength increases very rapidly at 10% cement content.
 6. Test results of direct shear test show that value of cohesion increases with addition of clay in bottom ash and it further increases with the increase in cement content. This increase in cohesion is due to the bonding of particles by cement.

Thus, the present study brings out the two-fold advantage; first, to avoid the tremendous environmental problems caused by large scale dumping of bottom ash, and second, to help in sustainable development of environment.

ACKNOWLEDGMENT

The investigation reported in this paper forms a part of the research work carried out at National Institute of Technology (NIT) Srinagar, Kashmir (J&K). The support and assistance is gratefully acknowledged. Thanks are due to Faculty of Geotechnical Eng. Division and supporting staff of the Soil Mechanics laboratory and the office staff of Civil Engineering Department for their timely help during the course of investigation. Thanks are also due to National Capital Power Station Dadri, U.P. for providing samples of Bottom ash for this investigation.

REFERENCES

- [1] Mir, B. A., "Effect of fly ash on the engineering properties of black cotton (BC) soils," M. E. Thesis, Dept. of Civil Engineering IISc, Bangalore. 2001.
- [2] Cachim P., Velosa A. L., and Ferraz E., "Substitution materials for sustainable concrete production in Portugal," KSCE Journal of Civil Engineering, 2014; 18(1): pp. 60-66.
- [3] Huang Wei-Hsing, "The use of bottom ash in highway embankments, subgrades, and subbases," Report No. FHWA/IN/JHRP-90/4: HPR Part II, 1990, Purdue University West Lafayette, Indiana 47907.
- [4] Seals R. K., Moulton L. K., and Ruth B. E., "Bottom Ash: An engineering material," Journal of the Soil Mechanics and Foundations Division, ASCE, 1972; 98(SM4): pp. 311-325.
- [5] Idzadeh M, El-Mitiny K. R. N. and Bokowski, G., "Power plant bottom ash in black base and bituminous surfacing" Volume 2, User's Manual, Federal Highway Administration, Report No. FHWA-RD-78-148; 1977, Washington, D.C.
- [6] Miller R. H. and Collins R. J., "Waste materials as potential replacements for highway aggregates," National Cooperative Highway Research' Program Report 166, 1976; Transportation Research Board, Washington, D.C.
- [7] Usmen M. A., Head W. J. and Moulton L. K. "Use of coal-associated wastes in low-volume roads," Transportation Research Record; 1983, 898: pp. 268-277.
- [8] Tyson S. S., "Recent progress in coal ash utilization and the effect of environmental issues and regulations," Disposal and Utilization of Electric Utility Wastes, ASCE, 1988; pp.1-11.
- [9] Moulton L. K. Seals R. K. and Anderson D. A., "Utilization of ash from coal-burning power plants in highway construction," Highway Research Record, 1973; 430: pp.26-39.
- [10] Usmen M. A., "A critical review of the applicability of conventional test methods and materials specifications to the use of coal-associated wastes in pavement construction," Ph.D. Dissertation, West Virginia University, Morgantown, WV, 1977.
- [11] Juergen Vehlow, "Waste-to-energy ash management in Europe," Encyclopedia of Sustainability Science and Technology. Springer, 2012: 883, NY.
- [12] Sivakumar D. Ammaippan M., Anand R. and Lavanya V., "Importance of bottom ash in preventing soil failure," Journal of Chemical & Pharmaceutical Sciences, 2015; 8(4): pp.836-840.
- [13] Singh M., "Effect of coal bottom ash on strength and durability properties of concrete," Ph.D. Thesis, Department of civil engineering Thapar University, Patiala-147004, Punjab, 2015.
- [14] Malik, A., "Bottom ash- as an engineered construction material for sustainable environment," Master's Dissertation, Deptt. of Civil Engineering, NIT Srinagar, India, 2016.
- [15] Rubner K., Haamkens F. and Linde O., "Use of municipal solid waste incinerator bottom ash as aggregate in Concrete," Quarterly Journal of Engineering Geology and Hydrogeology, 2008, 41(4), pp.459-464.
- [16] Cheng An., "Effect of incinerator bottom ash properties on mechanical and pore size of blended cement mortars," Materials & Design, 2012, 36(0), pp. 859-864.
- [17] Ginés O., Chimenos J. M., Vizcarro A., Formosa J. and Rosell J. R., "Combined use of MSWI bottom ash and fly ash as aggregate in concrete formulation: Environmental and Mechanical Considerations," Journal of Hazardous Materials, 2009, 169(1-3), pp. 643-650.
- [18] Kurama H. and Kaya M., "Usage of coal combustion bottom ash in concrete mixture." Construction and Building Materials, 2008, Vol. 22, pp. 1922-1928.
- [19] Moulton L. K., "Bottom ash and boiler slag," Third International Ash utilization Pittsburgh, PA, Bureau of Mines, 1973; Circular 8640: pp. 148-169.
- [20] Rogbeck J. and Knutz A., "Coal bottom ash as light fill material in construction," Waste Management, 1996; 16(1-3): pp.125-8.
- [21] ECO07, "European Coal Combustion Products Association," ECOBA. Production and Utilization of CCPs in Europe, 2007.
- [22] Mir B. A. and Pandian N. S., "Fly ash-as an additive for stabilization of soils," International Workshop and Conference on Construction and Materials (CONMAT-2003), IIT Khargpur, 2003; pp. 739-750.
- [23] Martins I. M., Gonçalves A. and Marques J. C., "Durability and strength properties of concrete containing coal bottom ash," International RILEM Conference on Material Science, 2010; Aachen. RILEM Publications SARL (9): pp. 275 – 283.
- [24] Cherif M., Cavalcante R. J. and Péra J., "Pozzolanic properties of pulverized coal combustion bottom ash," Cement and Concrete Research, 1999; 29(9): pp. 1387-1391.
- [25] Jaturapitakkul C. and Cheearot R., "Development of bottom ash as pozzolanic material," Journal of Materials in Civil Engineering, 2003; 15(1): pp.48-53.
- [26] Kim B., Prezzi M. and Salgado R., "Geotechnical properties of fly and bottom ash mixtures for use in highway embankments," Journal of geotechnical and geoenvironmental engineering, 2005; ASCE, pp. 914 - 924.
- [27] Mir B. A., "Effect of fly ash and lime on some physical and mechanical properties of expansive clay," International Journal of Civil Engineering, 2015; Transaction B 13(3&4B): pp. 203-212.
- [28] IS: 2720-part 1, "Indian standard code for preparation of soil samples," Bureau of Indian Standards (BIS), New Delhi, 1980.
- [29] Pandian N. S., Rajasekhar C. and Sridharan A., "Studies of the specific gravity of some Indian coal ashes," JI. of testing and evaluation, JTEA, 1998; 26(3): pp. 177- 186.
- [30] IS: 2720-part 7, "Determination of water content-dry density relation using light compaction," Bureau of Indian Standards (BIS), New Delhi, 1980.
- [31] IS: 2720-part 8, "Determination of water content-dry density relation using heavy compaction," Bureau of Indian Standards (BIS), New Delhi, 1980.
- [32] Mir B. A. and Pandian N. S., "Effect of fly ash on the unconfined

- compressive strength of BC soil,” Procc. IGC-2004: Ground Engineering - Emerging Techniques-(GREET), 2004, Vol. 1, Theme-3, pp. 137-140.
- [33] Pandian N. S., Sridharan A. and Chitibabu G., “Shear strength of coal ashes for geotechnical applications,” The new Millennium Conference-2001, IGC-Indore, Vol. 1, pp. 466-469.
- [34] IS: 2720-part 10 (1973) “Determination of shear strength parameter by unconfined compression test,” BIS, New Delhi.
- [35] IS: 2720-part 39, “Determination of shear strength parameter by direct shear test,” Bureau of Indian Standards (BIS), New Delhi, 1977.
- [36] Currin D. D., Allen J. J., and Little D. N., “Validation of soil stabilization index system with manual development,” Report No. FJSRL-TR-0006, Frank J. Seisler Research Laboratory, United States Air Force Academy, Colorado, 1976.
- [37] Alhassan H. M and Tanko A. M., “Characterization of solid waste incinerator bottom ash and the potential for its use,” International Journal of Engineering Research and Applications, 2012, 2(4), pp. 516-522.



B. A. Mir (Proffessor) is Corresponding Author of this paper (e-mail: p7mir@nitsri.net).

The main emphasis of this paper is to investigate the suitability of bottom ash as an engineered construction material and to avoid the tremendous environmental problems caused by large scale dumping of bottom ash and to help in sustainable development of environment by its bulk utilization in various Geotechnical applications.