

# Steady-State Analysis and Control of Double Feed Induction Motor

H. Sediki, Dj. Ould Abdeslam, T. Otmane-cherif, A. Bechouche, K. Mesbah

**Abstract**—This paper explores steady-state characteristics of grid-connected doubly fed induction motor (DFIM) in case of unity power factor operation. Based on the synchronized mathematical model, analytic determination of the control laws is presented and illustrated by various figures to understand the effect of the applied rotor voltage on the speed and the active power. On other hand, unlike previous works where the stator resistance was neglected, in this work, stator resistance is included such that the equations can be applied to small wind turbine generators which are becoming more popular. Finally the work is crowned by integration of the studied induction generator in a wind system where an open loop control is proposed confers a remarkable simplicity of implementation compared to the known methods.

**Keywords**—DFIM, equivalent circuit, induction machine, steady state

## I. INTRODUCTION

**D**URING the last years the induction machine is the most used to produce electrical energy in wind power projects. A common configuration for large wind turbines is based on doubly fed induction generator (DFIG) with back to back converter between the AC grid and the rotor winding. The mean advantage of the DFIG is the ability of variable speed operation with only 20-30% of the generated power having to pass through the power converter. This yield considerable reduction in the converter size which translates to substantial system cost benefit. Therefore, the power extraction from the wind can be optimized since the rotating speed can be changed proportionally to the wind speed. Many control strategies of the DFIG have been proposed in the literature. Most are based on the transient state model of the machine and leads to an adequate control of the active and reactive power [1]-[2]. The methods intended to the control remains complex if no simplification are made in the transient model and do not contribute to understand how the DFIM operates.

Useful analytical methods for the determination of steady state control laws have also been presented. The most are usually performed using nonlinear constrained optimization routine [3] - [4]. Many authors show that is possible to drive analytical solution from the steady state model in term of rotor voltage and control angle on the whole speed range operation [5]-[6]. But in the proposed approaches it is assumed that the mechanical loss and the stator resistance are neglected.

H. Sediki , T. Otmane-cherif, A. Bechouche and K. Mesbah are with the Department of Electrical Engineering, Mouloud Mammeri University, BP 17 RPTizi-Ouzou, Algeria(e-mail: sedikihamid2004@yahoo.fr; otmane\_cherif@yahoo.com,ali\_bechouche@yahoo.fr;mesbahkousseila@yahoo.fr;

DJ. Ould Abdeslam is with the MIPS Laboratory, University of Haute Alsace, 4 rue des Frères Lumières, F-68093 Mulhouse, France (e-mail : djaffar.ould-abdeslam@uha.fr).

Furthermore, many authors was examined the Stability of the DFIM by considering only the steady state model [7].

In this paper, we present a detailed analysis of the overall performance of the DFIG operating at the steady state and in the case of unity power factor. Stator resistance is included such that the equations can be applied to small wind turbine generators. This research of the steady state characteristics is useful to understand the DFIM behaviors in a broader spectrum. Especially it shows how the speed and electromagnetic torque are affected by the injected rotor voltage. Moreover results obtained from the stationary analysis can allow initializing electrical variable in the dynamic models. This study can be used as a basis to analyze this generator and shed more light on the operation points.

This work includes appropriate way to find the limit quantities and safety areas, according to the applied rotor voltages and the slip, ensuring safety operation of the machine.

At the end, analytical expressions, derived from the steady state model, are given and which lead to an easy open loop control of the DFIM. The proposed control doesn't need any sensors but ensure a zero reactive power.

The equivalent circuit is obtained from the conventional  $dq$  stator and rotor equations. The steady state equations describing the model of the DFIM are function of three independent variables. These are: the speed of the generator which is introduced through the slip, the two rotor excitation voltages components. All the quantities are referred to the stator voltage.

This paper is organized as follow:

- Section II gives a methodology which leads to the used DFIM equivalent circuit.
- Section III deals with the different characteristics of the DFIM under unity power factor operation.
- Section IV defines the safety operation area according to slip, rotor voltage and the acceptable maximal current.
- Section V presents an open loop control of the DFIM so easy to implement, without any sensors and ensuring unity power factor operation.
- The conclusion of this study is given in section VI.

## II. STEADY STATE DFIM MODELS

### A. Dynamic Equations of DFIM

The DFIM consist of a wound rotor induction machine connected to a converter. The stator is supplied by the grid so that the rotor's side frequency superimposed with the rotor speed result a synchronously rotating field. Only the fundamental components of the voltage and currents are considered for stator and rotor. Core losses are neglected in the general analysis.

Using the  $dq$  reference frame, the general full order dynamic model of DFIM is given by:

$$V_{sd} = R_s I_{sd} + \frac{d\phi_{sd}}{dt} - \omega_s \phi_{sq} \quad (1)$$

$$V_{sq} = R_s I_{sq} + \frac{d\phi_{sq}}{dt} + \omega_s \phi_{sd} \quad (2)$$

$$V_{rd} = R_r I_{rd} + \frac{d\phi_{rd}}{dt} - \omega_r \phi_{rq} \quad (3)$$

$$V_{rq} = R_r I_{rq} + \frac{d\phi_{rq}}{dt} + \omega_r \phi_{rd} \quad (4)$$

The rotor and stator fluxes are related to the current by:

$$\phi_{sd} = L_s I_{sd} + L_m I_{rd} \quad (5)$$

$$\phi_{sq} = L_s I_{sq} + L_m I_{rq} \quad (6)$$

$$\phi_{rd} = L_r I_{rd} + L_m I_{sd} \quad (7)$$

$$\phi_{rq} = L_r I_{rq} + L_m I_{sq} \quad (8)$$

The electromagnetic torque  $\Gamma_e$  can be expressed according to the stator flux and rotor current by:

$$\Gamma_e = p \frac{L_m}{L_s} (I_{rq} \phi_{sd} - I_{rd} \phi_{sq}) \quad (9)$$

The variation of the mechanical speed is given by the following differential equation:

$$\Gamma_e = J \frac{d\Omega}{dt} + f\Omega + \Gamma_l \quad (10)$$

### B. Steady State Equations of DFIM

The steady state equations of the DFIM are obtained by cancelling the time derivatives in the dynamic equations (1) to (4). Moreover, by replacing the different flux by their respective equations given according to the stator and rotor currents, we obtain:

$$V_{sd} = R_s I_{sd} - L_s \omega_s I_{sq} - L_m \omega_s I_{rq} \quad (11)$$

$$V_{sq} = R_s I_{sq} + L_s \omega_s I_{sd} + L_m \omega_s I_{rd} \quad (12)$$

$$V_{rd} = R_r I_{rd} - L_r \omega_r I_{rq} - L_m \omega_r I_{sq} \quad (13)$$

$$V_{rq} = R_r I_{rq} + L_r \omega_r I_{rd} + L_m \omega_r I_{sd} \quad (14)$$

The four equations (11) to (14) can be reduced to two: one at the rotor and another at the stator by introducing the voltages and currents space vectors  $\bar{V}_s, \bar{V}_r, \bar{I}_s$  and  $\bar{I}_r$  defined by:

$$\bar{V}_s = V_{sd} + jV_{sq} \quad (15)$$

$$\bar{V}_r = V_{rd} + jV_{rq} \quad (16)$$

$$\bar{I}_s = I_{sd} + jI_{sq} \quad (17)$$

$$\bar{I}_r = I_{rd} + jI_{rq} \quad (18)$$

By noting:

$$X_s = L_s \omega_s \quad (19)$$

$$X_r = L_r \omega_r \quad (20)$$

$$X_m = L_m \omega_s \quad (21)$$

$$\omega_r = s\omega_s \quad (22)$$

Easy intermediate calculations makes possible to lead to two equations, one at the stator and the other at the rotor, which determinate the steady state operation of the DFIM. These two equations are given by:

$$\bar{V}_s = (R_s + jX_s) \bar{I}_s + jX_m \bar{I}_r \quad (23)$$

$$\frac{\bar{V}_r}{s} = jX_m \bar{I}_s + \left( \frac{R_r}{s} + jX_r \right) \bar{I}_r \quad (24)$$

In matrix form we got:

$$\begin{bmatrix} \bar{V}_s \\ \frac{\bar{V}_r}{s} \end{bmatrix} = \begin{bmatrix} R_s + jX_s & jX_m \\ jX_m & \frac{R_r}{s} + jX_r \end{bmatrix} \begin{bmatrix} \bar{I}_s \\ \bar{I}_r \end{bmatrix} \quad (25)$$

The equations (23) and (24) can be translated in equivalent circuit called: transformer equivalent circuit of DFIM given by Fig. 1.

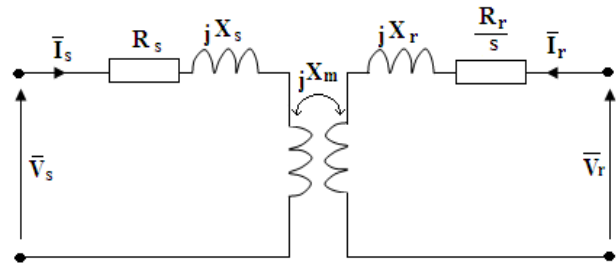

Fig. 1 Transformer equivalent circuit of DFIM

The equivalent circuit of Fig. 1 is rarely used in the literature. It is preferable to adopt the equivalent circuit where all the sizes are referred to the stator. This representation would be obtained by introducing on the rotor quantities the transformation ratio defined by:  $a = X_s / X_m$

Then we pose:

$$\bar{V}_r = a\bar{V}_r' : \text{Rotor voltage referred to the stator.}$$

$$\bar{I}_r = \bar{I}_r' / a : \text{Rotor current referred to the stator.}$$

By introducing this variable changes into (23) and (24) it gives:

$$\bar{V}_s = R_s \bar{I}_s + jX_s (\bar{I}_s + \bar{I}_r') \quad (26)$$

$$\frac{\bar{V}_r'}{s} = \frac{R_r'}{s} \bar{I}_r' + jX_r' \bar{I}_r' + jX_s (\bar{I}_s + \bar{I}_r') \quad (27)$$

With:

$X'_\sigma = a^2 \sigma X_r$  : Leakage Reactance referred to the stator

$R'_r = a^2 R_r$  : Rotor resistance referred to the stator

The equations (26) and (27) can be written in the following matrix form:

$$\begin{bmatrix} \bar{V}_s \\ \bar{V}_r \\ s \end{bmatrix} = \begin{bmatrix} R_s + jX_s & jX_s \\ jX_s & \frac{R'_r}{s} + jX_s + jX'_\sigma \end{bmatrix} \begin{bmatrix} \bar{I}_s \\ \bar{I}_r \end{bmatrix} \quad (28)$$

Then it possible to lead to an equivalent circuit which differs from the induction machine conventional circuit by the presence of the rotor voltage  $\bar{V}'_r/s$ :

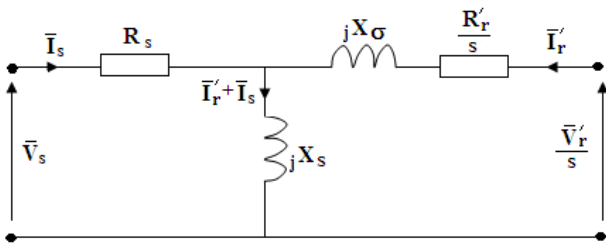

Fig. 2 Equivalent circuit of DFIG referred to the stator side

### C. Analytical Expressions of $\bar{I}_s$ and $\bar{I}_r$

To find the expressions of the stator and rotor currents,  $\bar{I}_s$  and  $\bar{I}_r$ , according to the voltages and the slip, it would be easier to apply the theorem of superposition. The  $\bar{I}_s$  current will be the superposition of two currents  $\bar{I}_{1s}$  and  $\bar{I}_{2s}$  which are respectively created by the source  $\bar{V}_s$  with  $\bar{V}'_r/s$  null and by the source  $\bar{V}'_r/s$  while keeping  $\bar{V}_s$  null. The same procedure will be applied to the current  $\bar{I}_r$ .

#### 1. $\bar{I}_{1s}$ and $\bar{I}_{1r}$ Computation

By shorting-circuit the rotor side source  $\bar{V}'_r$ , one leads to the equivalent diagram of Fig. 3.

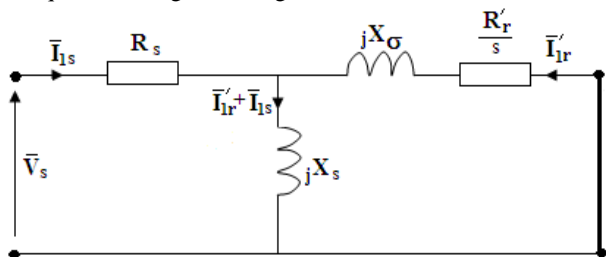

Fig. 3 Superposed theorem applied to the equivalent circuit for  $\bar{I}_{2s}$  and  $\bar{I}_{2r}$  computation

From Fig. 3 it is easy to write:

$$\begin{aligned} \bar{I}_{1s} &= \frac{\bar{V}_s}{R_s + (jX_s // (R'_r/s + jX'_\sigma))} \\ &= \frac{R'_r + jsX_s + jsX'_\sigma}{sX_s^2 + (R_s + jX_s)(R'_r + jsX'_\sigma + jsX_s)} \bar{V}_s \end{aligned} \quad (29)$$

$$\begin{aligned} \bar{I}_{1r} &= -\frac{jX_s // (R'_r/s + jX'_\sigma)}{R'_r/s + jX'_\sigma} \bar{I}_{1s} \\ &= \frac{-jsX_s}{sX_s^2 + (R_s + jX_s)(R'_r + jsX'_\sigma + jsX_s)} \bar{V}_s \end{aligned} \quad (30)$$

#### 2. $\bar{I}_{2s}$ and $\bar{I}_{2r}$ Computation

By short-circuiting the stator side source  $\bar{V}_s$ , one leads to the equivalent diagram of Fig. 4.

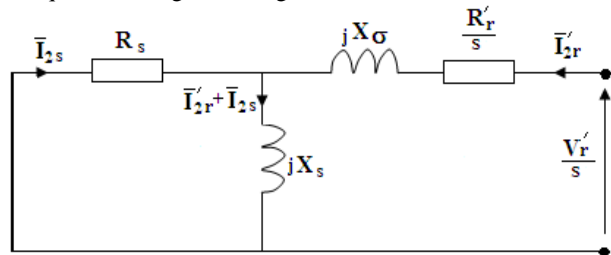

Fig. 4 Superposed theorem applied to the equivalent circuit for  $\bar{I}_{2s}$  and  $\bar{I}_{2r}$  computation

By using fig. 4, it can be easily deduced that:

$$\begin{aligned} \bar{I}_{2r} &= \frac{\bar{V}'_r/s}{(R'_r/s + jX'_\sigma) + (R_s // jX_s)} \\ &= \frac{(sR_s + jsX_s)}{sX_s^2 + (R_s + jX_s)(R'_r + jsX'_\sigma + jsX_s)} \frac{\bar{V}'_r}{s} \end{aligned} \quad (31)$$

$$\begin{aligned} \bar{I}_{2s} &= -\frac{R_s // jX_s}{R_s} \bar{I}_{2r} \\ &= \frac{-jsX_s}{sX_s^2 + (R_s + jX_s)(R'_r + jsX'_\sigma + jsX_s)} \frac{\bar{V}'_r}{s} \end{aligned} \quad (32)$$

Finally the currents  $\bar{I}_s$  and  $\bar{I}_r$  are given by the following expressions:

$$\bar{I}_s = \bar{I}_{1s} + \bar{I}_{2s} = \frac{(R'_r + jsX_s + jsX'_\sigma)\bar{V}_s - jX_s\bar{V}'_r}{sX_s^2 + (R_s + jX_s)(R'_r + jsX'_\sigma + jsX_s)} \quad (33)$$

$$\bar{I}_r = \bar{I}_{1r} + \bar{I}_{2r} = \frac{-jsX_s\bar{V}_s + (R_s + jX_s)\bar{V}'_r}{sX_s^2 + (R_s + jX_s)(R'_r + jsX'_\sigma + jsX_s)} \quad (34)$$

### 3. Modified Equivalent Circuit of the DFIM

The equivalent diagram of Fig. 3 can be modified, to become more realistic, by giving a physical interpretation for the fictitious source  $\bar{V}_r/s$ , fictitious resistance  $R'_r/s$  and by reasoning on the power having to pass through the rotor.

According to the equivalent circuit of Fig. 2, we can conclude that the electromagnetic power  $P_e$ , transmitted to the stator, is equal to the active power provided by the  $\bar{V}_r/s$  source minus the joule losses dissipated in the fictitious resistance  $R'_r/s$ :

$$P_e = \operatorname{Re}\left(\frac{\bar{V}_r}{s} \bar{I}_r^*\right) - \frac{R'_r}{s} |I_r'|^2 \quad (35)$$

On other hand, the electromagnetic power  $P_e$  is the sum of three active power  $P_r$ , provided by the real source  $\bar{V}_r$ , plus the mechanical power  $P_m$  minus the Joule losses dissipated in the real resistance  $R'_r$ :

$$P_e = \operatorname{Re}(\bar{V}_r \bar{I}_r^*) + P_m - R'_r |I_r'|^2 \quad (36)$$

Making member to member the equality between (35) and (36), we lead to the following mechanical power expression:

$$P_m = \frac{1-s}{s} \operatorname{Re}(\bar{V}_r \bar{I}_r^*) - \frac{1-s}{s} R'_r |I_r'|^2 = \frac{1-s}{s} (P_r - R'_r |I_r'|^2) \quad (37)$$

It can be seen according (37) that the mechanical power  $P_m$  is made up of two terms: the first term,  $(1-s)P_r/s$  is part of the active power provided by the source  $\bar{V}_r$  which converted into mechanical power. The second term  $-(1-s)R'_r |I_r'|^2/s$  represents the mechanical power provided from the outside. By taking account of the losses in the resistance  $R'_r$ , we lead finally to the modified equivalent circuit shown at Fig. 5:

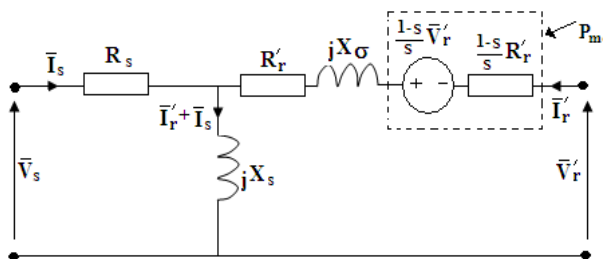

Fig. 5 Modified equivalent circuit of the DFIM

### III. CHARACTERISTICS OF THE DFIM IN THE CASE OF UNITY POWER FACTOR OPERATION

The rotor of a DFIM is generally supplied by a PWM inverter. The DC bus voltage is maintained constant by an adequate control of a PWM rectifier which is fed by the grid

via a three-phase transformer. Moreover, the control of the grid side rectifier ensures a unity power factor so that the rotor side reactive power can be considered as null. The DFIM reactive power  $Q_{gen}$  is defined as only that passing through the stator.

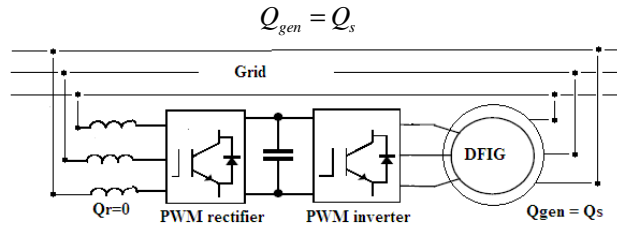

Fig. 6 DFIM connected to the grid

#### A. Stator Reactive Power Characteristics

The reactive power  $Q_s$  swapped between the stator and the grid is given by the following relation:

$$Q_s = \operatorname{Im}(\bar{V}_s \bar{I}_s^*) \quad (38)$$

By taking the stator voltage vector  $\bar{V}_s$  as origin of the phases we are able to write  $\bar{V}_s = V_{sd} + jV_{sq} = V_{sd} = V_s$ , moreover, by substituting the current  $\bar{I}_s$  given by (33) the reactive power  $Q_s$  is given by:

$$Q_s = V_s \operatorname{Im}(\bar{I}_s^*) = V_s \left[ \frac{(R'_r V_s + V'_{rq} X_s)(sR'_s X'_\sigma + sR'_s X_s + R'_r X_s)}{(sR'_s X'_\sigma + sR'_s X_s + R'_r X_s)^2 + (R'_r R'_s - sX_s X'_\sigma)^2} - \frac{(sV_s X'_\sigma + sV_s X_s - V'_{rd} X_s)(R'_r R'_s - sX_s X'_\sigma)}{(sR'_s X'_\sigma + sR'_s X_s + R'_r X_s)^2 + (R'_r R'_s - sX_s X'_\sigma)^2} \right] \quad (39)$$

To have  $Q_s$  constantly null, the following equality should be satisfied:

$$\left[ (R'_r V_s + V'_{rq} X_s)(sR'_s X'_\sigma + sR'_s X_s + R'_r X_s) - (sV_s X'_\sigma + sV_s X_s - V'_{rd} X_s)(R'_r R'_s - sX_s X'_\sigma) \right] = 0 \quad (40)$$

From (40) we deduce that if we want to operate at zero reactive power, the rotor voltage component  $V'_{rq}$  must be calculated according  $V'_{rd}$  by the following relation:

$$V'_{rq} = \frac{(sV_s X'_\sigma + sV_s X_s - V'_{rd} X_s)(R'_r R'_s - sX_s X'_\sigma)}{X_s (sR'_s X'_\sigma + sR'_s X_s + R'_r X_s)} - \frac{R'_r V_s}{X_s} \quad (41)$$

Fig. 7 shows the DFIM rotor voltage  $V'_{rq}$  against the slip  $s$  as variation in  $V'_{rd}$ . Note that the operating characteristics ensure a zero reactive power at the stator side.

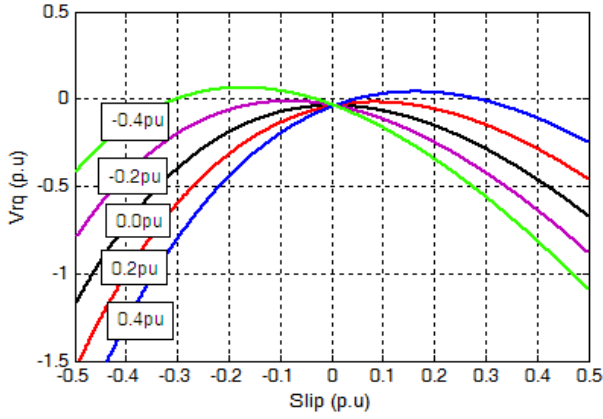
 Fig. 7  $V'_{rq}$  component versus slip for different value of  $V'_{rd}$ 

### B. Stator Current Characteristics

By supposing the reactive power equal to zero, it results:

$$Q_s = \text{Im}(\bar{V}_s \bar{I}_s^*) = V_s \text{Im}(I_{sd} - jI_{sq}) = 0 \Rightarrow I_{sq} = 0 \quad (42)$$

It is deduced that the stator current does not have an imaginary component; the space vector  $\bar{I}_s$  merges with the real component  $I_{sd}$ :

$$\bar{I}_s = I_{sd} = I_s \quad (43)$$

By using the relation given by (33) combined with the fundamental relation of (40) we find that the current  $\bar{I}_s$  is given by:

$$I_s = \frac{sV_s X'_\sigma + sV_s X_s - V'_{rd} X_s}{sR_s X'_\sigma + sR_s X_s + R_r X_s} \quad (44)$$

The active power  $P_s$  passing through the stator is given by the following relation:

$$P_s = \text{Re}(\bar{V}_s \bar{I}_s^*) = V_s I_s \quad (45)$$

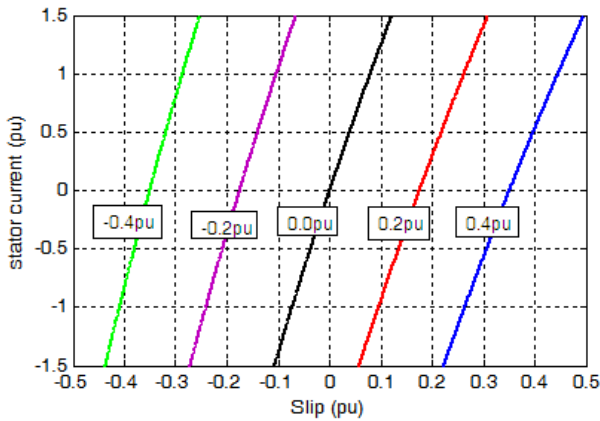

 Fig. 8  $|I_s|$  versus slip for different value of  $V'_{rd}$ 

Fig. 8 shows the stator current with respect to the slip as  $V'_{rd}$  increases from -0.4p.u to 0.4p.u. Note that characteristics have a line forms when  $I_s$  not exceed the rated current. It is possible to give an explanation if the resistance is made equal to zero in (44):

$$I_s = \frac{V_s (X'_\sigma + X_s)}{R_r X_s} s - \frac{V'_{rd}}{R_r} \quad (46)$$

The characteristics have a constant slop  $V_s (X'_\sigma + X_s) / R_r X_s$  with a minor influence of the  $V'_{rd} / R_r$  term.

### C. Rotor Current Characteristics

The rotor current  $\bar{I}_r$ , with the adopted Conventions, is the difference between the magnetizing current  $\bar{I}_m$  passing through  $X_s$  and the stator current:

$$\bar{I}_r = \frac{V_s - R_s I_s}{jX_s} - I_s = j \frac{R_s I_s - V_s}{X_s} - I_s = I'_{rd} + jI'_{rq} \quad (47)$$

With:

$$I'_{rd} = -I_s = -\frac{sV_s X'_\sigma + sV_s X_s - V'_{rd} X_s}{sR_s X'_\sigma + sR_s X_s + R_r X_s} \quad (48)$$

$$I'_{rq} = \frac{R_s I_s - V_s}{X_s} = \frac{R_s}{X_s} \frac{sV_s X'_\sigma + sV_s X_s - V'_{rd} X_s}{sR_s X'_\sigma + sR_s X_s + R_r X_s} - \frac{V_s}{X_s} \quad (49)$$

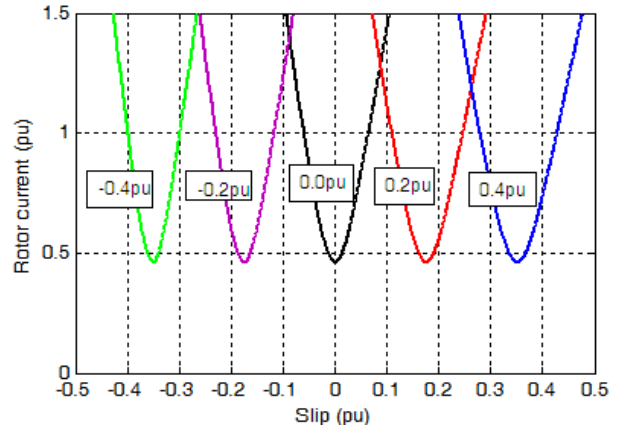

 Fig. 9  $|I'_r|$  versus slip for different value of  $V'_{rd}$ 

Fig. 9 shows the modulus of the rotor current versus the slip as  $V'_{rd}$  increases from -0.4p.u to 0.4p.u. It is noted that the current is still different of zero because of the needed magnetizing reactive power passing only through the rotor.

### D. Electromagnetic Torque Characteristics

The electromagnetic power  $P_e$  passing through the rotor towards the stator, across the air gap, is equal to the power provided by the stator to the grid increased by the joules losses in the  $R_s$  resistance. With the adopted conventions, it is written:

$$P_e = -(P_s - R_s I_s^2) = R_s I_s^2 - P_s \quad (50)$$

$$= R_s \left( \frac{sV_s X'_\sigma + sV_s X_s - V'_{rd} X_s}{sR_s X'_\sigma + sR_s X_s + R_r X_s} \right)^2 - V_s \frac{sV_s X'_\sigma + sV_s X_s - V'_{rd} X_s}{sR_s X'_\sigma + sR_s X_s + R_r X_s}$$

The electromagnetic torque is consequently given by:

$$\Gamma_e = \frac{P_e}{\Omega_s} = \frac{R_s I_s^2 - P_s}{\Omega_s} \quad (51)$$

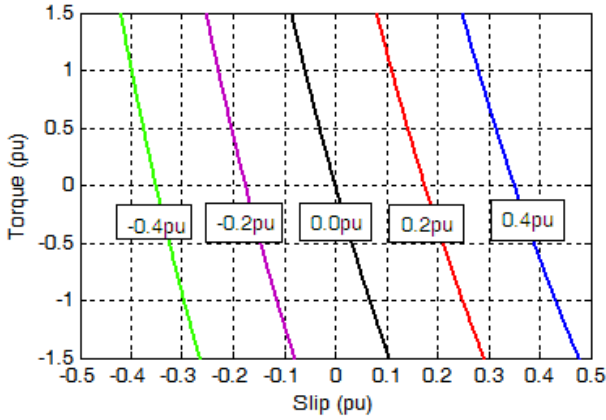

Fig. 10  $\Gamma_e$  versus slip for different value of  $V'_{rd}$

One can observe, in Fig.10, the electromagnetic torque characteristics versus the slip as variation in  $V'_{rd}$ . It is noted that the electromagnetic torque has a line equation if the torque not exceed the rated value. It is easy to give an explanation if  $R_s$  is made equal to zero in (50):

$$\Gamma_e = -\frac{V_s^2 (X'_\sigma + X_s)}{R'_r X_s \Omega_s} s + \frac{V_s}{R'_r \Omega_s} V'_{rd} \quad (52)$$

From (52), note that electromagnetic torque vary with a negative and constant slope:  $-V_s^2 (X'_\sigma + X_s) / R'_r X_s \Omega_s$ . This justifies the characteristics given on Fig. 10.

#### E. Reactive and Active Rotor Powers Characteristics

The reactive power  $Q_r$  provided by the rotor side inverter is used to magnetize the machine since the stator reactive power  $Q_s$  is imposed null. This last is given by:

$$\begin{aligned} Q_r &= \text{Im}(\bar{V}_r \bar{I}_r) = \text{Im}\left(V'_{rd} + jV'_{rq}\right) \left(-I_s + j\frac{R'_s I_s - V_s}{X_s}\right)^* \\ &= V'_{rq} I_s + \frac{V'_{rd}}{X_s} (V_s - R'_s I_s) \end{aligned} \quad (53)$$

The rotor side inverter provides to the rotor an active power given by:

$$\begin{aligned} P_r &= \text{Re}(\bar{V}_r \bar{I}_r) = \text{Re}\left(V'_{rd} + jV'_{rq}\right) \left(-I_s + j\frac{R'_s I_s - V_s}{X_s}\right)^* \\ &= -V'_{rd} I_s + \frac{V'_{rq}}{X_s} (V_s - R'_s I_s) \end{aligned} \quad (54)$$

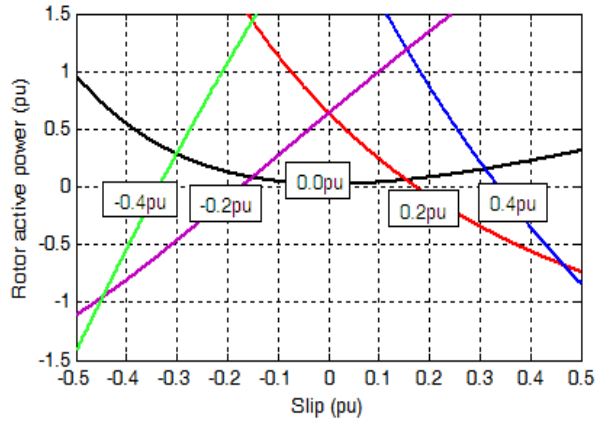

Fig. 11  $P_r$  versus slip for different value of  $V'_{rd}$

#### F. Global DFIM Active Power Characteristics

The active power of the generator  $P_{DFIM}$  was defined as being the sum of the power exchanged with the grid side stator and the inverter side rotor:

$$P_{DFIM} = P_s + P_r = (V_s - V'_{rd}) I_s + \frac{V'_{rq}}{X_s} (V_s - R'_s I_s) \quad (55)$$

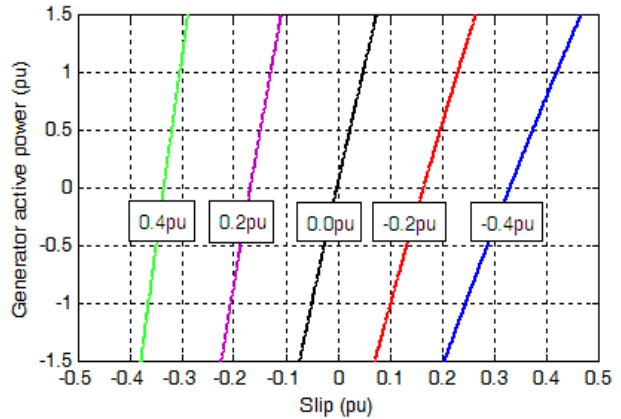

Fig. 12  $P_{DFIM}$  versus slip for different value of  $V'_{rd}$

#### IV. SAFETY OPERATING RANGES OF THE DFIM

To avoid the excessive heating of the machine's windings, it should be taken care that stator and rotor currents are below or equal to their rating values. Owing to the fact, the expression of the stator current is simpler; we give the limitation strategy by acting of the stator current.

##### A. Limitation by the Rotor Voltage

We suppose that the machine operates at a given slip, we thus calculate the voltage  $V'_{rd}$  to be applied to the rotor so that the machine stays within the acceptable limits of operation.

To answer the put question, it should be solved the following inequality:

$$\left( \frac{sV_s X'_\sigma + sV_s X_s - V'_{rd} X_s}{sR_s X'_\sigma + sR_s X_s + R_r X_s} \right)^2 \leq I_{s \max}^2 \quad (56)$$

The Resolution of this inequality enables to find the range of  $V'_{rd}$  to apply to the rotor to avoid overloading the machine. It is found that:

$$V'_{rd \min} \leq V'_{rd} \leq V'_{rd \max} \quad (57)$$

With:

$$V'_{rd \min} = \frac{1}{X_s} (s(V_s + R_s I_{s \max})(X_s + X'_\sigma) + R_r I_{s \max}) \quad (58)$$

$$V'_{rd \max} = \frac{1}{X_s} (s(V_s - R_s I_{s \max})(X_s + X'_\sigma) - R_r I_{s \max}) \quad (59)$$

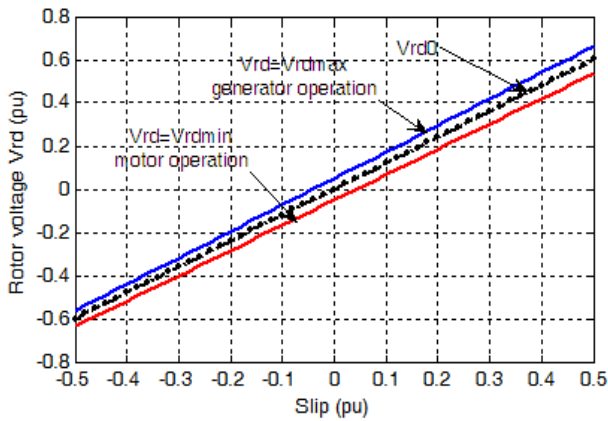

Fig. 13 Rotor voltage limits with regard to the slip

Fig.13 shows the acceptable operating range of the DFIM according to voltage  $V'_{rd}$  and the slip  $s$ . This range area is delimited by two lines: one corresponds to the maximum voltage  $V'_{rd \max}$  not to exceed and which coincides with generator operation. The other line delimits the minimal voltage  $V'_{rd \min}$  from which one should not go down and corresponds to motor operation.

The safety operating range is subdivided into two parts by a line corresponding to a null value of the stator current which admits as equation:

$$V'_{rd0} = \frac{V_s (X_s + X'_\sigma)}{X_s} s \quad (60)$$

#### B. Limitation by the Slip

The safety operating area of the DFIM can also be defined by acting on the slip  $s$  instead of the voltage  $V'_{rd}$ . By solving the inequality given by (60) it is found:

$$s_{\min} \leq s \leq s_{\max} \quad (61)$$

With:

$$s_{\min} = \frac{X_s (V'_{rd} - R_r I_{s \max})}{(X_s + X'_\sigma)(V_s + R_s I_{s \max})} \quad (62)$$

$$s_{\max} = \frac{X_s (V'_{rd} + R_r I_{s \max})}{(X_s + X'_\sigma)(V_s - R_s I_{s \max})} \quad (63)$$

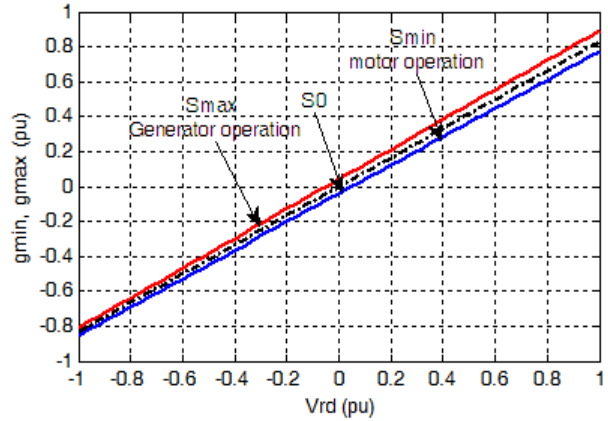

Fig. 14 Slip limits with regard to the rotor voltage

Fig. 14 shows that the acceptable operating area is delimited by two lines: one corresponding to the maximum slips  $s_{\max}$  not to exceed for a given voltage  $V'_{rd \min}$ . And the other line corresponds to the points of minimal slips  $s_{\min}$  of which one should not go down.

## V. OPEN LOOP CONTROL OF THE DFIM

In this section we propose an open loop control of the DFIM. The control has as a main aim to answer the following question: which is the value of the voltage to be applied to the rotor if we want to operate under a known applied torque and a desired mechanical speed? Moreover, the additional constraint to operate under a null reactive power must be verified. This open loop control doesn't require any sensor as in the case of other known controls.

To check the validity of the proposed control, numerical simulation results are given where the control is applied to the dynamic  $dq$  model of the DFIM. Constraints such as the current limitation and mechanical frictions will be taken into account to supplement this study.

#### A. Control Voltage Computation

Desired operating points can be imposed to the machine according to the rotor applied voltage. While placing in the case of the wind power system, to have an MPTT operation, the desired speed of the DFIM can be given by the measured wind speed. The applied torque can be known from the mechanical power available on the turbine shaft.

To find the voltage to be applied to the rotor, we proceed in two steps: to calculate initially the stator current  $I_s$  according to the applied torque then we calculate the voltage according to the slip and  $I_s$ .



The electromagnetic torque equation is first written as:

$$\Gamma_{em} = \frac{P_{airg}}{\Omega_s} = -\frac{P_s - R_s I_s^2}{\Omega_s} = -\frac{V_s I_s - R_s I_s^2}{\Omega_s} \quad (64)$$

To find the value of  $I_s$  corresponding to each value of  $\Gamma_{em}$ , we solve the second order equation (64) and we lead to the following results:

$$I_{s1} = \frac{1}{2R_s} (V_s - \sqrt{V_s^2 + 4\Gamma_e \Omega_s R_s}) \quad (65)$$

$$I_{s2} = -\frac{1}{2R_s} (V_s + \sqrt{V_s^2 + 4\Gamma_e \Omega_s R_s}) \quad (66)$$

The second solution,  $I_{s2}$  given by (66) is to be rejected since it gives only negative values.

Knowing the value of the  $I_s$  current, given by the equation (65), it is possible to deduce from (44) the voltage to be applied to the rotor according the desired mechanical speed:

$$V'_{rd} = -\frac{X_s + X'_\sigma}{X_s} (R_s I_s - V_s) s - R_r I_s \quad (67)$$

By introducing the mechanical speed  $\Omega$  :

$$V'_{rd} = -\frac{X_s + X'_\sigma}{\Omega_s X_s} (R_s I_s - V_s) (\Omega_s - \Omega) - R_r I_s \quad (68)$$

Obtaining the supply rotor voltage and the steady state control can be summarized by the following diagram:

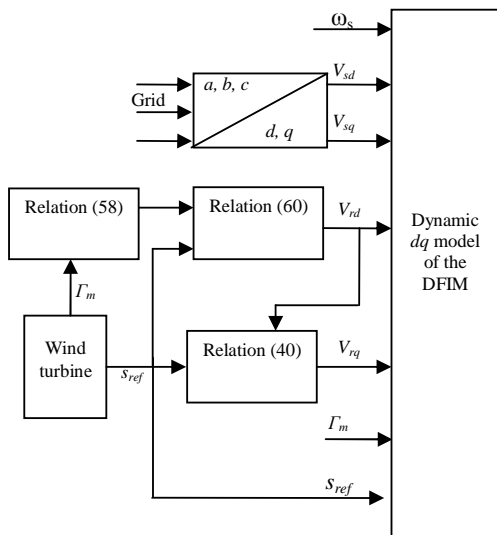

Fig. 15 Steady state control of the DFIM assuring a null reactive power and without any sensors

### B. Simulation and Results

A numeric simulation was carried out using MATLAB-Simulink software under the following conditions: the machine being at a standstill ( $s=1$ ), then we want that the DFIM start up and operates as generator and in sub-synchronous range. The applied torque is of 15 N-m and the desired slip is 0.3. The machine is connected to the grid; it is supplied with 220/380V balanced three-phase system and 50Hz of frequency. To avoid overflow of the currents, at the time of starting up, the reference slip is applied gradually using a weak negative slope. Remembered the proposed control ensures a null stator reactive power.

The simulation results shown at the Fig. 16 to 18 demonstrate that the desired operating point is well obtained and the reactive power is equal to zero. The proposed control is then validated.

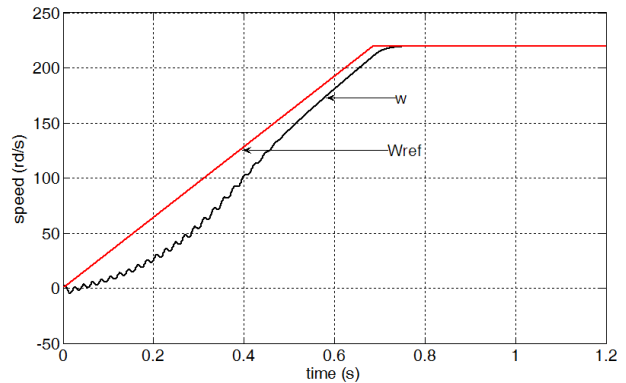

Fig. 16 Simulated reference speed and DFIM speed

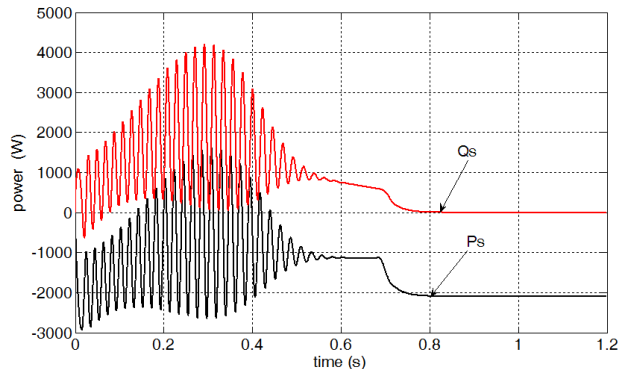

Fig. 17 Simulated stator active and reactive power

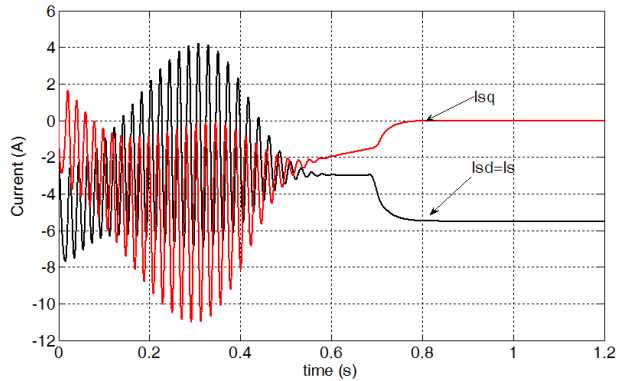

Fig. 18 Simulated stator current



## VI. CONCLUSION

In this work, it has been established the steady state characteristics of a DFIM under unity power factor operation. Driven from the forth synchronized model, it is given the relation between the rotor voltage components ensuring a zero reactive power at the stator. This assumption leads to very interesting analytical expression of the electromagnetic torque, the speed and the other sizes, permitting to understand the DFIM behaviors and to define the safety operating area. Moreover, the analytical expressions lead to a very interesting and easy open loop control of the DFIM without any sensors. The simplicity holds promise of greater reliability.

TABLE I  
STUDIED DFIM CHARACTERISTICS

Nominal power $P_n$	3Kw
Nominal supply voltage $\Delta/Y$	220V/380V
Stator rated current $\Delta/Y$	11A/6.3A
Nominal speed	1415 rpm
Stator resistance $R_s$	1.5 $\Omega$
Stator cyclic inductance $L_s$	260mH
Leakage coefficient $\sigma$	0.0872
Rotor constant $T_r$	0.099
Rotor resistance $R_r$	0.7 $\Omega$
Transformation ratio $a=L_s/L_m$	2.02

## REFERENCES

- [1] F. Poitiers, T. Bouaouiche, M. Machmoum. "Advanced control of a doubly-fed induction generator for wind energy conversion" *Electric Power Systems Research* 79, pp 1085–1096, 2009
- [2] Balduino Cezar Rabelo, Wilfried Hofmann, João Lucas da Silva, Rodrigo Gaiba de Oliveira and Selênio Rocha Silva: "Reactive Power Control Design in Doubly Fed Induction Generators for Wind Turbines" *IEEE Trans. Ind. Electron.*, Vol. 56, No. 10, pp 4154- 4162, Oct 2009.
- [3] José Fernando Medina Padrón and Andrés Elías Feijóo Lorenzo: "Calculating Steady-State Operating Conditions for Doubly-Fed Induction Generator Wind Turbines" *IEEE Trans. Power Syst.*, Vol. 25, No. 2, pp 922-928. May 2010.
- [4] A.E. Feioo, J. Cidras: "Modelling of wind farms in the load flow analysis" *IEEE Trans. On Power Syst.*, Vol. 15, No. 1, pp 110-115. February 2000.
- [5] D. Aguglia1, P. Viarouge, R. Wamkeue, J. Cros: "Analytical determination of steady state converter control laws for wind turbines equipped with doubly fed induction generators" *IET Renew. Power Gener.*, 2008, Vol. 2, No. 1, pp. 16–25.
- [6] Z.Wang, Y. Sun, G. Li, B.T. Ooi: "Magnitude and frequency control of grid connected doubly fed induction generator based on synchronised model for wind power generation," *IET Renew. Power Gener.*, Vol. 4, PP. 232-241, Iss. 3, Jan. 2010.
- [7] Chien-Hung Liu and Yuan-Yih Hsu: "Effect of Rotor Excitation Voltage on Steady-State Stability and Maximum Output Power of a Doubly Fed Induction Generator" *IEEE Trans. Ind. Electron.*, Vol. 58, No. 4, pp 1096- 1109, Apr 2011.

**Hamid Sediki** was born in Tizi-Ouzou, Algeria, on March 21, 1966. He obtained the Engineer, the Magister, and the Ph.D. degrees in Electrical Engineering from the University 2000, and 2010, respectively. He joined the University of Tizi-Ouzou in 1993, where he is currently working as Associate Professor. His main interests are power electronics and electrical drives.

**Djaffar Ould Abdeslam** was born in Tizi-Ouzou, Algeria, on April 20, 1976. In 2002, he received the M.Sc. degree in Electrical Engineering from the University of Franche-Comté, Besançon, France. In 2005, he obtained the Ph.D. degree from the University of Haute-Alsace, Mulhouse, France, where he is currently working as Associate Professor. His work concerns artificial neural networks applied to power active filters and power electronics.

**Tahar Otmane-cherif** was born in Tizi-Ouzou, Algeria; on February, 20, 1958. He received the Magister and the PHD degrees in Electrical Engineering from the University of Tizi-Ouzou, Algeria in 1994, and 2008, respectively. Currently, he is Associate Professor with the Department of Electrical Engineering, at the same university. His research interests include electrical machines and wind energy conversion systems.

**Ali Bechouche** was born in Tizi-Ouzou, Algeria, on December 09, 1982. He received the Engineer and the Magister degrees in Electrical Engineering from the University of Tizi-Ouzou, Algeria in 2007, and 2009, respectively. Currently, he is a Lecturer and a Researcher with the Department of Electrical Engineering, at the same university. His research interests include electrical drives and advanced techniques applied to wind energy conversion systems.

**K. Mesbah**, was born in Tizi-Ouzou, Algeria, on January 13, 1986. In 2011, he received the M.Sc. degree in Electrical Engineering from the University Of Tizi-Ouzou, Algeria in 2011. Currently he is a PHD student at the same university. His areas of interest are electric machines wind power generation.