

Stability Enhancement of a Large-Scale Power System Using Power System Stabilizer Based on Adaptive Neuro Fuzzy Inference System

Agung Budi Muljono, I Made Ginarsa, I Made Ari Nrartha

Abstract—A large-scale power system (LSPS) consists of two or more sub-systems connected by inter-connecting transmission. Loading pattern on an LSPS always changes from time to time and varies depend on consumer need. The serious instability problem is appeared in an LSPS due to load fluctuation in all of the bus. Adaptive neuro-fuzzy inference system (ANFIS)-based power system stabilizer (PSS) is presented to cover the stability problem and to enhance the stability of an LSPS. The ANFIS control is presented because the ANFIS control is more effective than Mamdani fuzzy control in the computation aspect. Simulation results show that the presented PSS is able to maintain the stability by decreasing peak overshoot to the value of -2.56×10^{-5} pu for rotor speed deviation $\Delta\omega_{2-3}$. The presented PSS also makes the settling time to achieve at 3.78 s on local mode oscillation. Furthermore, the presented PSS is able to improve the peak overshoot and settling time of $\Delta\omega_{3-9}$ to the value of -0.868×10^{-5} pu and at the time of 3.50 s for inter-area oscillation.

Keywords—ANFIS, large-scale, power system, PSS, stability enhancement.

I. INTRODUCTION

POWER system companies serve consumers to supply the power continuously on a wide-area operation with standard quality assurance. Some generation units, such as hydro, thermal, nuclear and gas power plants, are located out of city area. The power plants are connected to bulk power systems via interconnecting transmission line including high voltage direct current (HVDC) system. Meanwhile, almost all of power system consumers are located in city areas such as: trade/commercial and official complex areas, suburban area, industrial area and residential area. Analysis of an LSPS is usually very difficult and complicated. So, simplifying scheme should be done to resolve this difficulties problem. This LSPS is separated into some small part operation areas [1]. During operation time, the balancing of energy in respective synchronous machine makes the rotor machine to oscillate caused by load fluctuation at all load buses. To cover the rotor oscillation problem, PSS is presented at excitation system of synchronous machine to damp the rotor oscillation where, local mode stability of a pump storage power plant is significantly improved by using the PSS [2]. Furthermore, performance of a conventional PSS is maintained

by using additional or auxiliary loop [3]. Transient stability classification of an LSPS is done using support vector machine (SVM) model. The result of this research shows that the SVM model gives more accurate than multi-layer perceptron-neural network (MLP-NN) model. Also, by using the SVM model, the dimensionality of power system data can be reduced significantly than by using the MLP model [4].

Control schemes for electrical engineering field, such as neural network, fuzzy logic and neuro fuzzy controls, are grown up rapidly in recent years where, the conventional control function is complemented by the neural network, fuzzy or neuro fuzzy control function. Proportional integral and derivative-static var compensator based on recurrent neural network is used to suppress chaos and voltage collapse in a power system. This control scheme is able to control chaos and voltage collapse in a power system. This controller is able to maintain the load voltage at the setting value [5]. An ANFIS controller has been proposed and implemented to a multimachine power system. The result shows that the ANFIS controller can improve the dynamic stability of the multimachine power system [6], [7]. Adaptive critic design based (ADC) neuro-fuzzy controller is implemented to control the static compensator in an LSPS. Where the ADC neuro-fuzzy controller is more effective than PI controller in responding the small disturbing and short circuit fault [8]. The ANFIS-based composite controller-SVC and PID-loop are applied to control chaos and voltage collapse and to regulate the voltage at load bus with loading fluctuation [9], [10]. Also, the ANFIS controller is tried to maintain dynamic response of HVDC system [11] and to protect the HVDC devices from the short circuit [12]. Furthermore, ANFIS PSS has been applied to improve the stability of single machine based on feedback linearisation [13]. And, adaptive fuzzy rule-based PSS [14] and fuzzy logic PSS [15], [16] are also used to maintain dynamic stability of a power system. A Mamdani fuzzy control scheme is applied to hardware implementation to static compensator in an LSPS [17].

This paper presents an effective control strategy to enhance the stability of an LSPS using ANFIS PSS. The ANFIS method is used in this research; because the ANFIS is able to train from time-series data. Parameters of ANFIS controller are obtained by training processes in off-line mode. Furthermore, the parameters of ANFIS controller are adjusted automatically during the training processes using time-series data training. The data training is obtained by simulating the system equipped with conventional PSS and load capacity of

A. B. Muljono is with the Department of Electrical Engineering, University of Mataram. Jalan Majapahit No. 62, Mataram Indonesia 83125 (e-mail: agungbm@unram.ac.id).

I. M. Ginarsa and I. M. A. Nrartha are with the Department of Electrical Engineering, University of Mataram, Indonesia (e-mail: kadekgin@unram.ac.id, nrartha@te.ftunram.ac.id).

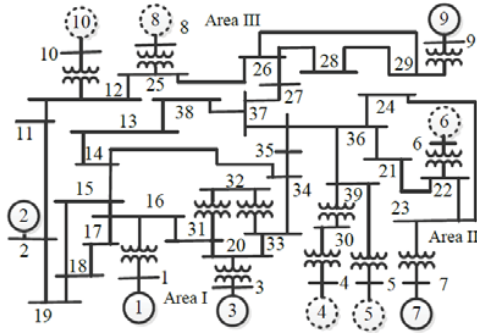

Fig. 1 Single-line diagram of a large-scale power system

the system is varied. So, this paper is organized as follows: Stability of a power system is described in Section II. Design of ANFIS PSS is detailed in Section III. Next, simulation result and analysis are presented in Section IV. And, the conclusion is provided in the last section.

II. STABILITY OF A POWER SYSTEM

A. Stability of a Single Machine

Stability is defined as the ability of power system to cover the disturbance at normal operation the effort to maintain the power system going to steady state after the disturbance disappeared. Dynamical behavior of a single machine connected to infinite bus is depended on interaction of turbine, generator, also the controller characteristic such as governor and excitation systems. Dynamical of a single machine formulas in linear model are as [18]:

$$\Delta \dot{\delta} = \omega_0 \Delta \omega \quad (1)$$

$$\Delta \dot{\omega} = \frac{1}{M} (\Delta T_m - \Delta T_e - D \Delta \omega) \quad (2)$$

B. LSPS

An LSPS consists of two or more local power system areas. Topology of existing LSPS usually follows the geographic surfaces. The local area is connected to the other by transmission line to form the LSPS. The LSPS in this research is taken from Padiyar [19]. This system consists of 39 buses and 10 machines, and it is shown in Fig. 1. For the simplification, the system was separated into three areas (Area I, Area II and Area III). The Area I was only covering the interaction of Machine-2 (M_2) and Machine-3 (M_3). Therefore, the Machine-1 (M_1) at Bus 1 was treated as a reference bus. Furthermore, the speed and angle rotor deviation were taken as zero values. So, the interaction of M_2 and M_3 is defined as local mode oscillation ($\Delta \omega_{2-3}$) and ($\Delta \delta_{2-3}$) in the Area I. The interaction of machines (M_2 and M_3) in the Area I to machines in other areas (M_7 and M_9) is defined as inter-area mode oscillation ($\Delta \omega_{2-7}$, $\Delta \omega_{2-9}$, $\Delta \omega_{3-7}$, $\Delta \omega_{3-9}$, $\Delta \delta_{2-7}$, $\Delta \delta_{2-9}$, $\Delta \delta_{3-7}$ and $\Delta \delta_{3-9}$).

PSS provides additional damping to rotor oscillation of machine by regulating its excitation system through an additional stabilizing signal. The PSS produces an electrical torque component in phase with the rotor speed deviation to provide the additional damping torque. The function of the PSS is very important to improve stability of overall power systems. Since the PSS is to introduce a damping torque component, a logical signal to use for regulating excitation system of machine is rotor speed deviation. And, output of the PSS is the additional voltage compensation that feeds to the excitation system. Conventional PSS consists of gain, washout and phase compensation blocks. The gain block determines the amount of damping introduced by the PSS. The signal washout block serves as a high frequency filter, with the time constant T_w . The phase compensation block provides appropriate phase lead characteristic to compensate the phase lag between exciter input and generator (air-gap) electrical torque [18].

An ANFIS is one part of artificial neural network method that combines the advantage of neural network and fuzzy logic properties. The ANFIS network is based on TakagiSugeno fuzzy inference system. The ANFIS works as a single framework model to represent the both neural network and fuzzy logic system. The ANFIS inference system uses a set of fuzzy IF-THEN rules to approximate nonlinear functions. The advantage of the ANFIS network is that it has learning ability to update the parameters automatically during training stage. The ANFIS consists of premise and consequence parameters. The ANFIS function is the same as the fuzzy rule based on Sugeno algorithm. Both of the parameters are obtained by off-line learning processes with least squares estimation (LSE) and back-propagation algorithms. At forward step, the parameters are identified by using LSE method. Meanwhile, at backward step, the parameters are updated and maintained by using gradient descent optimization. Suppose that the ANFIS network has 2 (two) inputs x, y and an output O , with 2 (two) rules based on first-order fuzzy model Sugeno [20]:

$$\begin{aligned} R^1 &: \text{If } x \text{ is } A_1 \text{ And } y \text{ is } B_1 \text{ Then } y_1 = p_1 x + q_1 y + r_1 \\ R^2 &: \text{If } x \text{ is } A_2 \text{ And } y \text{ is } B_2 \text{ Then } y_2 = p_2 x + q_2 y + r_2 \end{aligned} \quad (3)$$

output of the ANFIS-network is formulated as:

$$O_i = \frac{\sum_i \bar{w}_i f_i}{\sum_i \bar{w}_i} \quad (4)$$

Data training that is used for this learning process was obtained by simulating the conventional PSS. To obtain the data training, the LSPS is equipped by conventional PSS where the step function was used to implement the change of mechanical torque in the Machine-2 (M_2) due to load fluctuation. The ANFIS-based PSS block diagram is illustrated in Fig. 2. In this learning process, a 4000-data training set was used to design the ANFIS-based PSS. The inputs of ANFIS-based PSS were rotor speed deviation ($\Delta \omega_i$) and its derivative ($\Delta \dot{\omega}_i$). And, the output was an additional stabilizing signal (ΔV_{s_i}). Structure of the ANFIS PSS model was built by using 5 (five) Gaussian membership functions with the input and 25 (twenty-five) rules fuzzy Sugeno order 1 for the output,

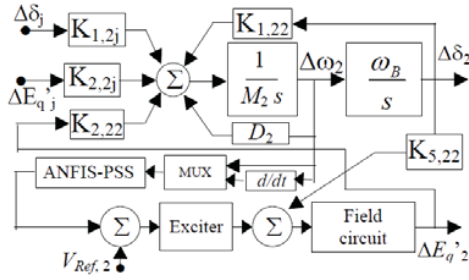

Fig. 2 ANFIS-based PSS in a large-scale power system

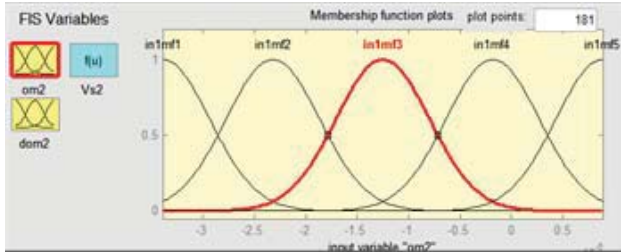
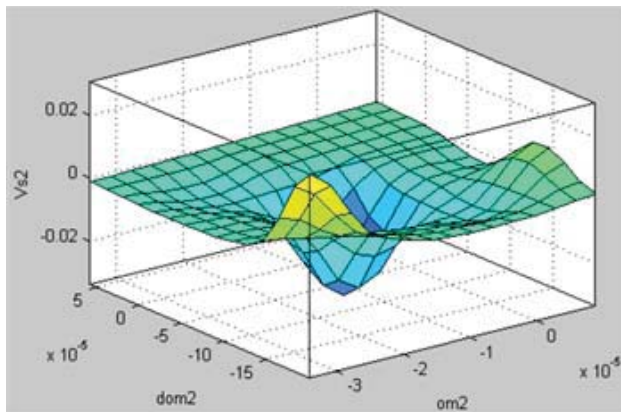

 Fig. 3 Input $\Delta\omega_2$ Gaussian membership function of ANFIS-based PSS

Fig. 4 Input-output control surface of ANFIS-based PSS

respectively. After some learning processes were conducted, the Sugeno fuzzy form of the PSS was built automatically. The membership function of input PSS ($\Delta\omega_2$) is illustrated in Fig. 3. Also, control surface of the respective input-output ANFIS-based PSS was generated automatically. A set of control surface was used to implement relationship between the input and output ANFIS-PSS as: $\Delta\omega_2 - \Delta\dot{\omega}_2 - \Delta V s_2$. This input-output control surface of the PSS is shown in Fig. 4. Finally, when the ANFIS-network was completely built, the ANFIS-based PSS in this scheme control was applied to replace the conventional PSS.

IV. RESULTS AND ANALYSIS

In this research, stability of an LSPS is enhanced by using ANFIS PSS at chosen machines. The effectiveness of the presented PSS is tested under disturbance represented by mechanical torque at 0.1 pu on Machine-2 (M_2). Simulation results were observed and assessed by monitoring the rotor speed and rotor angle deviation at local mode oscillation

($\Delta\omega_{2-3}$ and $\Delta\delta_{2-3}$). Also, the $\Delta\omega_{2-7}$, $\Delta\omega_{2-9}$, $\Delta\omega_{3-7}$, $\Delta\omega_{3-9}$, $\Delta\delta_{2-7}$, $\Delta\delta_{2-9}$, $\Delta\delta_{3-7}$ and $\Delta\delta_{3-9}$ were monitored and assessed as inter-area mode oscillations. And, The Matlab/Simulink Program [21] is used to simulate and validate the presented PSS on an Intel Core PC computer.

A. Stability Enhancement on Local Mode

An LSPS without equipped by any compensator is very vulnerable towards instability when it is disturbed/faulted during its operation time. On the other hand, the LSPS is able to maintain its stability significantly using the presented PSS. Fig. 5 (a) and Table I show that the ANFIS-based PSS (AP) was able to decrease the peak overshoot (P_o) of the rotor speed deviation ($\Delta\omega_{2-3}$) at the value of -2.56×10^{-5} pu. The settling time (S_t) of the ANFIS-based PSS response was also shortened to the time of 3.78 s. Meanwhile, the responses of conventional PSS (CP) and without any PSS (WP) are at the values of -2.82 and -3.55×10^{-5} pu, respectively. And, the S_t of the conventional and without PSS responses were the times of 4.63 and > 20 s, respectively. The CP and WP settling times are longer than the AP settling time.

Fig. 5 (b) and Table I illustrate that the peak overshoot (P_o) of the response of rotor angle deviation ($\Delta\delta_{2-3}$) decreases by the ANFIS-based PSS to the value of -0.331 deg. Also, the settling time of the ($\Delta\delta_{2-3}$) was achieved at the time of 4.01 s for the presented PSS (AP). On the other hand, when the system was equipped by the conventional PSS and without any PSS, the peak overshoot of the system was achieved at the values of -0.375 and -0.482 deg. And, the LSPS equipped by conventional PSS and without any PSS, the settling time was achieved at times of 5.39 and > 20 s, respectively.

Simulation results show the peak overshoot of the presented PSS is less than conventional PSS/without any PSS. The settling time of the presented PSS is shorter than other PSS. The presented PSS is able to give stability enhancement of the LSPS in local mode. Also, the presented PSS gives better performance to damp oscillation of the rotor between Machine-2 (M_2) and Machine-3 (M_3) in Area I.

B. Stability Enhancement on Inter-Area Mode

An LSPS always operates on balancing of mechanical-electrical input-output with synchronous consideration such as: Frequency/rotor speed, real-reactive power, voltage and phase among all the machines. Since the LSPS is operated without any compensation device or controller, it makes the system on very vulnerable to against disturbances such as: Change of loading, change of generation schedule, change of line/branch configuration and short circuit fault. Moreover, the LSPS can go under emergency state and serious instability problem. Furthermore, when the emergency operation is not handled accurately, the LSPS becomes into blackout mode. To cover this problem, the ANFIS PSS(s) are applied to the Machine-2, Machine-3, Machine-7 and Machine-9 simultaneously. The simulation results of the inter-area mode oscillation are as follows: Fig. 6 (a) and Table II show that the ANFIS-based PSS was able to enhance the peak overshoot of the $\Delta\omega_{2-7}$ response is at

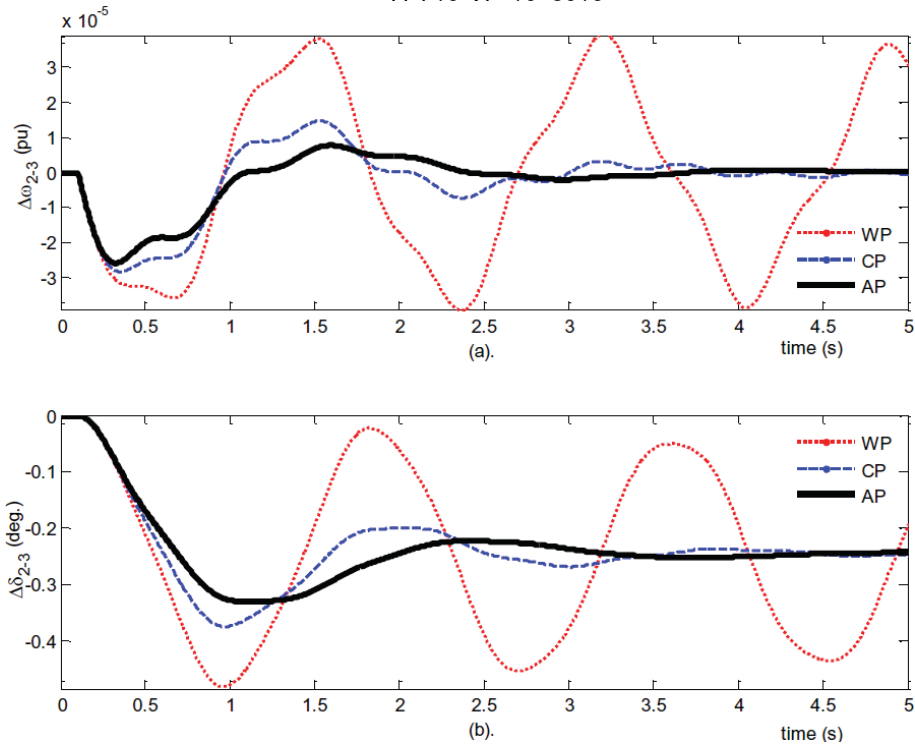

Fig. 5 Stability enhancement of (a) $\Delta\omega_{2-3}$ and (b) $\Delta\delta_{2-3}$ on local mode

TABLE I
RESPONSES OF ANFIS-PSS ON LOCAL MODE

P S S	$\Delta\omega_{2-3}$	Settling time	$\Delta\delta_{2-3}$	P_o	t_{st}	S_s
2-6	Peak overshoot	$[t_{st}](s)$	P_o	-(deg)	(s)	-(deg)
	$[P_o]-10^{-5}(pu)$					
W P	3.55	> 20.0	0.482	> 20.0		
1-5 C P	2.82	4.63	0.375	4.46	0.24	
1-5 A P	2.56	3.78	0.331	4.01		

the value of -3.09×10^{-5} pu. The settling time was also shortened to time of 3.74 s, while the peak overshoots of the conventional PSS and the system without any PSS responses are at the values of -3.81 and -5.06×10^{-5} pu, respectively. And, the settling time (S_t) of the conventional and without PSS were achieved at times of 4.51 and > 20 s, respectively.

Fig. 6 (b) and Table II illustrate the enhancement response of rotor angle deviation Machine-2 and Machine-7 ($\Delta\delta_{2-7}$) by the presented PSS at the value of -0.426 deg. The settling time of the ($\Delta\delta_{2-7}$) was achieved at the time of 4.22 s for the presented PSS (AP). On the other hand, when the system was equipped by the conventional PSS and without PSS, the system achieved the peak overshoot at the values of -0.474 and -0.609 deg. And, the conventional PSS and without PSS achieved the settling time at 4.45 and > 20 s, respectively. Furthermore, the steady state (S_s) of rotor angle deviation between M_2 - M_3 ($\Delta\delta_{2-7}$) was at -0.31 deg.

Fig. 7 (a) and Table II show that the AP was able to improve the peak overshoot of the rotor speed deviation ($\Delta\omega_{2-9}$) at the value of -3.07×10^{-5} pu. The settling time was also shortened to 3.02 s. Meanwhile, peak overshoot of CP and the WP responses were achieved at of -3.59 and -4.58×10^{-5} pu, respectively. And, the settling time of the CP and WP were

achieved at 4.56 and > 20 s, respectively.

Fig. 7 (b) and Table II illustrate the maintenance response of rotor angle deviation between Machine-2 and Machine-9 ($\Delta\delta_{2-9}$) by the presented PSS at the value of -0.402 deg. Also, the settling time of the $\Delta\delta_{2-9}$ was shortened to 4.02 s for the presented PSS. On the other hand, when the system was equipped by the CP and WP, the system achieved the peak overshoot at -0.449 and -0.577 deg. The settling times were at 4.49 and > 20 s for the CP and WP, respectively. Furthermore, the steady state (S_s) of rotor angle deviation ($\Delta\delta_{2-9}$) was achieved at -0.29 deg.

Fig. 8 (a) and Table II show that the AP was able to reduce the peak overshoot of the rotor speed deviation ($\Delta\omega_{3-7}$) at the value of -1.07×10^{-5} pu. The settling time was shortened to 3.6 s while, the peak overshoot of the CP and WP were achieved at -1.31 and -1.68×10^{-5} pu, respectively. And, the settling time (S_t) of the CP and WP were at 4.49 and > 20 s.

Fig. 8 (b) and Table II describe that the enhancement response of rotor angle deviation Machine-3 and Machine-7 ($\Delta\delta_{3-7}$) by the presented PSS at the value of -0.096 deg. Also, the settling time of the $\Delta\delta_{3-7}$ was shortened to 4.23 s. Meanwhile, when the system equipped CP and WP, the

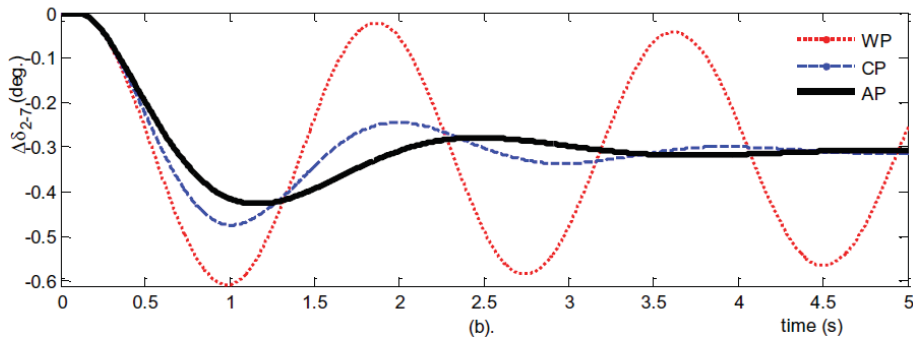
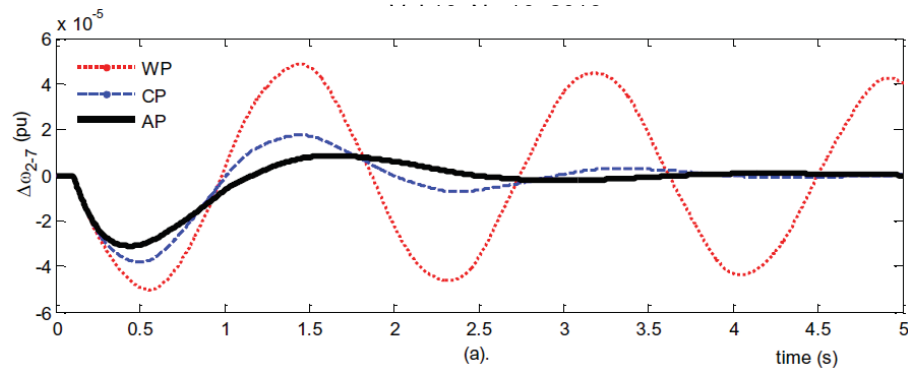

Fig. 6 Improvement of (a) $\Delta\omega_{2-7}$ and (b) $\Delta\delta_{2-7}$ on inter-area mode

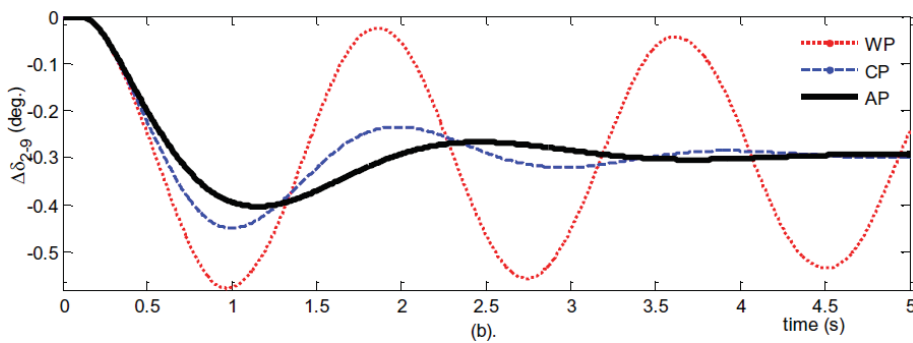
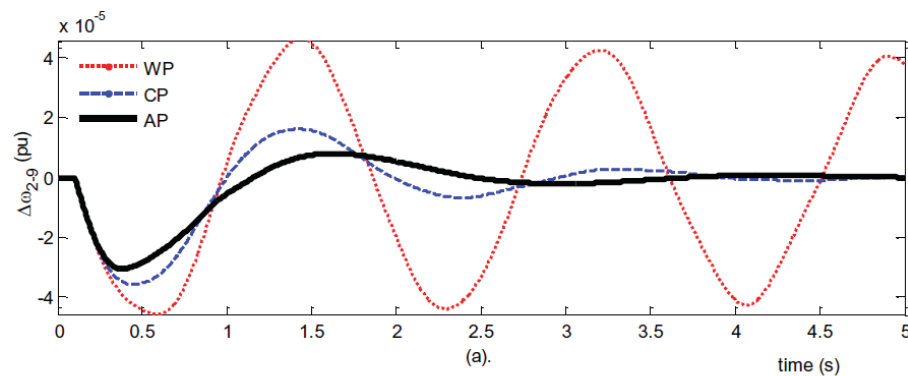

Fig. 7 The (a) $\Delta\omega_{2-9}$ and (b) $\Delta\delta_{2-9}$ responses on inter-area mode

system achieved the peak overshoot responses at -0.106 and -0.133 deg. And, when the system equipped by the CP and WP, the settling time were at 4.49 and > 20 s, respectively. Moreover, the steady state (S_s) of rotor angle

deviation ($\Delta\delta_{3-7}$) was achieved at -0.063 deg.

Fig. 9 (a) and Table II show that the AP was able to decrease the peak overshoot of the rotor speed deviation ($\Delta\omega_{3-9}$) to the value of -0.868×10^{-5} pu. The settling time was also

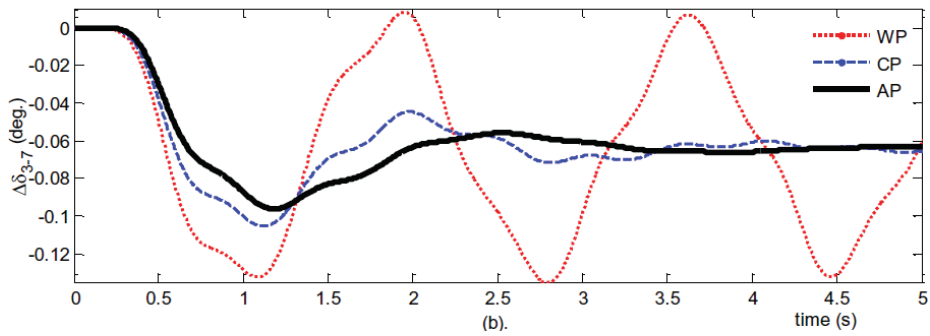
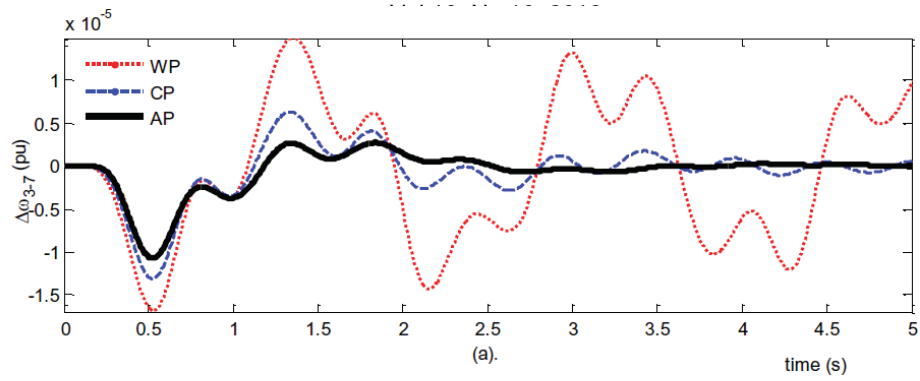

Fig. 8 Stability enhancement at (a) $\Delta\omega_{3-7}$ and (b) $\Delta\delta_{3-7}$ responses

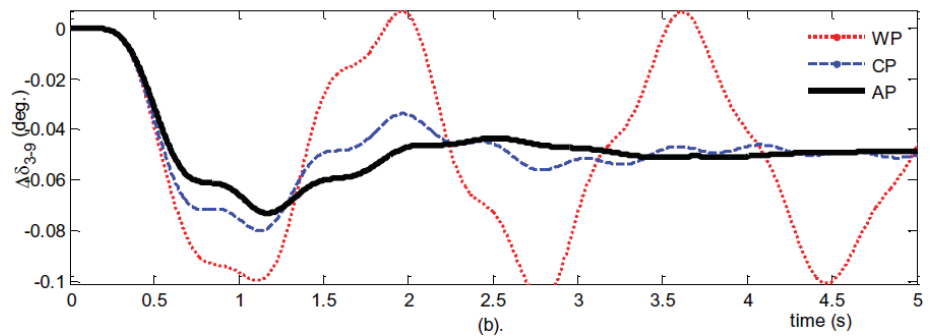
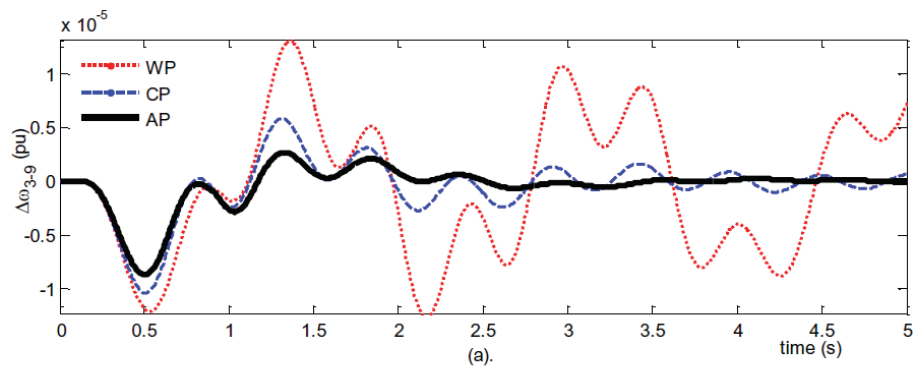

Fig. 9 Stability enhancement at (a) $\Delta\omega_{3-9}$ and (b) $\Delta\delta_{3-9}$ responses

reduced to 3.50 s. Meanwhile, peak overshoot of the CP and WP responses were achieved at -1.036 and -1.212×10^{-5} pu, respectively. And, the settling time of the CP and WP responses were at 4.58 and > 20 s.

Fig. 9 (b) and Table II illustrate the enhancement response of the rotor angle deviation Machine-2 and Machine-9 ($\Delta\delta_{3-9}$) by the presented PSS at -0.073 deg. Also, the settling time of the ($\Delta\delta_{3-9}$) was reduced to 3.51 s for the presented PSS.

P S S	$\Delta\omega_{2-7}$	Settling time	$\Delta\delta_{2-7}$	t_{st}	Ss
2-6	Peak overshoot [Po]- 10^{-5} (pu)	[t_{st}](s)	Po -(deg)	(s)	-(deg)
W P	5.06	> 20.0	0.609	> 20.0	
1-5 C P	3.81	4.51	0.474	4.45	0.31
1-5 A P	3.09	3.74	0.426	4.22	
	$\Delta\omega_{2-9}$		$\Delta\delta_{2-9}$		
2-6 W P	4.58	> 20.0	0.577	> 20.0	
2-5 C P	3.59	4.56	0.449	4.49	0.29
2-5 A P	3.07	4.45	0.402	4.01	
	$\Delta\omega_{3-7}$		$\Delta\delta_{3-7}$		
W P	1.68	> 20.0	0.133	> 20.0	
2-5 C P	1.31	4.49	0.106	4.49	0.063
2-5 A P	1.07	3.60	0.096	4.23	
	$\Delta\omega_{3-9}$		$\Delta\delta_{3-9}$		
W P	1.212	> 20.0	0.099	> 20.0	
2-5 C P	1.036	4.58	0.080	4.47	0.049
2-5 A P	0.868	3.50	0.073	3.51	

On the other hand, when the system was equipped by the CP and WP, the system achieved the peak overshoot at -0.08 and -0.099 deg. So, the CP and WP achieved the settling time at 4.47 and > 20 s, respectively. Furthermore, the steady state (S_s) of rotor angle deviation ($\Delta\delta_{3-9}$) was achieved at -0.049 deg.

The simulation results show that the effectiveness of the presented PSS to enhance dynamic stability of the LSPS. The presented PSS is able to reduce the peak overshoot of the rotor speed and angle deviation. Also, the settling time of the rotor speed and angle deviation that equipped by the presented PSS is shorter than the settling time of the other PSS. The presented PSS is able to maintain the LSPS on local and inter-area mode oscillations.

V. CONCLUSION

The growth of load demand is very rapid with complex loading type on a modern power system in recent years. The load demand always changes to follow the consumer behavior and activity in all time. Inline to this situation, a power system company should be able to keep all of machine on power plant still operated in synchronous frequency. Some efforts should be conducted to keep the mechanical-electrical energy balanced of internal machine from perspective power system engineer point of view. Since an LSPS is forced by a disturbance, the rotor speed and angle deviations are fluctuated in temporary time. This condition is called a rotor swing that correspond to real power balanced on respective machine. In this research, ANFIS PSS is proposed to cover this problem. Also, using the presented PSS, the enhancement of the rotor speed and angle stability are achieved by reducing of peak overshoot of rotor speed ($\Delta\omega_{2-3}$) and angle ($\Delta\delta_{2-3}$) to the values of -2.56×10^{-5} pu and -0.331 deg, respectively. Shortening of rotor speed and angle deviation settling time to times of 3.78 and 4.01 s in local mode oscillation. Moreover, decreasing of the peak overshoot of rotor speed ($\Delta\omega_{3-9}$) and angle deviation ($\Delta\delta_{3-9}$) to the values of -0.868×10^{-5} pu and -0.073 deg. Shortening of rotor speed and angle deviation settling time to times of 3.50 and 3.51 s in inter-area mode oscillation. The presented PSS is able to enhance the local

and inter-area mode oscillations of the LSPS dynamic stability significantly.

Future work: Dynamic stability enhancement in all machines by using ANFIS-based PSS or other controller scheme is the next research program. Also, optimization method should be considered to adjust the PSS parameter in order to accelerate the settling time and to reduce the peak overshoot of the respective responses.

ACKNOWLEDGMENT

The authors would like to thank to the Direktorat General of Higher Education (DGHE) the Research, Technology and Higher Education Ministry, Republic of Indonesia to financial support through Hibah Penelitian Fundamental 2015-2016. Also, the authors thank to the colleagues and students at Power System Laboratory Mataram University for well cooperation during this research was done.

REFERENCES

- [1] K. F. Zhang, X. Z. Dai, *Structural analysis of large-scale power systems*, Mathematica Problem in Eng., Hindawi Pub, 2012.
- [2] Y. Y. Hsu, C. C. Su, *Application of power system stabilizer on a system with pumped storage plant*, IEEE Trans. on Power Syst., Vol. 3, No. 1, 1988.
- [3] M. Saidy, F. M. Hughes, *Performance Improvement of a conventional power system stabilizer*, Elect. Power and Energy Syst., Vol. 17 No. 5, 1995.
- [4] L. S. Moulin, A. P. A. da Silva, M. A. El-Sharkawi, R.J. Marks II, *Support vector machines for transient stability analysis of large-scale power systems*, IEEE Trans. on Power Syst., Vol. 19, No. 2, 2004.
- [5] I. M. Ginarsa, A. B. Muljono, I. M. A. Nrartha, *Controlling chaos and voltage collapse using layered recurrent network-based PID-SVC in power systems*, Telkomnika, Vol. 11, No. 3, 2013.
- [6] A. B. Muljono, I. M. Ginarsa, I. M. A. Nrartha, *Dynamic stability improvement using ANFIS-based power system stabilizer in a multimachine power system* (In Bahasa Indonesia), Proc. of SENTIA, Polinema Malang, Vol. 7, pp. B16-B21, 2015.
- [7] A. B. Muljono, I. M. Ginarsa, I. M. A. Nrartha, *Dynamic stability improvement of multimachine power system using ANFIS-based power system stabilizer*, Telkomnika, Vol. 7, pp. B16-B21, 2015.
- [8] S. Mohagheghi, G. K. Venayagamoorthy, R.G. Harley, *Adaptive critic design based neuro-fuzzy controller for a static compensator in a multimachine power system*, IEEE Trans. on Power Syst., Vol. 21, No. 4, 2006.
- [9] I. M. Ginarsa, A. Soeprijanto, M. H. Purnomo, *Controlling chaos and voltage collapse using an ANFIS-based composite controller-static var compensator in power systems*, IJEPES, Vol. 46, pp. 79-88, 2013.

- [10] I. M. Ginarsa, A. Soeprijanto, M. H. Purnomo, Syafaruddin, T. Hiyama, *Improvement of transient voltage responses using an additional PID-loop on an ANFIS-based composite controller-SVC (CC-SVC) to control chaos and voltage collapse in power systems*, IEEJ Trans. on Power and Energy (Section B), Vol. 131, No. 10, pp. 836-848, 2011.
- [11] I. M. Ginarsa, A. B. Muljono, I. M. A. Nrartha, O. Zebua, *Regulation of 12-pulse rectifier converter using ANFIS-based controller in a HVDC transmission system*, in Integrated Sci-Tech: The Interdisciplinary Research Approach, Vol. 1, Chapt. 6, UPT Perpustakaan UNILA Lampung, pp. 44-53, 2015.
- [12] N. Bawane, A. G. Kothari, D. P. Kothari, *ANFIS based control and fault detection of HVDC converter*, HAIT Journal of Science and Engineering B, Vol. 2, No. 5-6, pp. 673-689, 2011.
- [13] I. M. Ginarsa, O. Zebua, *Stability improvement of single machine using ANFIS-PSS based on feedback-linearization*, Telkomnika, Vol. 12, No. 2, 2014.
- [14] T. Hussein, A. Shamekh, *Adaptive rule-base fuzzy power system stabilizer for a multi-machine system*, Proc. of the MED Conf., pp.1415-1419, 2013.
- [15] M. Kushwaha, R. Khare, *Dynamic stability enhancement of power system using fuzzy Logic based power system stabilizer*, Proc. of Int. Conf. on ICPEC, pp. 213-219, 2013.
- [16] B. Shah, *Comparative study of conventional and fuzzy based power system stabilizer*, Proc. of Int. Conf. on CSNT, IEEE, pp. 547-551, 2013.
- [17] S. Mohagheghi, G. K. Venayagamoorthy, R. G. Harley, *Adaptive critic design based neuro-fuzzy controller for a static compensator in a multimachine power system*, IEEE Trans. on Power Syst., Vol. 21, No. 4, 2006.
- [18] P. Kundur, *Power system stability and control*, EPRI. McGraw-Hill. New York, 1994.
- [19] K. R. Padiyar, *Power system dynamic stability and control*, John Wiley and Sons (Asia) Pte Ltd, Singapura, 1994.
- [20] J.-S. R. Jang, C. T. Sun and E. Mizutani, *Neuro-fuzzy and soft computing: A computational approach to learning and machine intelligence*, Prentice-Hall International, Inc., USA, 1997.
- [21] Matlab, *MATLAB Version 7.9.0.529 (2009b)*, The Mathworks Inc, 2009.



I Made Ari Nrartha was born in Denpasar, Bali Indonesia, on April 1973. He received in B.Eng and M.Eng in electrical eng. from Sepuluh Nopember Institute of Tech. (1997) and Gadjah Mada Univ. (2001). Since 1999 he was a lecturer at Electrical engineering, Mataram University. His research interests are power system dynamic and stability, transmission and distribution, optimization, power quality and artificial intelligent application in power systems. He was an active author and co-author research papers in national and international journal.



Agung Budi Muljono was born in Purwodadi, Grobogan, Central Java Indonesia, on February 1971. He received in B.Eng. and M.Eng in electrical engineering from Malang Institute of Technology (1996) and Gadjah Mada University (2000) Indonesia, respectively. Since 1998 he was a lecturer at electrical engineering, Mataram University. His research interests are power system transmission and distribution, power system dynamic and stability, energy planning and distributed generation (DG) in power systems. He was an active

author and co-author research papers in national and international journal.



I Made Ginarsa was born in Darmasaba, Badung Regency, Bali Indonesia, on March 1970. He received in B.Eng, M.Eng and Ph.D in electrical eng. from Udayana Univ. (1997), Gadjah Mada Univ. (2001) and Sepuluh Nopember Institute of Tech. (2012), Indonesia. Since 1999 he was a lecturer at Electrical engineering, Mataram University. In 2010 he was a member of Electric Power System Laboratory, Kumamoto Univ. Japan as a research student. His research interests are power system dynamic and stability, nonlinear dynamic in power

system, voltage stability and control, artificial intelligent application in power systems. His works have been presented in international seminars. Also, he was an active author and co-author in this field that his research papers have been published in national and international journal.