

Sprayer Boom Active Suspension Using Intelligent Active Force Control

M. Tahmasebi, R.A. Rahman, M. Mailah, M. Gohari

Abstract—The control of sprayer boom undesired vibrations pose a great challenge to investigators due to various disturbances and conditions. Sprayer boom movements lead to reduce of spread efficiency and crop yield. This paper describes the design of a novel control method for an active suspension system applying proportional-integral-derivative (PID) controller with an active force control (AFC) scheme integration of an iterative learning algorithm employed to a sprayer boom. The iterative learning as an intelligent method is principally used as a method to calculate the best value of the estimated inertia of the sprayer boom needed for the AFC loop. Results show that the proposed AFC-based scheme performs much better than the standard PID control technique. Also, this shows that the system is more robust and accurate.

Keywords—Active force control, sprayer boom, active suspension, iterative learning.

I. INTRODUCTION

AGRICULTURE productions are counted on the main source of nutrition, and one of the serious problems is crop protection. Chemical method is applied by farmers widely on conventional agriculture operations because this method needs less labour, and distribution is easy.

Sprayers distribute chemicals dissolved in water on crops uniformly via nozzles located on sprayer boom. During this treatment, using chemicals has negative effects on crop yield and environment named under-dose and over-dose, respectively. One of the crucial reasons for under-doses and over-doses in field is vertical and horizontal vibrations when the spray boom is moved on the roughness fields [1]. The more effective vibrations on the spray distribution pattern are jolting and yawing in the horizontal plane, and rolling in the vertical plane [2]. One of the earliest studies about effects of tractor rolling on spray boom distribution pattern was done by Mahalinga Iyer and Wills [3]. Moreover, other simulating models described differences in spray deposit distribution between 20% and 600% for the horizontal vibration and between 0% and 1000% for the vertical vibration [4]. Therefore, sprayers have been implemented by passive and active suspensions to attenuate the unwanted vibrations although most of used suspensions were made commercially.

M. Tahmasebi is with Department of System Dynamics and Control; Faculty of Mechanical Engineering, University Technology Malaysia, Johor, 81310, Malaysia (phone: 607-553-4611; fax: 607-553-4611; e-mail: tahmasebi.mona@gmail.com).

R. A. Rahman, is with Department of System Dynamics and Control; Faculty of Mechanical Engineering, University Technology Malaysia, Johor, Malaysia (e-mail: roslan@fkm.utm.my).

M. Mailah, is with Department of System Dynamics and Control; Faculty of Mechanical Engineering, University Technology Malaysia, Johor, Malaysia (e-mail: musa@fkm.utm.my).

M. Gohari is with the Department of System Dynamics and Control; Faculty of Mechanical Engineering, University Technology Malaysia, Johor, Malaysia (e-mail: moh.gohari@gmail.com).

M. Tahmasebi would like to express my gratitude to Universiti Teknologi Malaysia for supporting the research through the Research University Grant (GUP Tier 1 grant No. QJ130000/7124.00H66).

Generally, changing mechanical characteristics of passive suspensions is not simple for new condition whereas active suspensions have adaptation potential to change suspension constants in real time effectively. Several researchers have studied numerous active spray boom suspension strategies both theoretically and experimentally [2], [5]-[9]. Previously, conventional controllers such as proportional (P) and proportional-integral (PI) controllers were employed to control the vibration of sprayers.

Recently, active suspension systems of vehicles have been implemented by the new method named active force control (AFC) [10] – [12] whereas this idea was firstly introduced by Hewit and Burdess [13]. The original theory of AFC involves direct measurement and estimation of a number of known parameters to forecast its compensation action that is the actuated torque, angular acceleration and estimated mass inertia of the spray boom in this research. As the estimated mass inertia of spray boom multiplies to angular velocity of spray boom, the main computational part in AFC is estimation mass inertia. Firstly, usage of artificial intelligent (AI) techniques to estimate the inertia of the system had been introduced by Mailah [14]. The major advantages of AFC approach are simplicity, robustness, and high accuracy compared with conventional methods in controlling dynamical systems. It means the active suspension with AFC system can overcome on disturbances better compared to conventional controllers. Tahmasebi et al. have firstly employed AFC method to control the undesired vibration of sprayer boom directly via crude approximation [15]. Besides, using intelligent methods for predicting mass inertia can increase the efficiency of this type of controllers. One of the AI methods which is used successfully to calculate the estimated mass inertia is iterative learning (IL) technique [14].

The objective of this research is an AFC method known as a feedback control is employed to control a sprayer boom system successfully and robustly in presence of disturbances. The most important parameters in this scheme are the assumption of estimated mass in AFC loop and tuning of proportional-integral-derivative (PID) parameters in PID controller. IL scheme is added into the control scheme to compute the estimated inertia of a sprayer boom intelligently.

II. RESEARCH METHODOLOGY

A. Dynamic Model of Active Suspension

A schematic view of sprayer boom suspension on uneven soil is shown in Fig. 1. In this study, it is assumed that spray boom is pivoted to the sprayer chassis as a pendulum. Bumpiness in the field causes to produce roll motions in tractor chassis, and thus rolling of sprayer boom. An actuator should be considered to control roll movement of sprayer by using control system.

The general dynamic equation of motion is used to calculate required torque is given by [16]:

$$\tau = H(\theta) \ddot{\theta} + h(\theta, \dot{\theta}) + G(\theta) + \tau_e \quad (1)$$

Where

τ : Actuated torque vector

H : $N \times N$ inertia matrix of actuator and manipulator

h : Centripetal and coriolis torque vector

G : Gravitational torque vector

τ_e : External disturbance torque vector

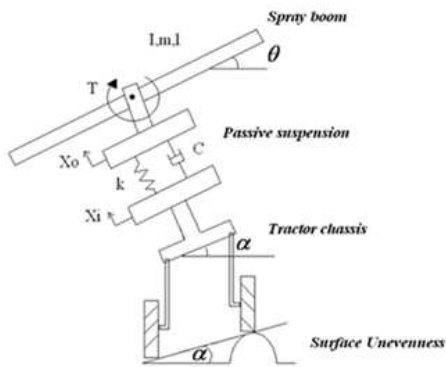

Fig. 1 A schematic diagram of sprayer boom on uneven soil α = Tilt angle of chassis, θ = spray boom tilt angle, l = length of boom, m = mass of sprayer, I = mass inertia of boom, T = torque of actuator, C = damper coefficient and k = spring constant

In this research, gravitational torque is neglected because the sprayer boom is pivoted to the frame, and the pendulum has two sides. Additionally, there is no coriolis torque as the boom is considered rigid body. In other words, the inertia torque, rotational friction at the joint and electrical armature, shock absorber, and external disturbances including brake force of electrical motor, external mass like as bird is considered, and the equation is follows:

$$\tau = I \ddot{\theta} + c \dot{\theta} + K\theta + \tau_e \quad (2)$$

B. Controller Design

The design of the control system includes three steps; first of all, the designs of PID controller; then, the incorporation of AFC into the PID control system and finally, the addition of an iterative learning (IL) algorithm into the AFC loop to estimate the spray boom inertia.

1) PID Control

The PID controller is a generic control loop feedback mechanism is widely exploited in industrial control systems. The PID control design is first stage to implementation of AFC, and it is shown by the outermost loop of the proposed scheme. The transfer function of a PID is given by:

$$G_c(s) = K_p + \frac{K_i}{s} + K_d s \quad (3)$$

Where K_p , K_i , K_d are the proportional, integral and derivative gains, respectively. By tuning the three parameters in the PID controller algorithm, the controller can provide control action designed for specific process requirements. The gains were obtained heuristically in this study.

2) Active Force Control

In the next stage, the AFC scheme is incorporated with the PID control loop by adding the AFC loop as depicted. As mentioned before, Hewitt and Burdett used the AFC method to a robotic arm, and the results showed that by using AFC the system remain stable and robust in presence of internal and external disturbances [13]. The performance of the system improves significantly by using this 2-DOF controller. The AFC part provides the extra robustness characteristic through its disturbance rejection capability [17].

The main AFC algorithm can be formulated as:

$$\tau^* = \tau - I^* \ddot{\theta} \quad (4)$$

Where I^* is estimated inertia, τ is actuated torque, $\ddot{\theta}$ is actual acceleration and T^* is estimated disturbances torque. Since the estimated inertia multiplies to acceleration, one of the key points in AFC feed forward loop is how to obtain the appropriate estimated inertia matrix so that the compensation of the disturbances can be successfully carried out. In this research, the estimated inertia is achieved through a iterative learning method.

3) Iterative Learning

The concept of IL method was firstly carried out by Katkovnik and Pervozvanski (1973) for the discrete-time systems [18] while Arimoto *et al.* suggested this algorithm for the continuous-time systems who proposed a new control concept called betterment process [19].

In this study, a PD type IL algorithm derived from Arimoto's study is used which is mathematically expressed as follows:

$$IN_{k+1} = IN_k + (\Phi + \Gamma d/dt) e_k \quad (5)$$

Where IN_{k+1} is the next step value of estimated inertia matrix, IN_k is the current estimated inertia matrix, e_k is the current track error and Φ , Γ are suitable positive learning parameters. Fig. 2 shows the scheme of AFC with a PD type IL algorithm. The dashed box depicted in the figure indicates the AFC with IL loop.

The main idea in IL technique is to use the situation that the system to be controlled will carry out the same operation several times. It will be possible to gradually improve the performance of the control system by using the results from previous repetitions.

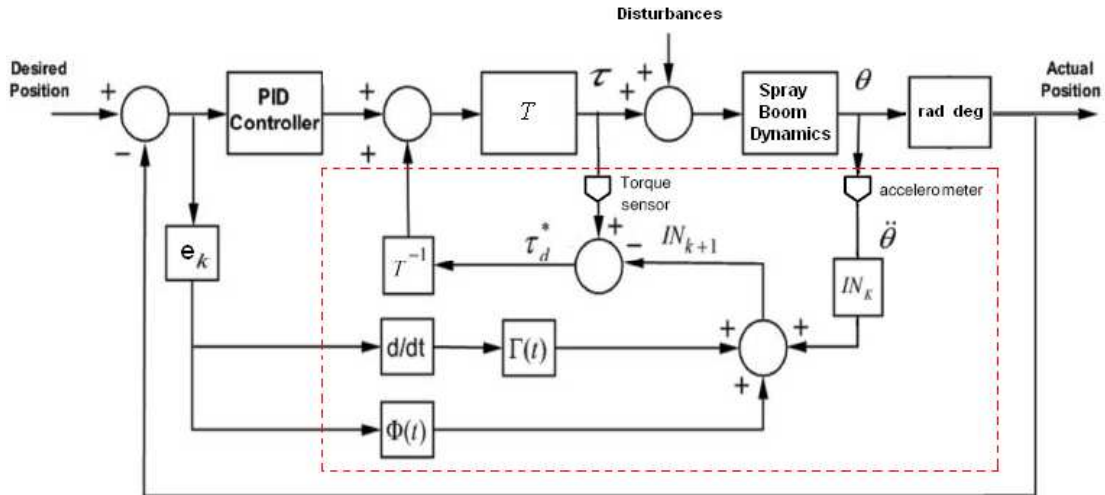

Fig. 2 The scheme of AFC with a PD type iterative learning algorithm

C. Simulation

The system dynamic model, PID controller, and AFC are modelled in the Simulink environment which is illustrated in Fig. 3. Initially, all the controller parameters (PID, AFC and IL) require to be archived to the implementation of the overall scheme.

The simulation parameters of PID and spray boom were employed in this study are shown in Table I to Table II, respectively.

The PD type IL learning parameters were set as follows:
 $\phi = 0.007$ $\Gamma = 0.0001$

TABLE I
OBTAINED PID PARAMETERS

PID parameters	Value
Proportional gain	300
Integral gain	140
Derivative gain	140

TABLE II
SPRAY BOOM PARAMETERS

Spray boom parameters	Value
Mass (kg)	0.6
Length (m)	2.4
Outer radius (m)	0.01
Inner radius (m)	0.008

Several trials were performed to find out the appropriate values for IL learning constants and the results proposed that the assumed values are acceptable. The sample time instant for the learning algorithms was set to 0.1s while the initial condition has been set as $I = 1.2 \text{ kgm}^2$. The motor constant was considered 0.3 Nm/A which was obtained from the actual data sheet for the heavy duty DC torque motor. The dynamic model of system was derived from Equation (2). Furthermore, the step and constant value were applied to the system to test the system response. The disturbance models were fed into loop that are:

Constant disturbance torque: 10 Nm

Sinusoidal wave: $Q = 25 \sin(10t) \text{ Nm}$

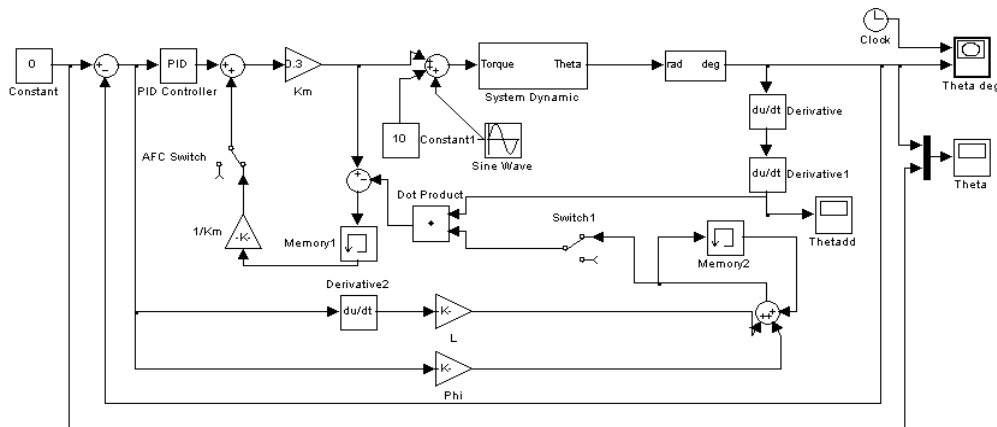

Fig. 3 The simulink model for AFC-IL scheme

III. RESULTS AND DISCUSSION

Fig. 4 through Fig. 6 shows the comparison between the simulation results with three various inputs that are step input, sinusoidal wave and constant value, respectively. The amplitude and frequency of sine wave were considered in order to 0.04 m [20] and 4.4 Hz [21]. In each case, the yellow line shows the response of the proposed control system although the pink line is for input signal. It is very obvious that the AFC method produces the best performance compared to PID control. This shows that the system is more robust and effective. Moreover, the comparison between using PID and AFC schemes shows overshoot and steady state error were decreased almost 50% and 96%, respectively. The results confirm the previous research result [15], but by using IL method the computational speed is higher than crude approximation method.

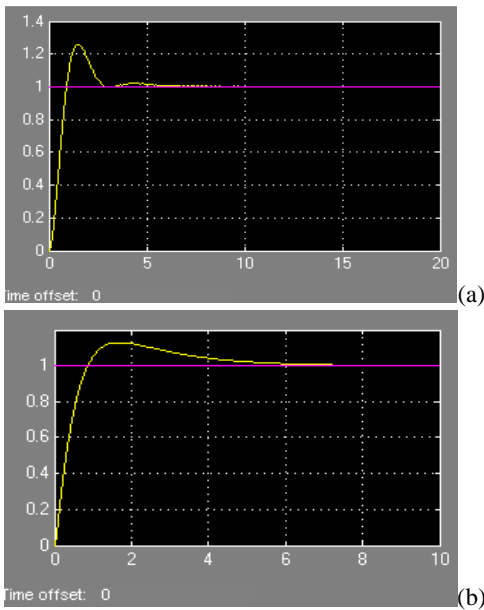

Fig. 4 The response of (a) PID control and (b) AFC scheme for step input

In Fig. 5 and Fig. 6, it is obvious that the performance of AFC is better than conventional controller alone in this case.

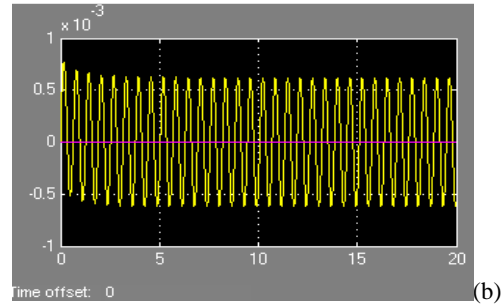
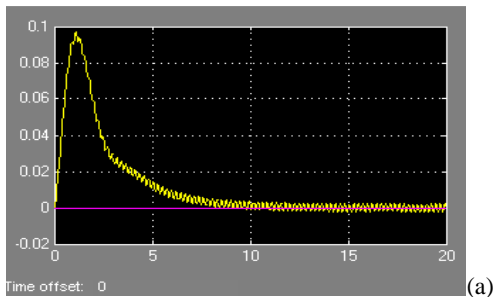

Fig. 5 The response of (a) PID control and (b) AFC method for zero degree

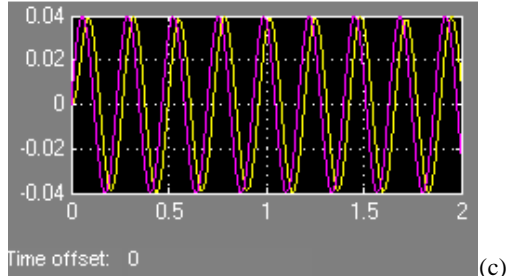
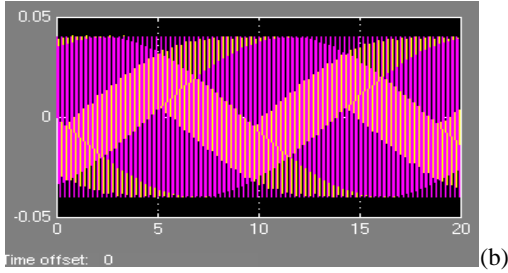
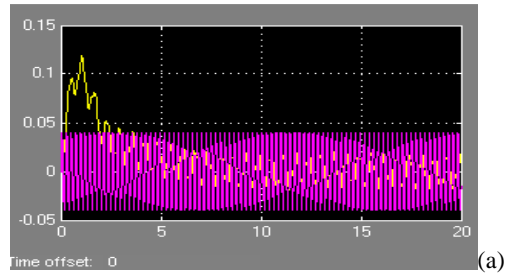

Fig. 6 The response of (a) PID control and (b) AFC method, c) AFC method after magnification for sinusoidal signal, respectively

IV. CONCLUSION

A new type of control method in the form of iterative learning active force control for an active suspension system of spray boom had been designed and simulated. Results illustrate that for given parameters and condition, the proposed system AFC-IL yields improve performance compared to the performance compared to the conventional control considered in the study. The AFC-based scheme can manage to suppress the disturbances effectively during the spraying operation. However, additional research should be performed to study the effects of other disturbances, different loading conditions, uncertainties and parametric changes.

REFERENCES

- [1] J. J. Langenakens, L. Clijman, H. Ramon, & J. De Baerdemaeker, "The Effects of Vertical Sprayer Boom Movements on the Uniformity of Spray Distribution," *J. agric. Engng Res.*, vol. 74, pp. 281-291, 1999.
- [2] J. Anthonis, J. Audenaert, & H. Ramon, "Design Optimisation for the Vertical Suspension of a Crop Sprayer Boom," *Biosystems Eng.*, vol. 90, no. 2, pp. 153-160, 2005.
- [3] B. Mahalinga Iyer, & B. M. J. Wills, "Factors determining the design of tractor-mounted sprayer booms-sprayer nozzle characteristics," *J. Agric. Engng. Res.* Vol. 23, pp. 37-43, 1978.
- [4] J.J. Langenakens, H. Ramon, & J. De Baerdemaeker, "A model for measuring the effect of tire pressure and driving speed on the horizontal sprayer boom movements and spray patterns," *Transactions of the ASAE*, vol. 38, no. 1, pp. 65-72, 1995.
- [5] A. R. Frost, "Simulation of an Active Spray boom Suspension," *J. agric. Engng Res.*, vol. 30, pp. 313-325, 1984.
- [6] A.R. Frost, & J. A. O'Sullivan, "Verification of a Mathematical Model for a Passive Spray Boom Suspension," *J. agric. Engng Res.*, vol. 34, pp. 245-255, 1986.
- [7] H. Ramon, D. Anthonis, D. Moshou, & J. De Baerdemaeker, "Evaluation of a Cascade Compensator for Horizontal Vibrations of a Flexible Spray Boom," *J. agric. Engng Res.*, vol. 71, pp. 81-92, 1998.
- [8] K. Deprez, J. Anthonis, & H. Ramon, "System for vertical boom corrections on hilly fields," *Journal of Sound and Vibration*, vol. 266, pp. 613-624, 2003.
- [9] J. Anthonis, & H. Ramon, "Design of an active suspension to suppress the horizontal vibrations of a spray boom," *Journal of Sound and Vibration*, vol. 266, pp. 573-583, 2003.
- [10] M. Mailah, & G. Priyandoko, "Simulation of a suspension system with adaptive fuzzy active force control," *Int. J. Simul. Model.*, vol. 6, pp. 25-36, 2007.
- [11] C. Alexandru, & P. Alexandru, "The Virtual Prototype of a Mechatronic Suspension System with Active Force Control," *Journal WSEAS Transaction on Systems*, vol. 9, no. 9, pp. 927-936, 2010.
- [12] K. Rajeswari, & P. Lakshmi, "Simulation of suspension system with intelligent active force control," In proceeding of International Conference on Advanced in Recent Technologies in Communication and Computing, 2010, pp. 271-27.
- [13] J. R. Hewit, & J. S. Burdess, "Fast Dynamic Decoupled Control for Robotics using Active Force Control," *Trans. Mechanism and Machine Theory*, vol. 16, no. 5, pp. 535-542, 1981.
- [14] M. Mailah, (1998). Intelligent Active Force Control of a Rigid Robot Arm Using Neural Network and Iterative Learning Algorithms. University of Dundee, UK: Ph.D Thesis.
- [15] M. Tahmasebi, R.A. Rahman, M. Mialah, & M. Gohari, "Active Force Control Applied to Spray Boom Structure," *Applied Mechanics and Materials Journal* (In press).
- [16] J. J. Craig, "Introduction to Robotics: Mechanics and Control," Pearson Prentice Hall, 2005.
- [17] G. Priyandoko, M. Mailah, & H. Jamaluddin, "Vehicle active suspension system using skyhood adaptive neuro active force control," In processing of Mechanical Systems and Signal, 2008.
- [18] V. Katkovnik, & A. Pervozvanski, "Extremum search methods and multivariable control systems," *Journal of Cybernetics*, vol. 3, no. 2, pp. 81-101, 1973.
- [19] S. Arimoto, S. Kawamura, & F. Miyazaki, "Bettering operation of robots by learning," *Journal of Robotic Systems*, vol. 1, pp. 123-140, 1984.
- [20] ISO 5008. (1979). ISO title: Agricultural wheeled tractors and field machinery - Measurement of whole-body vibration of the operator.
- [21] A.J. Bukta, K. Sakai, A. Sasao, & S. Shibusawa, "Free Play as a Source of Nonlinearity in Tractor-Implement Systems during Transport," *Transaction of ASAE*, vol. 45, no. 3, pp. 503-508, 2002.