

Space Vector Pulse Width Modulation Technique Based Design and Simulation of a Three-Phase Voltage Source Converter Systems

Farhan Beg

Abstract—A Space Vector based Pulse Width Modulation control technique for the three-phase PWM converter is proposed in this paper. The proposed control scheme is based on a synchronous reference frame model. High performance and efficiency is obtained with regards to the DC bus voltage and the power factor considerations of the PWM rectifier thus leading to low losses. MATLAB/SIMULINK are used as a platform for the simulations and a SIMULINK model is presented in the paper. The results show that the proposed model demonstrates better performance and properties compared to the traditional SPWM method and the method improves the dynamic performance of the closed loop drastically.

For the Space Vector based Pulse Width Modulation, Sine signal is the reference waveform and triangle waveform is the carrier waveform. When the value sine signal is large than triangle signal, the pulse will start produce to high. And then when the triangular signals higher than sine signal, the pulse will come to low. SPWM output will changed by changing the value of the modulation index and frequency used in this system to produce more pulse width. The more pulse width produced, the output voltage will have lower harmonics contents and the resolution increase.

Keywords—Power Factor, SVPWM, PWM rectifier, SPWM.

I. INTRODUCTION

POWER electronic equipment is advancing to new scales of performance like never before and is being widely touted as a solution for most of the power conversion and power quality issues. Even though on a wider scale power electronics has advanced but certain key issues remain unabated such as the low input power factor, harmonic distortion of ac line currents, and harmonic interference on the grid in case of a standard diode/thyristor based bridge rectifier. For DC loads or voltage source fed drives, the PWM rectifier/converter is a preferred choice for the production of a DC voltage. This may be attributed to the inherent capability of PWM based rectifier to regulate the power factor, and mitigate the line current harmonics as well as the bi-directional power flow capability [1], [2].

For improving the input power factor and shaping the input current into sinusoidal waveform many control strategies have been proposed. One of the simplest strategies is the Phase and Amplitude control (PAC) which provides a good switching pattern but a decrease in the closed loop stability is observed because of the DC offset on the input current of the rectifier

during the transient state. Advantages such as good accuracy, constant switching frequency, insensitivity to parameter variations and fast dynamic current response are observed in the current regulating fashion in the synchronous frame [3]. The direct current control scheme is widely adopted in the actual implementations. Even though many different PWM modulation schemes are presently being used, such as the delta modulation technique, the space vector technique and the sinusoidal PWM technique, but it has been theoretically proved that the Space vector PWM technique offers the best modulation properties. SVPWM provides a highly dynamic and robust way to suppress the input harmonics as well as for specific applications such as motor velocity control. Especially in low operating frequency, low harmonics can be obtained. One more benefit of using SVPWM technique consists of raising the fundamental component in the output voltage by about 15%. Development of digital signal processing has clearly provided a platform for the implementation of SVPWM. This paper proposes the modeling of a Three-Phase Space Vector Controlled Voltage source pulse PWM rectifier rated at 22kW. The simulations and results demonstrate the robust capability of the proposed scheme. The proposed algorithm avoids the superficial usage of the look-up tables of sine or arc-tangent that forms the basic mechanism for the design of the controller in a traditional framework. Duty cycles of space voltage vectors are directly calculated by tracking the voltage reference vector in each sector in the vector space.

II. SYSTEM DESCRIPTION AND MODELING

Fig. 1 shows the schematic of the three-phase voltage source converter based on IGBT's. In developing the mathematical model, it is assumed that the source voltage employed in a balanced three phase supply and a linear filter reactor is used. The IGBT's are also assumed to be lossless and ideal [4]. The various quantities in the mathematical model used are; u_a, u_b, u_c represent the per phase voltage of the three phase voltage source and i_a, i_b, i_c represent the phase current set. v_{dc} represents the DC o/p voltage and R_L, L signifies the Resistance and Inductance of the filter circuit. C is the smoothing capacitor and R_L is the DC side load. u_{ra}, u_{rb}, u_{rc} represent the input voltages of the rectifier circuit [5].

Farhan Beg is an Electrical Engineer from the National Institute of Technology Srinagar, India and is affiliated with the Global Energy Network Institute San Diego California USA (e-mail: f.beg1@yahoo.com).

$$\begin{aligned} L \frac{di_d}{dt} &= -R_1 i_d + \omega L i_q + u_d - u_{rd} \\ L \frac{di_q}{dt} &= -R_1 i_q + \omega L i_d + u_q - u_{rq} \\ C \frac{dV_{dc}}{dx} &= -V_{dc}/R_L + 3/2 (S_d i_d + S_q i_q) \end{aligned} \quad (1)$$

where, “w” is the angular frequency, u_d, u_q, i_d, i_q are the voltage and current in the synchronously rotating d-q frame respectively and S_d, S_q are the switch functions in the d-q frame.

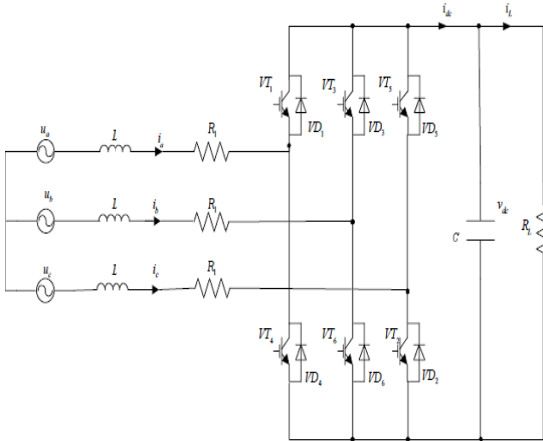

Fig. 1 Schematic of a three phase two level converter

Equation (1) clearly shows the dependence of both of the coupling voltages $\omega L i_q$ and $\omega L i_d$ and main voltages u_d, u_q on d-q current. Moreover, (1) can further be modified and regulated to ensure that the (2) is within limits.

$$\begin{aligned} u_{rd} &= -u'_{rd} + \omega L i_q + u'_{rd} \\ u_{rq} &= -u'_{rq} + \omega L i_d + u'_{rq} \end{aligned} \quad (2)$$

Equation (3) can be obtained by using the values of (2) in (1), i.e.,

$$\begin{cases} L \frac{di_d}{dt} = -i_d R_1 + u'_{rd} \\ L \frac{di_q}{dt} = -i_q R_1 + u'_{rq} \end{cases} \quad (3)$$

A cursory look of (2) and (3) suggests that u'_{rd} and u'_{rq} are decoupled and are only related with i_d, i_q respectively. Current and voltage regulation is implemented with simple PI regulators. Fig. 2 shows the implementation of a double closed loop control strategy which observes the current decoupling of the PWM converter.

Fig. 2 elucidates the decoupling process such that each of the PI regulated currents obtained are injected with the other axis current components.

However, when u_{rd} and u_{rq} are required, d-q to α - β transformation is used to realized the SVPWM which is used to regulate the DC bus voltage by tracing the current command accurately.

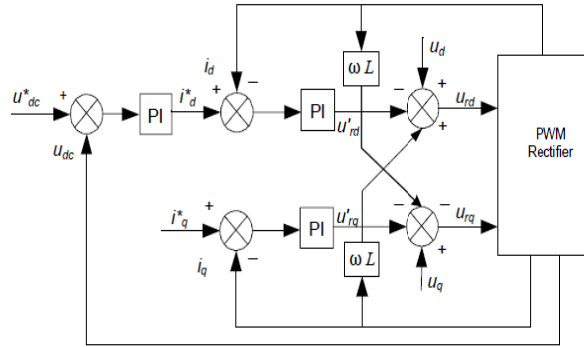

Fig. 2 Control block diagram of the dual closed loop controller of the PWM converter

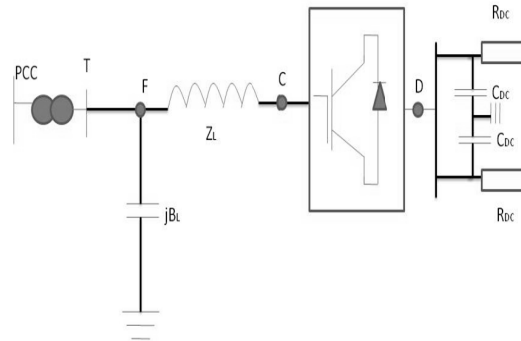

Fig. 3 Schematic of a two terminal VSC-HVDC

III. SYNTHESIZATION OF VOLTAGE VECTOR SPACE

The bridge rectifier leg voltages can assume 8 possible states depending on the switching state of the circuit in Fig. 1. The voltage states are represented as voltage vectors (V_0 to V_7) in the α - β coordinate system. The vectors are shown in Fig. 4. While as (V_1 and V_7) are two zero vectors, (V_1 to V_6) are six fixed non zero vectors, all of the same magnitude equal to the dc bus voltage V_{dc} . The three phase voltages can be represented as the voltage vector V_s . In order to synthesize the voltage vector V_s , many different methods of modulation exist depending on the combinations of the eight vectors used. The two phase modulation in which one switch is always kept ON or OFF in one working cycle can significantly lower the switching loss. Sampling of the desired reference vector is done in every sub-cycle T_s and is brought about by taking averaging the nearest three space vectors in the vector plane [6], [7]. In Fig. 4, the reference vector of magnitude V_s and phase theta θ in sector 1, is realized by using the active vector 1 the zero vector and the active vector 2. Durations of the three space vectors T_1, T_2, T_0 are calculated using the following formulas [8]:

$$\begin{aligned} T_1 &= \frac{T}{2V_{dc}} (3V_{sa} - \sqrt{3}v_{sb}) \\ T_2 &= \sqrt{3} \frac{T}{V_{dc}} V_{sb} \\ T_0 &= T_s - T_1 - T_2 \end{aligned} \quad (4)$$

For other sectors, the vector synthetic method is similar. For

universal variables X, Y, Z the expressions developed are shown as:

$$\begin{cases} X = \sqrt{3} \frac{T}{V_{dc}} V_{sB} \\ Y = \frac{\sqrt{3}}{2} \frac{T}{V_{dc}} V_{sB} + \frac{3}{2} \frac{T}{V_{dc}} V_{sA} \\ Z = \frac{\sqrt{3}}{2} \frac{T}{V_{dc}} V_{sB} - \frac{3}{2} \frac{T}{V_{dc}} V_{sA} \end{cases} \quad (5)$$

Phase voltages in abc coordinates can be obtained using the relationships (6);

$$\begin{cases} V_a = V_{sB} \\ V_b = -1/2 V_{sB} + \sqrt{3}/2 V_{sA} \\ V_c = -\frac{1}{2} V_{sB} - \sqrt{3}/2 V_{sA} \end{cases} \quad (6)$$

Using the properties of the 3-Phase Sine wave;

- If $V_a > 0$; $A=1$, else $A=0$
- If $V_b > 0$; $B=1$, else $B=0$
- If $V_c > 0$; $C=1$, else $C=0$

Sector number is consequently obtained using (7);

$$\text{Sector} = A + 2B + 4C \quad (7)$$

In order to optimize the number of device switches for a given PWM application period, only one switching is allowed per transition of the state. For this purpose, a peculiar arrangement of the three zero vectors is made as in Fig. 5.

IV. SIMULATION RESULTS AND ANALYSIS

MATLAB/ SIMULINK platform is used for the design and simulation of the proposed control strategy. System behavior is approximated as a discrete control system. The complete simulation model is shown in Fig. 6. The rectifier is shown in the top part of the Fig. 6. As already conected, the AC source used is a balanced three phase voltage source with a frequency of 50 Hz and a per phase voltage of 380 volts. The value of the line resistance is .1 ohms and the line inductance has a value of 3 mH. A value of 600 V is assumed for the DC voltage in the steady state. Switching frequency of 10 KHz is employed.

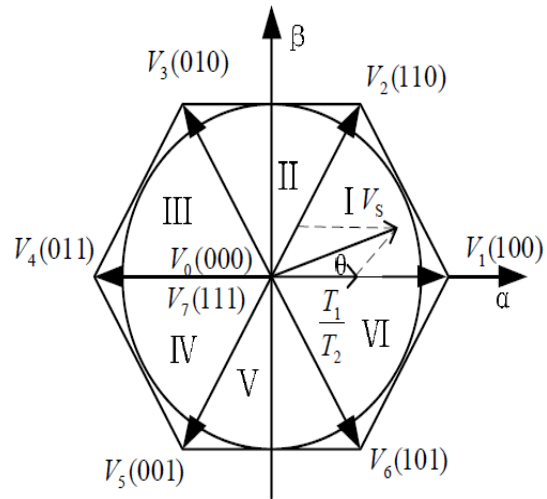

Fig. 4 PWM bridge rectifier voltages space vector representation

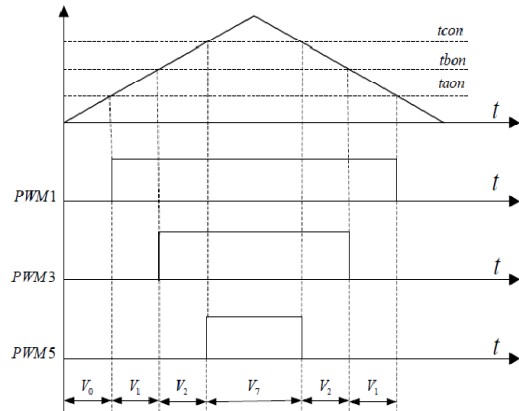

Fig. 5 Sector wise conventional and switching sequence

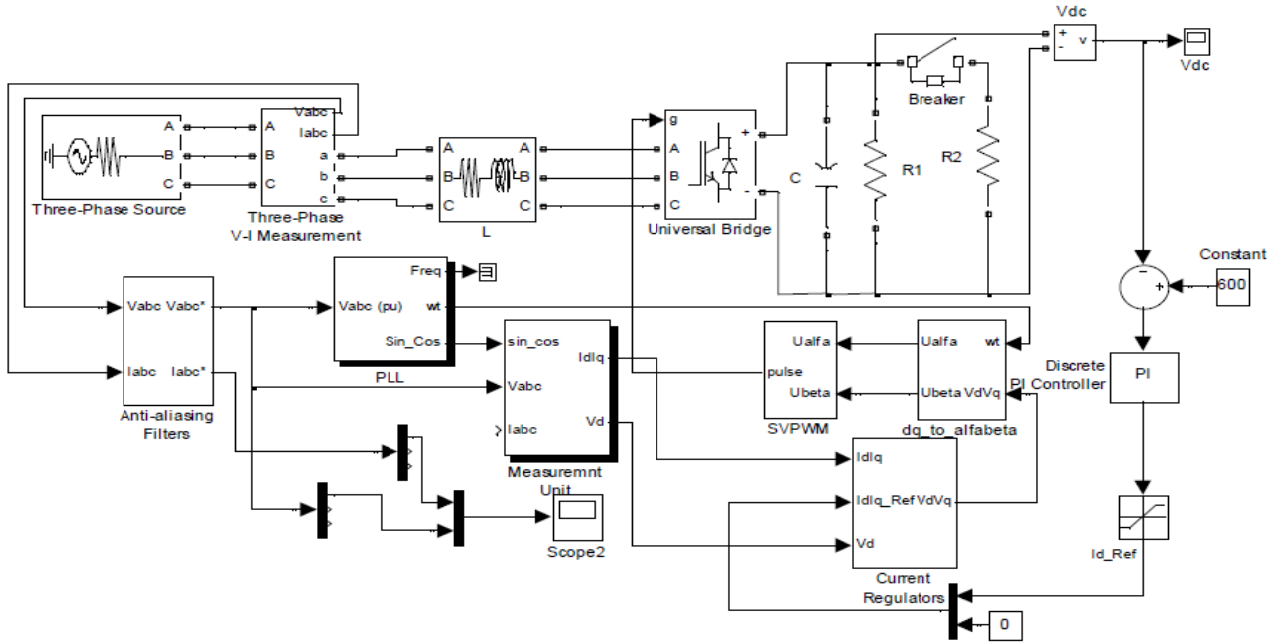

Fig. 6 System model of a three phase voltage source PWM rectifier system

Simulations were conducted to demonstrate the performance of the proposed control strategy. Figs. 7 and 8 consist of the simulation results. Fig. 7 shows the transient response of the output voltage while as Fig. 8 demonstrates the transient response of the input current. At the onset, the DC bus voltage rests at the diode rectification level with a load of $R_L=16\text{ohms}$. Control action applied thence, raises the output voltage to the desired DC value. Fig. 8 demonstrates the line side voltage and current and it be easily observed that the current of the sinusoidal wave has the same phase as the voltage.

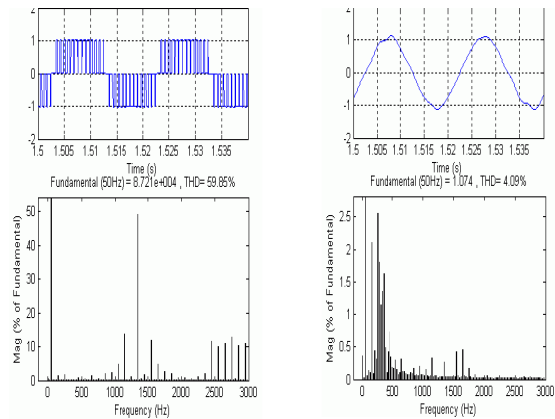

Fig. 8 Line current simulation result

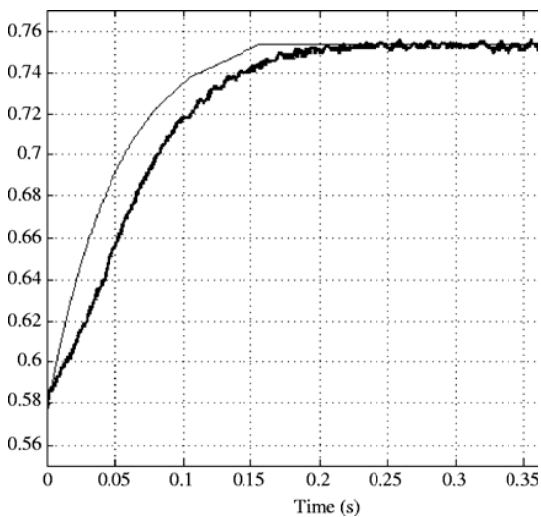

Fig. 7 DC link voltage dynamics simulation result

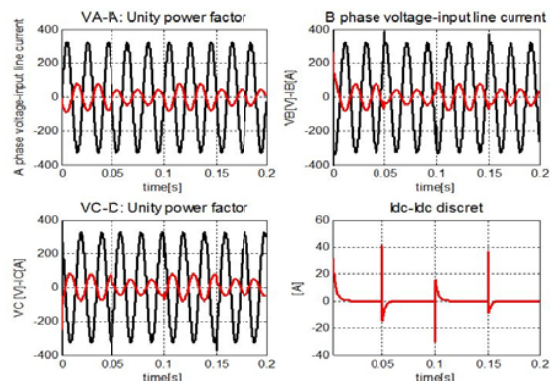

Fig. 9 Harmonic content and THD

V. CONCLUSION

In this paper, a simplistic model of the rectifier at unity power factor is introduced and the proposed control strategy leads to a significant improvement in the performance of the model. Conventional non-linear models can be modified to linear models using non linear input transformation technique.

The consequent design of the controller becomes straightforward. Independent design of the controller is made possible by the proposed technique. A design of the decoupled feed-forward controller for 3 phase voltage is proposed in this paper. Simulation results demonstrate the modifications in the performance in both DC as well as reactive power control. Minimum hardware is required for the design of the SVPWM controller and the IGBT switching losses are reduced.

REFERENCES

- [1] Alves, R. L., & Barbi, I. (2009). Analysis and implementation of a hybrid high-power-factor three-phase unidirectional rectifier. *Power Electronics, IEEE Transactions on*, 24(3), 632-640.
- [2] Ye, Y., M. Kazerani, and V. H. Quintana. "A novel modeling and control method for three-phase PWM converters." In *Power Electronics Specialists Conference, 2001. PESC. 2001 IEEE 32nd Annual*, vol. 1, pp. 102-107. IEEE, 2001.
- [3] Liao, Juinne-Ching, and Sheng-Nian Yeh. "A novel instantaneous power control strategy and analytic model for integrated rectifier/inverter systems." *Power Electronics, IEEE Transactions on* 15.6 (2000): 996-1006.
- [4] Zhou, Keliang, and Danwei Wang. "Relationship between space-vector modulation and three-phase carrier-based PWM: a comprehensive analysis [three-phase inverters]." *Industrial Electronics, IEEE Transactions on* 49.1 (2002): 186-196.
- [5] Celanovic, Nikola, and Dushan Boroyevich. "A fast space-vector modulation algorithm for multilevel three-phase converters." *Industry Applications, IEEE Transactions on* 37.2 (2001): 637-641.
- [6] Zhao, Yifan, and Thomas A. Lipo. "Space vector PWM control of dual three-phase induction machine using vector space decomposition." *Industry Applications, IEEE Transactions on* 31.5 (1995): 1100-1109.
- [7] Van Der Broeck, Heinz Willi, H-C. Skudelny, and Georg Viktor Stanke. "Analysis and realization of a pulsewidth modulator based on voltage space vectors." *Industry Applications, IEEE Transactions on* 24.1 (1988): 142-150.
- [8] Bowes, Sidney R., and Yen-Shin Lai. "The relationship between space-vector modulation and regular-sampled PWM." *Industrial Electronics, IEEE Transactions on* 44.5 (1997): 670-679.