

Simulation of Agri-Food Supply Chains

Sherine Beshara, Khaled S. El-Kilany, Noha M. Galal

Abstract—Supply chain management has become more challenging with the emerging trend of globalization and sustainability. Lately, research related to perishable products supply chains, in particular agricultural food products, has emerged. This is attributed to the additional complexity of managing this type of supply chains with the recently increased concern of public health, food quality, food safety, demand and price variability, and the limited lifetime of these products. Inventory management for agri-food supply chains is of vital importance due to the product perishability and customers' strive for quality. This paper concentrates on developing a simulation model of a real life case study of a two echelon production-distribution system for agri-food products. The objective is to improve a set of performance measures by developing a simulation model that helps in evaluating and analysing the performance of these supply chains. Simulation results showed that it can help in improving overall system performance.

Keywords—Agri-food supply chains, inventory model, modelling and Simulation, supply chain.

I. INTRODUCTION

ONE of the supply chains of perishable products is the Agri-food Supply Chain (ASC) which is the supply chain of agricultural products.

Perish-ability refers to physical deterioration of a product, which represent a huge challenge on the performance of supply chain. The difference between ASC and any other supply chain is the effect of factors like food quality, food safety, and weather related variability [1]. The ASC of fresh products, which are highly perishable, face problems of short product lifetime making it even more complex. The importance of ASC can be easily seen from the actual numbers of consumption of the agricultural products where 9% of the US gross domestic product (GDP) was from food and agricultural sector [2]. Globalization caused a change in customer's preference; they are now asking for higher product variety and better quality of fresh produce in supermarkets; this lead to the increase of export and import of these products around the world as they are produced in specific

Sherine Beshara, B. Sc., is a postgraduate student at the Department of Industrial and Management Engineering; College of Engineering and Technology; Arab Academy for Science, Technology, and Maritime Transport; AbuKir Campus, P.O. Box 1029, Alexandria, Egypt (phone: +203-561-0755; fax: +203-562-2915; e-mail: Sherineb@gmail.com).

Khaled S. El-Kilany, Ph. D., is an Associate Professor and Chairman; Department of Industrial and Management Engineering; College of Engineering and Technology; Arab Academy for Science, Technology, and Maritime Transport; AbuKir Campus, P.O. Box 1029, Alexandria, Egypt (e-mail: kkilany@aast.edu).

Noha M. Galal, Ph. D., is an Assistant Professor; Department of Industrial and Management Engineering; College of Engineering and Technology; Arab Academy for Science, Technology, and Maritime Transport; AbuKir Campus, P.O. Box 1029, Alexandria, Egypt (e-mail: noha.galal@staff.aast.edu).

geographical locations. In the US, winter produce is from Mexico and South America; in Europe, it is from Spain, Turkey, and North Africa. Supermarkets now realize that competitive advantage is gained by the quality of goods assortment which is the reason some customers prefer a supermarket over another [3].

A typical example is the recent increase in import in Europe of fruits from Egypt and Morocco; where, it is a big challenge to keep products fresh during transportation and prevent decay. Corporations have turned increasingly to global sources for their supplies leading to supply chains encompassing two or more countries.

This has encouraged developing countries to start focusing on export; where, some of these countries rely on agriculture as a constituent of their economic sector. It leads to a change in the competition now that domestic markets are competing internationally. All this growth is why it is necessary to apply supply chain management strategies to agri-food supply chains for effective planning and control over this long chain and to increase competitiveness in the global market.

This work focuses on the inventory replenishment model of an agri-food supply chain of highly perishable products. The objective is to improve a set of performance measures by developing a simulation model that helps in evaluating and analysing the performance of these supply chains.

The paper is organized as follows: Section 2 is concerned with literature review on the ASC to identify the existing gaps of literature; Section 3 presents the case study and data collection. In Section 4, the development of the model is discussed. Finally, Results of the simulation and highlight on areas of future research are discussed in Section 5.

II. LITERATURE REVIEW

A considerable amount of research has been concerned with agri-food supply chains (ASC). This brief review considers only journal papers published in the period of 2008 to 2011. The reviewed literature may be classified according to four aspects: the management and planning level considered, the supply chain driver addressed, performance measure used, and the analytical and solution techniques applied. Furthermore, research gaps in the field of ASC are identified.

A. Management and Planning Level

The Management and planning level addressed signifies the decision level of the supply chain. Three different levels are identified: The managerial or strategic level, the planning level, and the operational level.

The strategic level is concerned with setting long term basic strategies. The planning level is where short term policies that

manage the operations are set, and the operational level is responsible for implementing these policies.

Most of the reviewed papers has covered the planning level [4-11] followed by the strategic level [12-17]. The operational level is the least addressed in the reviewed papers and has been addressed as a complementary part of the planning level [5, 8, and 11].

B. Supply Chain Driver

Drivers of the supply chain are the key of evaluating the performance of the supply chain; they consist of logistical drivers (facility, inventory and transportation) and cross functional drivers (information, sourcing and pricing). Based on the conducted review, the most addressed driver is inventory, followed by information, then transportation and finally pricing. Where, none of the reviewed papers addressed the facility or sourcing.

C. Performance Measure

Performance measurement is very important in supply chain to help adequately assess the success or failure of the chain. The supply chain council [18] developed a classification based on: reliability measures, cost measures, responsiveness measure, and asset measurement.

The asset which is inventory is again the greatest one used, followed by responsiveness. The least used measures are cost followed by reliability.

Sustainability, i.e. the simultaneous consideration of economic, environmental, and social dimensions; has been added. Only few of the reviewed paper addressed sustainability. In this respect, emphasis was laid on environmental impact measuring mainly the waste of the product due to deterioration. Yet, social aspect has not been considered in the reviewed literature.

D. Analytical Tool and Solution Technique

The analytical tools used to measure or to calculate the performance indicator can fall in one of three groups: analytical, simulation, and others. Most of the reviewed papers used analytical approaches, followed by the use of simulation models. The solution technique refers to the way of solving the problem, in other words how to find the results needed. There are a number of techniques which may be categorized as follows: exact solution techniques, meta-heuristics, and simulation. The most commonly used technique is the exact solution method, followed by simulation, and meta-heuristic techniques.

E. Review Results

In conclusion, it can be clearly seen from the review that most of the attention given to the ASC is related to inventory or economic aspects. Although inventory is very important in the ASC due to the products' unique characteristics; there are other drivers in need for more research like transportation particularly due to globalization as stated before.

In addition to the above stated economic aspects, focus on environmental aspects should be increased. The waste of

product should be considered together with waste of energy during storage and transport in order to arrive at a trade-off between the economic and environmental dimensions.

From the reviewed literature the social dimension of the ASC was totally ignored. Hence, it is suggested to develop some performance measures for jointly considering the economic, environmental and social aspects to ensure sustainability.

Finally, product quality is a critical factor determining the success of the ASC. Hence, performance measure evaluating product qualities need to be developed. There is a need to close the gap between research and implementation and there should also be a trend in using mapping tools and solution techniques like simulation since it helps in studying real life situations.

III. CASE STUDY

In order to help closing the gap between the research and implementation of ASCs, a real life case study is selected for investigation. This work studies the inventory and replenishment policy of an ASC; the objective is to develop a simulation model that mimics the actual system and to evaluate its performance. The considered supply chain is a two echelon agri-food supply chain that stretches between two different countries; Egypt and Holland.

The supply chain is concerned with the production and distribution of perishable products; namely, fruits and vegetables. The supply chain network consists of two single-node echelons representing production and distribution. The production echelon is located in Egypt while the distribution echelon is in Holland. The current study investigates a single product which is oranges having a lifetime of 6 weeks. Data are collected from the last season consisting of 5 months. Structural, operational, and numerical data are presented in this section.

A. Structural Data

The product flow through the supply chain is described in this section to show the different parts of the supply chain under study. It starts at the farms (supplier) that send the fresh produce to the production facility, followed by distribution centre, retailers, and finally customers.

The production facility is a pack house that receives the oranges from suppliers, prepares the oranges, and packs it in special pallets containing 1.25 kg each. These are stored until the containers arrive to transport them to the port where they are shipped to the distributor in Holland. Owing to the perishable nature of the product the company tries to keep the inventory level as low as possible with products that are already packed on pallets.

The product is transported by ship in special containers called frigo containers preserving the product's temperature at a specified level.

The second echelon of the supply chain consists of the distribution facility which has a large warehouse to store the

products that arrive from the producer until they are sold to the customer through various supermarkets across different countries in Europe.

A schematic diagram of the supply chain is shown in Fig. 1 along with some of the data related to each stage of the supply chain. Detailed description of the operation of the main two echelons of the network; production and distribution, is presented next.

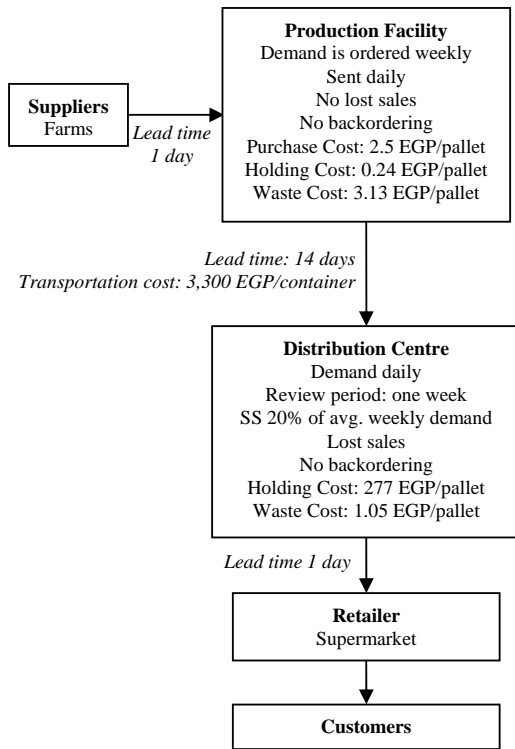

Fig. 1 A schematic diagram of the supply chain under study

B. Operational Data

Fig. 2 shows the product flow inside the production facility. The demand is weekly; hence, at the beginning of each week the producer receives an order from the distributor and consequently places a weekly order to the suppliers, who fulfil the order on daily basis throughout the week. The main advantage of placing orders weekly is to avoid loss of sales, since it takes the supplier 2 days to deliver the order.

After receiving the raw material (oranges) from the suppliers, they are washed, dried, and then loaded on a packing machine, which automatically packs them in pallets.

Inspection process is done by the quality control team and products that don't pass the inspection are either sold in open markets or disposed based on their level of quality. On the other hand, items that pass the inspection process are stored in temperature controlled storage area until the daily container trucks arrive to transport them to the distributor.

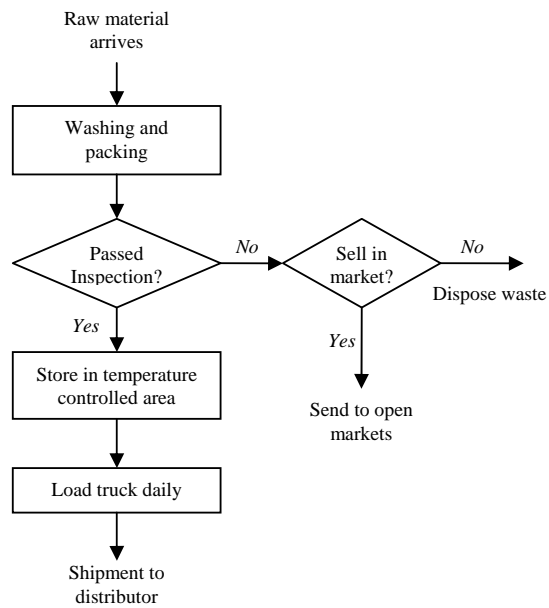

Fig. 2 Production facility process chart

Fig. 3 shows the distributor facility processes. The product is sent according to a first in first out (FIFO) allocation policy due to the product's perishability. When an order is received an inspection is done before it is sent to the retailer to check the remaining life time.

Products with a remaining lifetime less than 8 days are considered perished and are disposed. Products passing the inspection stage are sent to the retailer on the same day. The unsatisfied demand is lost.

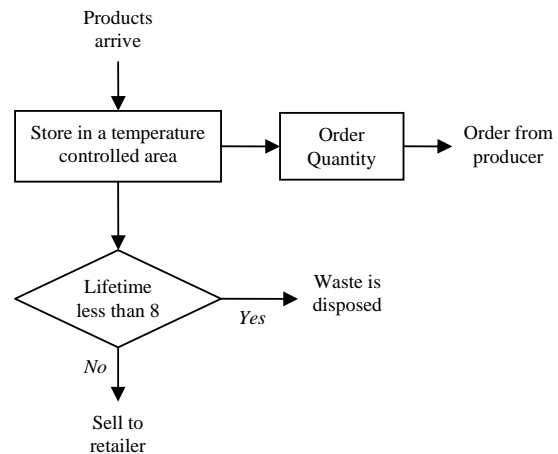

Fig. 3 Distributor facility process chart

C. Numerical Data

The data has been collected by interviews, actual visits to the facility, and from records of the past season. Data needing distribution fitting, like demand, has been fitted using StatFit software and the best ranked distribution has been selected.

The transportation lead time between producer and

distributor is fixed at 2 weeks. The cost of each container is 3,300 EGP.

The daily demand at the distributor has a Poisson distribution with a mean of 19.4. The distributor adopts a periodic review policy with a review period of one week with a safety stock of 20% of the average demand. The order quantity is calculated by adding the demand during lead time and 10% extra and the safety stock. Perished products are disposed at a cost of 1.08 EGP/pallet. The unsatisfied demand is lost. Inventory holding cost is 277 EGP/pallet. A summary of the most important numerical data collected used in this study is presented in Table I.

TABLE I
SUMMARY OF COLLECTED DATA

Parameter	Value
Lifetime	6 weeks
Stock out policy at producer	No lost sales
Backordering policy at producer	No backordering
Stock out policy at distributor	Lost sales
Backordering policy at distributor	No backordering
Distributor lead time	14 days
Number of Kilograms in a pallet	1.25 Kg
Number of pallets in one container	20 pallets
Cost of shipping one container	3,300 EGP
Daily demand at distributor	Poisson (19.4)
Purchasing cost/unit	2.5 EGP/ kg
Production inventory holding costs	0.24 EGP/pallet
Distributor inventory holding costs	1.9 EGP/pallet
Waste cost at producer	3.13 EGP/pallet
Waste cost at distributor	1.05 EGP/pallet
Cost of selling in open market	1.03 EGP/pallet

IV. MODEL DEVELOPMENT

This section aims at describing the main elements used for developing the simulation model. The model has been built in the ExtendSim™ Suite v8.0.2 simulation environment from ImagineThat, Inc.

A. Model Assumptions

A number of simplifying assumptions have been made in order to construct a simulation model for the supply chain under study.

These assumptions are as follows:

1. The products are assumed to arrive in pallets rather than in kilograms.
2. Setup and order costs are neglected.
3. The transportation of the work-in-process inside both facilities is neglected since they are just a few seconds.
4. Products are processed at each node according to First-In-First-Out (FIFO) rule; no job prioritization is considered.
5. An unlimited number of containers are available for shipping.
6. No stock outs occur at the production facility.
7. The transportation time from the producer to the distributor is deterministic and is equal to 14 days.
8. The holding cost is assumed to be just the cost of cooling.

9. The inspection process in the distribution facility is assumed to be done for every pallet; however, in real life they just take a sample from each container arriving.
10. Products are perishable; they have to be produced, transported, and sold; while still having a remaining lifetime of 7 days.
11. No backorders allowed for both producer and distributor.

B. Building the Model

The orders are sent weekly from the distributor to the producer, the economic order quantity (EOQ) (1) is calculated as function of the on hand inventory (*onhand*), demand during lead time (D_l), and the safety stock (*ss*).

Safety stock (2) is calculated as a fixed percentage of weekly demand (D_w). Fig. 4 shows a snapshot from the model where the EOQ is calculated.

$$EOQ = D_l + 0.1D_l + ss - onhand \quad (1)$$

$$ss = 0.2D_w \quad (2)$$

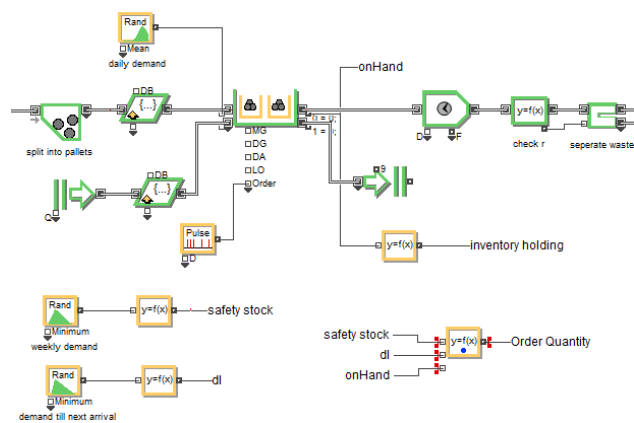

Fig. 4 Snapshot of where EOQ was calculated

After the demand occurs the products are inspected before leaving the facility. Remaining shelf life is checked; pallets with remaining shelf life less than 7 days are considered waste and the remaining units are sent to retailers. Fig 5 shows a snapshot of the model where this check happens.

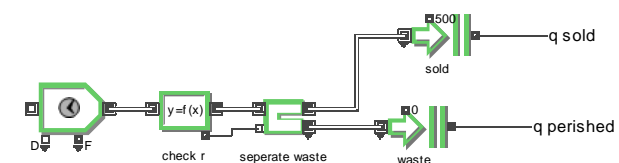

Fig. 5 Snapshot of where Remaining shelf life is checked

C. Calculating Different Cost Components

The different cost components have been defined in the model using a number of equations. The number of purchased units is reported and is used to calculate the purchasing cost C_p (3); where, q is the quantity purchased, c is the cost per kg, and n is the number of kg in a pallet.

$$C_p = q.c.n \quad (3)$$

The waste at both facilities C_w (4) is also calculated; where,

C_{wp} is cost of waste at the production facility (5) and C_{wd} is the cost of waste at the distribution facility (6), q_w is the quantity wasted at production facility, $q_{perished}$ is the quantity perished at the distribution facility, and c_d is the cost of disposing the waste at the distributor.

$$C_w = C_{wp} + C_{wd} \quad (4)$$

$$C_{wp} = q_w \cdot c_n \quad (5)$$

$$C_{wd} = q_{perished} \cdot c_d \quad (6)$$

The cost selling to the open market C_{op} (7); where, q_{op} is the quantity sold in open market, c_f is the fraction of its original cost representing the salvage value in this case.

$$C_{op} = (1 - c_f) q_{op} \cdot c_n \quad (7)$$

The numbers of units stored at the producer and at the distributor are also reported from the model and are used to calculate the inventory holding cost C_h (8). Where, H_p is the holding at the production facility (9), H_d is that of the distribution facility (10), cc_p is the cooling cost at the production facility, I_p is the amount of inventory at the producer, cc_d is the cooling cost at the distribution facility, and I_d is the amount of inventory at the distributor.

$$C_h = H_p + H_d \quad (8)$$

$$H_p = I_p \cdot cc_p \quad (9)$$

$$H_d = I_d \cdot cc_d \quad (10)$$

In (11) the transportation cost C_t is calculated based on the number of containers shipped that is reported from the model. Where, N is the number of containers shipped and c_s is the cost of shipping one container.

$$C_t = N \cdot c_s \quad (11)$$

Finally, the total cost TC (12) is the sum of purchasing cost C_p , cost of waste at both facilities C_w , cost of selling to the open market C_{op} , inventory holding cost C_h , and transportation cost C_t .

$$TC = C_p + C_w + C_{op} + C_h + C_t \quad (12)$$

D. Verification and Validation

Verification is concerned with ensuring that the model is working properly and that the operational logic is correct; in other words debugging the software. Animation has been used to study the routing of the products and ensuring that is done as intended. Also, the different equation blocks; specifically, the ones for calculating the different costs, has also been checked to make sure that it is reporting the correct values.

Validation is concerned with proving that the model is an accurate representation of the system. The output results of the base model (as-is model) are compared with the actual system results gathered from the past year records. Furthermore, the sensitivity of the outputs to the change in the inputs applied is tested. Finally, the model results are discussed with top management who confirmed the validity of the model.

V. EXPERIMENTATION, RESULTS, AND ANALYSIS

This section discusses the results of the performance of the system under study. It shows how the developed simulation

model helps in analysing this system's performance and finding out ways to improve that performance.

A. Measuring the Performance

In order to judge system's performance a number performance measures are used for evaluation. These are collected in the model using a plotter that presents the results in a graphical and tabular form. The outputs collected are:

1. The average purchasing cost/day.
2. The average cost of waste per day at both facilities.
3. The average cost of selling in open market/day.
4. The average holding cost of inventory in both facilities.
5. The average transportation cost/day.
6. The average Total cost/day.

Reported values of these measures, presented in the following sections, are average values based on a replication length of one year, 20 replications, and a warm up period of two months.

B. Base Model Results and Analysis

This section presents the results of the base model (as-is model) of the supply chain under study. The results of this scenario are summarized in Table II. The costs show that the greatest cost is that of the inventory holding cost. It is clear that we can decrease cost by decreasing the inventory at the distributor facility and increase the performance by decreasing both waste and perished products at both facilities.

The Percentage of total waste is 15.5% of the purchased pallets where most of it is at the distributor; the percentage of perished products alone is 11.9% of the purchased pallets, the lost sales percentage from the demand is 11.5%.

TABLE II
SCENARIO I RESULTS

Performance Measure (EGP/day)	Average
1. Purchasing cost C_p	103.80
2. Waste at both facilities C_w	8.97
3. Selling to the open market C_{op}	4.92
4. Inventory holding cost C_h	181.93
5. Transportation cost C_t	5,033.31
6. Total cost TC	5,332.92

C. Proposed Scenarios Results and Analysis

Based on analysis of the base model output; different scenarios are proposed to study the effect of changing the order quantity on the different cost items presented earlier. Different safety stock levels are tested; specifically, 15%, 10%, 5%, and 0% (indicating no safety stock).

The average total cost in EGP per day are plotted against the different stock levels as shown in Fig. 6; where, safety stock level of 20% represents the base model.

It is clear that the average total cost reaches its minimum value at 10% safety stock.

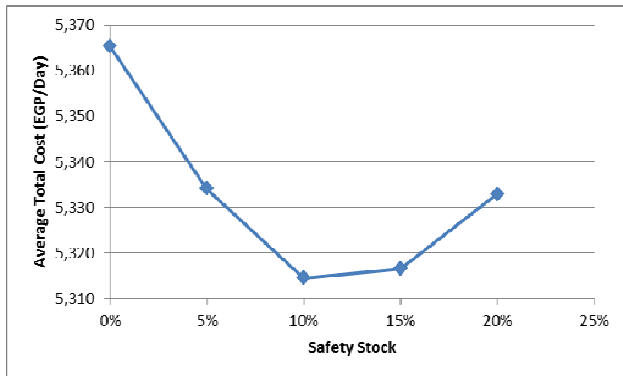

Fig. 6 Average total cost versus safety stock levels

Furthermore, the improvements calculated for each cost item is presented in Fig. 7. Positive improvement percentages means the reductions in cost when using a safety stock of 10% compared to 20% of the base model. It is clear from the figure that the highest reductions in cost is that of the inventory holding cost and waste cost at both facilities. However, purchasing cost increased slightly as well as selling to open market and transportation costs. Yet, the net effect of this decrease and increase in costs resulted in an overall decrease of total cost by 0.34%.

It should be noted that although the percentage improvement is low; yet, this can be attributed to the high contribution of transportation cost in total cost.

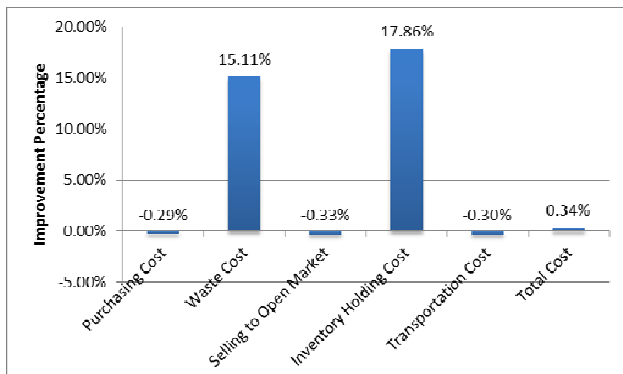

Fig. 7 Percentage improvement for each cost item

VI. CONCLUSIONS AND RECOMMENDATIONS

This model can be applied in any agri-food supply chain and further complexities can be done on it by assuming a variable lead. Adding different products with different lifetime, considering the order at producer from suppliers, adding more than one distributor, considering the retailer's inventory model to make it a three echelon supply chain model, are possible future extensions of the model.

Furthermore it is suggested to optimize the economic order quantity to decrease costs, increase performance and decrease waste.

ACKNOWLEDGMENT

The models developed for this work are built using the ExtendSim™ Suite v8.0.2 simulation environment from ImagineThat, Inc. The tool has been offered to the department of Industrial and Management Engineering, AASTMT, as a grant for teaching and research purposes as part of the ExtendSim Adopter Program.

REFERENCES

- [1] V. Salin, 1998. Information technology in agri-food supply chains. *International Food and Agribusiness Management Review*, (1998) 329–334.
- [2] J.D. Kinsey, 2001. The new food economy: Consumers, farms, pharms and science. *American Journal of Agricultural Economics*, Vol.83 (2001) 1113–1130
- [3] T. Heller, Sales grow so does competition, *Progressive Grocer*, Vol. 81 No. 10, (2002) 103-106.
- [4] G. De Sensi, F. Longo, G. Mirabelli, Inventory policies analysis under demand patterns and lead times constraints in a real supply chain. *International Journal of Production Research*, (2008) 6997-7016.
- [5] Rob A.C.M.Broekmeulen, Karel H.van Donselaar, A heuristic to manage perishable inventory with batch ordering, positive lead-times, and time varying demand. *Computers & Operations Research*, Vol 36 (2009) 3013-3018
- [6] Xiao Yong-bo, CHEN Jian, XU Xiao-linC, Fresh Product Supply Chain Coordination under CIF Business model with long distance transportation. *Systems Engineering — Theory & Practice*, (2008) 19-34.
- [7] Junxiu Jia, Qiyang Hub, Dynamic ordering and pricing for a perishable goods supply chain. *Computers & Industrial Engineering*, Vol. 60 (2011) 302-209
- [8] K. Sari, Inventory inaccuracy and performance of collaborative supply chain practices. *Industrial Management & Data systems*, Vol. 108 No. 4 (2008) 495-509.
- [9] Sandra Transchel, Stefan Minner, Periodic review inventory-control for perishable products under service level constraints. *OR Spectrum*, Vol.32 (2010) 979-996.
- [10] Aiyong Rong, Renzo Akkerman, Martin Grunow, An optimization approach for managing fresh food quality throughout the supply chain. *International Journal of Production Economics*, (2009)
- [11] Yong He, Shou-Yang Wang, K.K. Lai, An optimal production-inventory model for deteriorating items with multiple market demand. *European Journal of Operational Research*, Vol.203 (2010) 593-600.
- [12] Francis Vanek, Yao Sun, Transportation versus perishability in life cycle energy consumption: A case study of the temperature-controlled food product supply chain. *Transportation Research Part D*, (2008) 383-391.
- [13] Silpa Sagheer, S.S. Yadav, S.G. Deshmukh, Developing a conceptual framework for assessing competitiveness of India's agri food chain. *International Journal of Emerging markets*, Vol 4 (2009) 137-159.
- [14] Randy Stringer, Naiqan Sang, Andre Crpoenstedtn, Producers, Processors, and Procurement Decisions: The Case of vegetable supply chain in china. *World Development*, Vol. 37 No. 11 (2009) 1773-1780.
- [15] P. Engseth, Food product traceability and supply network integration. *Journal of Business & Industrial Marketing*, (2009) 421–430.
- [16] M. Bevilacqua, F.E. Ciarapica, G. Giachetta, Business process reengineering of a supply chain and a traceability system: a case study. *Journal of Food Engineering*, Vol.93 (2009) 13-22.
- [17] Charles X. Wang, Scott Webster, Markdown money contracts for perishable goods with clearance pricing. *European Journal of Operational Research*, Vol.196 (2009) 1113-1122.
- [18] Supply Chain Council (2004), available at: www.supply-chain.org