

Simulation and Workspace Analysis of a Tripod Parallel Manipulator

A. Arockia Selvakumar, R. Sivaramakrishnan, Srinivasa Karthik.T.V, Valluri Siva Ramakrishna, B.Vinodh.

Abstract—Industrial robots play a vital role in automation however only little effort are taken for the application of robots in machining work such as Grinding, Cutting, Milling, Drilling, Polishing etc. Robot parallel manipulators have high stiffness, rigidity and accuracy, which cannot be provided by conventional serial robot manipulators. The aim of this paper is to perform the modeling and the workspace analysis of a 3 DOF Parallel Manipulator (3 DOF PM). The 3 DOF PM was modeled and simulated using 'ADAMS'. The concept involved is based on the transformation of motion from a screw joint to a spherical joint through a connecting link. This paper work has been planned to model the Parallel Manipulator (PM) using screw joints for very accurate positioning. A workspace analysis has been done for the determination of work volume of the 3 DOF PM. The position of the spherical joints connected to the moving platform and the circumferential points of the moving platform were considered for finding the workspace. After the simulation, the position of the joints of the moving platform was noted with respect to simulation time and these points were given as input to the 'MATLAB' for getting the work envelope. Then 'AUTOCAD' is used for determining the work volume. The obtained values were compared with analytical approach by using Pappus-Guldinus Theorem. The analysis had been dealt by considering the parameters, link length and radius of the moving platform. From the results it is found that the radius of moving platform is directly proportional to the work volume for a constant link length and the link length is also directly proportional to the work volume, at a constant radius of the moving platform.

Keywords—Three Degrees of freedom Parallel Manipulator (3 DOF PM), ADAMS, Work volume, MATLAB, AUTOCAD, Pappus - Guldinus Theorem.

I. INTRODUCTION

INDUSTRIAL robots were invented for developing mechanical systems, which would carry out tasks with ease and accuracy, normally ascribed to Human beings. Robot manipulators are basically classified in to Serial Manipulators (SM) and Parallel Manipulators (PM).

A. Arockia Selvakumar, Srinivasa Karthik.T.V, Valluri Siva Ramakrishna and B. Vinodh are with Mechanical Engineering Department, Sri Venkateswara College of Engineering, Chennai, India. (e-mail: aselvakumar@svce.ac.in, tvs_88@live.com, bvinodh_11@yahoo.co.in, shiva_unplugged@yahoo.com).

R. Sivaramakrishnan is with the Production Engineering Department, MIT Campus, Anna University, Chennai, India. (e-mail: srk@mail.mitindia.com).

Robots used in Industries are all general purpose manipulators. SMs have the advantage of sweeping large workspaces and dexterous maneuverability like human arm but their load carrying capacity is rather poor due to cantilever structure. Moreover, singularities [1, 2, 12, and 13] lead to a loss of the controllability and degradation of the natural stiffness of parallel manipulators. Thus, singularities make the limited workspaces of the manipulators even smaller.

For enlarging workspace and avoiding singularities, a Double PM has been designed by combining two parallel mechanisms with a central axis. The Double PM designed has a vertical shape with a common central axis in it to enlarge work space. This is used in propeller grinding to measure the surface of a casting blade and to grind the removal depth [14]. The HEXA robot [15] is modified to 321-HEXA [16] by rearranging their legs to solve the problem of forward kinematics in a closed form. To reduce those, a three DOF translational manipulator, called DELTA, has been designed with rotary actuators [17]. However, the major drawbacks of the PMs are limited workspace.

A. Definition of Parallel Manipulator

A PM typically consists of moving platform that is connected to a fixed base by several links. Generally, the number of links is equal to the number of degrees of freedom such that every link is controlled by one actuator and all the actuators are mounted near the fixed base. For this reason, PMs are sometime called as platform manipulators because the external load can be shared by the actuators. PMs tend to have a high load carrying capacity.

B. Mobility Equation

The degrees of freedom of the PM are mainly dependent on the number of links, which connect the moving platform and the fixed platform. In this paper, the links are connected by spherical joints to the moving platform on one end and the other end connected by pin joints to the half nuts. Half nuts are mounted on the lead screw which is actuated manually. Then the nut translates over the screw which in turn actuates the links. For finding DOF of the manipulator the following mobility equation (1) was used.

$$F = 6(n-j-1) + \sum_{i=1}^j f_i \quad (1)$$

where,

F - DOF of the mechanism

f_i - Number of DOF of i^{th} joint

j - Number of joints.

For this tripod mechanism $n=8$ (3 Rigid links + 3 nuts + 1 movable platform), $j = 9$ and $f_i = 3$ for each spherical joint and $f_i = 1$ for each revolute joint and a screw joint.

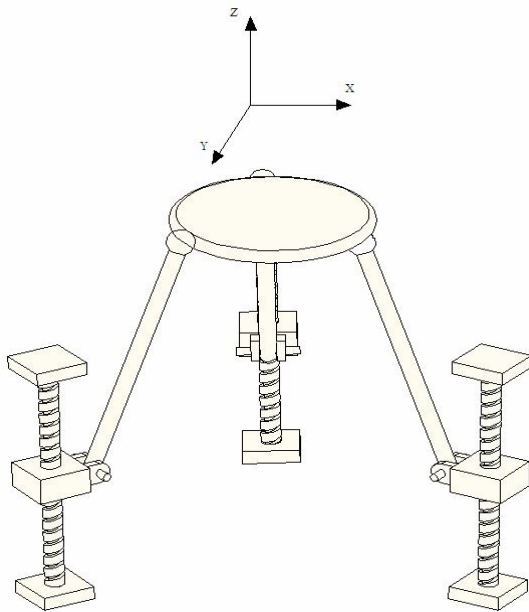


Fig. 1 A 3 – RPS Parallel Manipulator

Applying these in the equation (1.1), we get DOF, $F = 3$. Therefore the 3 DOF of the mechanism are,

- (1) Rotation about x-axis,
- (2) Rotation about y-axis and
- (3) Translation along z-axis.

II. KINEMATIC ANALYSIS OF 3 DOF PM

The fundamental problem of robot kinematics deals with mapping of vectors between two spaces namely Joint space (θ) and Cartesian space (x). Two co-ordinate systems are used to describe the position of the moving platform of the manipulator. One is global coordinate system (X, Y and Z) of the base plate and another one is local coordinate system (x , y and z) of the work plate. The kinematics [1, 9-11] also considers the motion conversion between spherical joints and pin joints. The ball joints are used to rotate the moving platform in any specified direction. The kinematic equation for finding the angle of tilt of moving platform is to be found in terms of link length, joint angles and the radius of the moving platform.

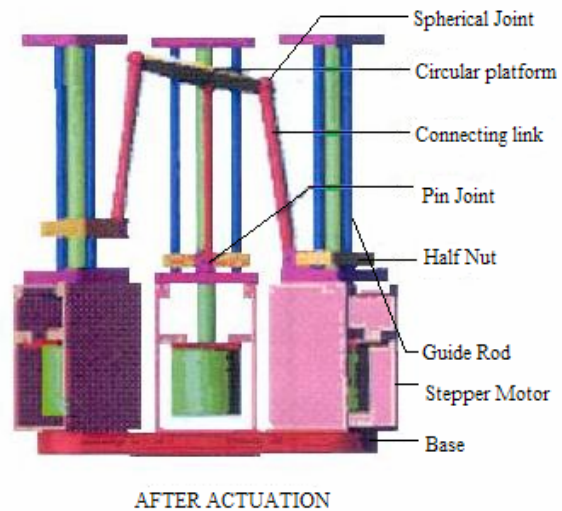


Fig. 1 An 'ADAMS' model of the 3 DOF PM

A program was written in 'C' language, for finding the angle of tilt of the moving platform by considering architectural parameters of the PM.

III. STEPS IN MODELING AND SIMULATION

The models have been built by building the physical attributes of the element or parts in the mechanical system using the rigid bodies and constraints. Constraints define how parts are attached to one another and how they are allowed to move relative to each other. Constraints restrict the relative movement between parts and represent idealized connections. After creating the model or at any point in the modeling process, one can run tests of model to ensure that it was created correctly and to verify in system characteristics. After initial simulations to determine the basic motion of model we must define the model by adding friction between bodies as linear or general state equations are used. It provides two optimization tests that help find the optimal design for the mechanical systems. These tests automatically run several simulations varying one or more modeling variables with each new simulation. Interactive simulations are the quickest and easiest way to perform a test on the model. It controls quickly run a single simulation and experiment with different simulation parameters and options. The scripted simulation provides access to the capabilities that are not available in the interactive simulation. Simulation scripts can do everything that the interactive controls can accept just by performing drag body operations.

IV. WORKSPACE ANALYSIS

A. Introduction

Workspace analysis is a specified problem in Direct Kinematics and it can be conveniently solved by formulating

input – output equations in a suitable form for easy repetitive calculations, which are needed to compute all the reachable positions and orientations of the moving platform. Workspace can be considered as the union of unit volumes, which have the same manifold geometry. For a PM, workspace is limited only because of the bounded range of the linear actuators, Mechanical limits on passive joints and Interference between links.

The workspace of the mechanism has been studied using different methods [3–6] e.g., geometric and numerical approaches. But most of them are related to the position workspace, which is a part of the workspace. In fact, the workspace can be divided into position workspace and orientation workspace for a manipulator with rotational capability. In order to analyze the performance of PMs with rotational DOF better, the orientation workspace should be studied.

B. Methodology

The positions of the spherical joints connected to the moving platform and the circumferential points of the moving platform considered for finding the workspace. Simulation of PM is done by the 'ADAMS' software. The position of the joints and the moving platform are noted with respect to simulation time. Then these points are given as input to the 'MATLAB' software for getting the work envelope and later to 'AUTOCAD' package for determining the work volume.

C. Optimization of workspace volume

The workspace of a parallel manipulator is one of the most important aspects to reflect its working capacity and it is necessary to analyze the shape and volume of the workspace for enhancing applications [7, 8] of PMs. The disadvantage of PM when compared to SM is that, it has a smaller workspace volume. And the architectural parameters such as link length and radius of the moving platform found to have a scaling effect over the workspace volume of the PM. The study proved that the increase in link length and decrease in the radius of the moving platform increases the workspace volume and vice versa.

D. Analytical approach

This approach is done to determine the workspace volume of the moving platform analytically. Knowing the platform radius (r) and angle of tilt (θ), the volume is determined using the Pappus - Guldinus theorem.

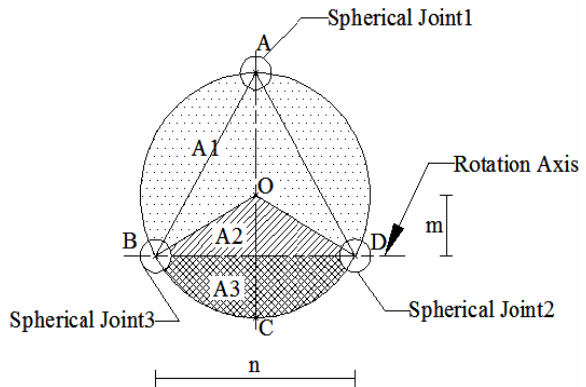


Fig. 2 Schematic representation of moving platform

Workspace Analysis of the PM was done using "MATLAB" and the profile of different parts of the moving platform are shown below.

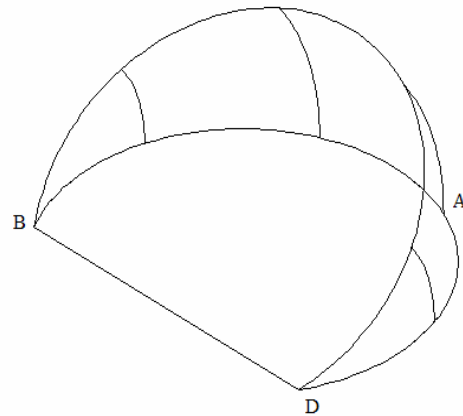


Fig. 2 (a) [BAD]

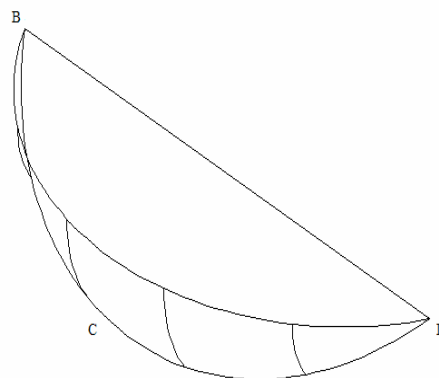


Fig. 2 (b) [BCD]

The circle ABCD of Fig 2 represents the moving platform of the PM. In this approach the total surface is divided into two separate regions to calculate their area and Centroid as shown in Fig 2 (a) and (b). By Using Pappus-Guldinus theorem, consider the region BAD,

$$\text{Area} = A1 + A2$$

$$= \alpha \times r^2 + (m \times n) / 2$$

where,

- α = Angle intended by the sector (deg),
- r = Radius of the moving platform (mm),
- m = Height of the triangle (mm),
- n = Base length of the triangle (mm),
- $A1$ = Area of DAOB (mm²),
- $A2$ = Area of OAB (mm²),

$$\text{Centroid} = \{A1 (2r \sin(\alpha) / (3\alpha)) + A2 (m/3)\} / (A1 + A2)$$

Similarly Region ABC,

$$\text{Area} = A1 - A2,$$

$$A1 = \text{Area of OACB (mm}^2\text{),}$$

$$A2 = \text{Area of OAB (mm}^2\text{),}$$

$$\text{Centroid} = \{A1 (2r \sin(\alpha) / (3\alpha)) - A2 (m/3)\} / (A1 - A2)$$

Distance traveled by Centroid (mm)

$$= (\theta / 360) / \pi \times 2 \times \pi \times R$$

$$\theta = \text{Angle of tilt of the moving platform (deg)}$$

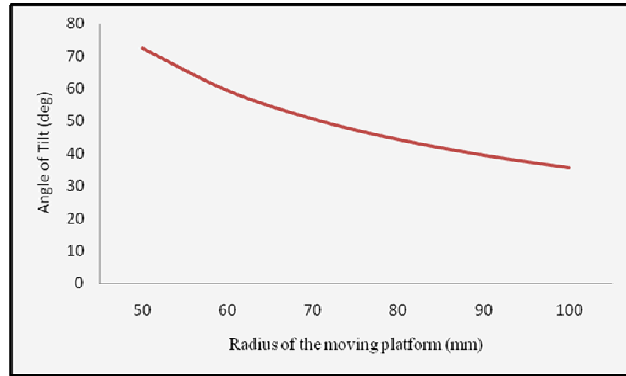
$$R = \text{Centroid distance}$$

$$\text{Work Volume} = \text{surface area of the moving platform} \times \text{Distance traveled by its Centroid (mm}^3\text{)}$$

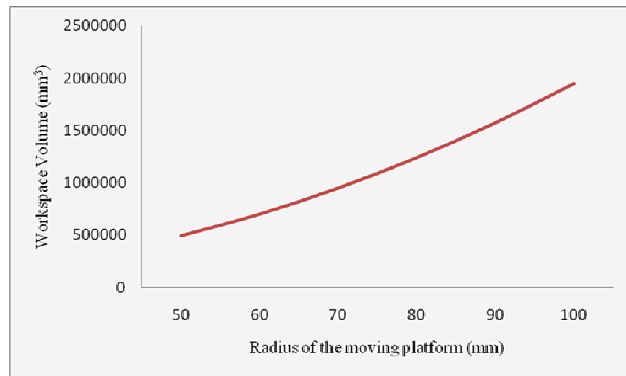


Fig. 2 A model of the 3 DOF Parallel Manipulator

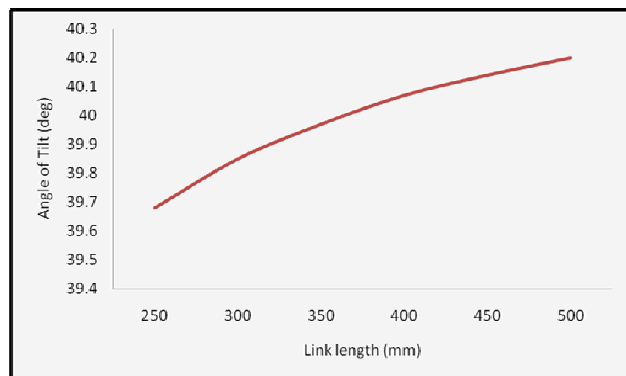
V. GRAPHS



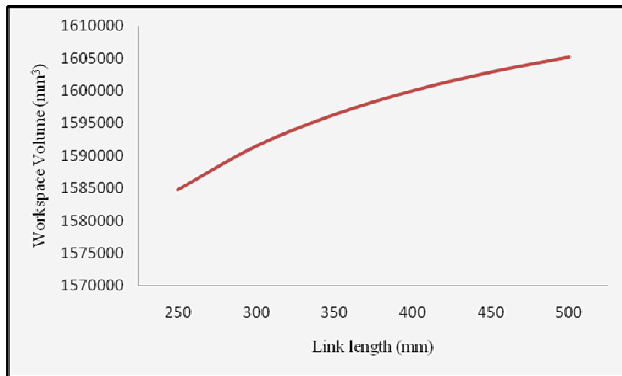
Graph 1 Radius of moving Platform Vs Angle of Tilt of the platform



Graph 2 Radius of moving Platform vs Work Volume



Graph 3 Link length vs Angle of Tilt of the platform



Graph 4 Link length vs Work Volume

VI. RESULTS AND DISCUSSION

When the radius of moving platform is increased from 50 to 100 mm, the work volume also increases from 702054.25 mm³ to 1949195.06 mm³ i.e., 64% increase even though the angle of tilt decreases from 59.338⁰ to 35.585⁰ i.e., 40% decrease for a constant link length of 200 mm. But when the link length is increased from 250 to 500 mm, the work volume increases from 1584780.02 mm³ to 1605223.976 mm³ along with which the angle of tilt also increases from 39.688⁰ to 40.2⁰ for a constant radius of 90 mm. ADAMS was found to have an average mean deviation of 3.16 % for 90 mm radius of moving platform from the analytical method.

From the results, for every 50 mm increase in link length, the work volume increases by an average of 10.4 % and for every 10 mm increase in radius of the moving platform, the work volume increases by an average of 23.86%.

VII. CONCLUSION

Workspace analysis has been dealt in detail and it was found that the link length and radius of moving platform have a scaling effect over work volume. The increase in link length and the radius of the moving platform increases the workspace volume and vice versa. As the radius of moving platform is increased the work volume increases for constant link length and vice versa. And when the link length is increased the work volume increases for a constant radius of the moving platform and vice versa.

ACKNOWLEDGMENT

A. Arockia Selvakumar is very grateful to his Project supervisor, Dr. R. Sivaramakrishnan, Assistant Professor, Production Engineering Department, MIT, Chennai for his constant guidance and motivation throughout this work. Moreover, he thanks the faculty of MIT and SVCE, Chennai for the facilities they have made avail for them. He also thanks his co-Authors, Mr. Srinivasa Karthik.T.V, Mr. B. Vinodh, Mr. Valluri Siva Ramakrishna, SVCE Students, Mechanical Engineering Department, for their help.

Finally, all authors thank their Institution, Sri Venkateswara College of Engineering, Chennai for having provided this

opportunity, without whom they wouldn't have come this far.

REFERENCES

- [1] C. M. Gosselin and J. Angeles, "Singularity analysis of closedloop kinematic chains," *IEEE Trans. Robot. Autom.* **6**(3), 281–290 (1990).
- [2] J.Wu, J.Wang, T. Li and L.Wang, "Analysis and application of a 2-DOF planar parallel mechanism," *J. Mech. Design* **129**(4), 434–437 (2007).
- [3] F. Gao, X. Zhang, Y. Zhao and H.Wang, "A physical model of the solution space and the atlases of the reachable workspaces for 2-DOF parallel plane wrists," *Mech. Mach. Theory* **31**(2), 173–184 (1996).
- [4] X. J. Liu, J. S. Wang and G. Pritschow, "Kinematics, singularity and workspace of planar 5R symmetrical parallel mechanisms," *Mech. Mach. Theory* **41**(2), 145–169 (2006).
- [5] S. P. Bai, M. Y. Teo, W. S. Ng and C. Sim, "Workspace analysis of a parallel manipulator with one redundant dof for skull-base surgery," *IEEE International Conference on Intelligent Robots and Systems* (2001) pp. 1694–1699.
- [6] I. A. Bonev and C. M. Gosselin, "Analytical determination of the workspace of symmetrical spherical parallel mechanisms," *IEEE Trans. Robot.* **22**(5), 1011–1017 (2006).
- [7] Li, Y., and Xu, Q., 2005, "Kinematic Analysis of a New 3-DOF Translational Parallel Manipulator," *Proceedings of ASME 2005 International Design Engineering Technical Conferences and Computers and Information in Engineering Conference, DETC2005-84299*, Long Beach, California, Sept. 24–28,
- [8] 2. Li, Y., and Xu, Q., 2005, "Kinematic Design of a Novel 3-DOF Compliant Parallel Manipulator for Nanomanipulation," *Proceedings of IEEE/ASME International Conference on Advanced Intelligent Mechatronics*, pp. 93–98.
- [9] Jim Wook Kim and Park J.C (2000), "Direct Kinematic analysis of 3-PRS Parallel Mechanisms", Elsevier Publications, *Mechanism and Machine Theory*, Vol.35, pp.1121 – 1134.
- [10] Sivaramakrishnan R., Kalaichelvan K. And Dhanraj R. (2000), "Kinematics and construction of 3-DOF Parallel Manipulator", *Proceeding of International Conference on Intelligent Flexible Autonomous Manufacturing Systems (IFAMS 2000)*, pp.789-795.
- [11] Yangmin Li, Qingsong Xu (2006), "Kinematic Analysis and Design of a New 3-DOF Translational Parallel Manipulator", Vol.128 in *Journal of Mechanical Design*, pp - 729-734.
- [12] I. A. Bonev, D. Zlatanov and C. M. Gosselin, "Singularity analysis of 3-DOF planar parallel mechanisms via screw theory," *ASME, J. Mech. Design*, **125**(3), 573–581 (2003).
- [13] D. Zlatanov, R. G. Fenton and B. Benhabib. "Identification and classification of the singular configurations of mechanisms," *Mech. Mach. Theory* **33**(6), 743–760 (1998).
- [14] Ki lee and Kun Woo park, "Kinematic and dynamic analysis of a double parallel manipulator for enlarging workspace and avoiding singularities", in *IEEE Transactions on robotics and Automation*, December 1999, Vol. 15, no.6, pp 1024-1034.
- [15] Pierrot, Fournier and Dauchez, "Toward a fully parallel 6-DOF robot for high speed applications," in *IEEE Transactions on robotics and Automation*, Feb.1992, vol.7, pp. 15-22.
- [16] H. Bruyninckx, "A fully parallel manipulator with closed form position and velocity kinematics," in *Proc. IEEE int. Conf. Robot. Automation*, Albuquerque, NM, Apr.1997, pp. 2657-2662.
- [17] R.Clavel, "DELTA, a fast robot with parallel geometry," in *Proc. 18th int. Symp. Industrial Robot*, Lausanne, Switzerland, Apr. 1988, pp. 91-100.



A. Arockia Selvakumar received M.E in Computer Aided Design from Anna University, TamilNadu, India in 2004. He is currently pursuing a Ph.D degree in the field of Parallel manipulators in Madras Institute of Technology, Chennai which includes Parallel mechanism design and its application for machining work.



Dr.R.Sivaramakrishnan received his M.E degree in Production Engineering and Ph.D in the field of Parallel manipulators from the Madras Institute of Technology, Anna University, TamilNadu, India. His research background is also Parallel Manipulator, which includes the Tripod and the Triglide manipulator, Parallel Mechanism Design, surface grinding and its application for Machining Work.



Srinivasa Karthik.T.V is currently pursuing his B.E in Mechanical Engineering in Sri Venkateswara College of Engineering, Anna University, Chennai, TamilNadu, India and will complete his degree in the year 2010 May. His work experiences are in the fields Robotics (Parallel Manipulators), Engines (Study of Emission Control, BioFuels), Material Sciences (Study of Vibration Characteristics of Fiber Reinforced Plastics, Manufacturing and testing of Carbon Fiber Composites).



Valluri Siva Ramakrishna is currently pursuing his B.E in Mechanical Engineering in Sri Venkateswara College of Engineering, Anna University, Chennai, TamilNadu, India and will complete his degree in the year 2010 May. His work experiences are in the fields of Robotics (Parallel Manipulators) and Material Science (Study of Vibration Characteristics of Fibre Reinforced Composites).



B. Vinodh is currently pursuing his B.E in Mechanical Engineering in Sri Venkateswara College of Engineering, Chennai, Anna University, Chennai, TamilNadu, India and will complete his degree in the year 2010 May. His work experiences are in the fields of Robotics (Parallel Manipulators) and Engines (Study of Emission Control, Effects of BioFuel on Emission).