

Rock Thickness Measurement by Using Self-Excited Acoustical System

Janusz Kwaśniewski, Ireneusz Dominik, Krzysztof Lalik

Abstract—The knowledge about rock layers thickness, especially above drilled mining pavements is crucial for workers safety. The measuring systems used nowadays are generally imperfect and there is a strong demand for improvement. The application of a new type of a measurement system called Self-excited Acoustical System is presented in the paper. The system was applied until now to monitor stress changes in metal and concrete constructions. The change in measurement methodology resulted in possibility of measuring the thickness of the rocks above the tunnels as well as thickness of a singular rock layer. The idea is to find two resonance frequencies of the self-excited system, which consists of a vibration exciter and vibration receiver placed at a distance, which are coupled with a proper power amplifier, and which operate in a closed loop with a positive feedback. The resonance with the higher amplitude determines thickness of the whole rock, whereas the lower amplitude resonance indicates thickness of a singular layer. The results of the laboratory tests conducted on a group of different rock materials are also presented.

Keywords—Autooscillator, non-destructive testing, rock thickness measurement.

I. INTRODUCTION

AMONG the most important features, safety of workers in mines and in every type of activities involving tunnel building and its exploitation is one of the basic requirements. One of the crucial operation is the assessment of the type and thickness of rock layers above tunnels.

The simplest method of the rock assessment is traditional drilling which involved extracting, examining and testing a limited number of core samples. The obtained material is the best indicator of the rock state and layer thickness. Unfortunately, the drilling, by its nature, is only the punctual rock examination. The high cost and slow pace associated with drilling during creating the whole net of examined points has prompted the researchers to investigate other low cost, fast and efficient non-destructive techniques (NDT).

The most common NDT techniques are ultrasound methods. A typical pulse-echo hardware configuration is mostly used where the energy is introduced by an emitter and propagates through the materials in the form of waves. The signal delay time can indicate the layer's thickness. Thickness measurement is best obtained by placing the receiver and transmitter probes in close proximity on a clean surface and applying with the broadband input [1]. That is why in many cases the usage of the system in a real underground

environment is troublesome. The ultrasonic techniques are also used in mines to control thickness of shotcrete – the concrete placed with high velocity on the rock mass to support it. The use of shotcrete in hardrock mines has increased substantially during the last decade. Large shotcrete thickness variations are caused by the irregular rock mass surface, which is bound to induce considerable thickness variations over large spans in an underground tunnel [2]. The measurement method is a seismic technique based on the analysis and interpretation of propagating transient stress waves. In particular, the velocity and frequency of the P- and S-waves are critical to the success of this method due to their dependence to the properties of the examined material. However, the problem is to measure their speed (about 5000 m/s) [3]. The wave flight (transition) times measure requires a nanosecond accuracy and as a result, a very sophisticated apparatus is necessary.

Among other methods the gravity method is also quite well known. Sets of diagrams of the normalized peak gravity effect of exposed rock bodies can be used to determine the depth or thickness of rock [4]. The advantage of the method is applicability to any shape rock bodies but the measurement signal can be easily noised by environment conditions.

An interesting method of using a radar coal thickness sensor deserves should be also presented. The non-contacting electromagnetic technique uses spatial modulation created by moving a simple sensor antenna along each axes whereas the complex reflection coefficient is measured. Measurements made of coal, rock, concrete, granite, and salt have shown that the technique can measure thickness up to 1.5m with high accuracy; however, it cannot be used at the moment for longer distances [5].

As an alternative method of assessing the rock thickness we propose the Self-excited Acoustical System which has been developed at the Department of Process Control at the AGH University of Science and Technology in Poland [6], [7]. The preliminary research of the system has proven its high measurement sensitivity.

II. PRINCIPLES OF SELF-EXCITED ACOUSTICAL SYSTEM

The principle of the Self-excited Acoustical System (SAS) is based on the self-excitation phenomena. A vibration emitter and a vibration receiver are placed in a distance, and are coupled with a proper power amplifier, which operate in a closed loop with a positive feedback. This causes the excitation of the system. The change of velocity of wave propagation, which is associated with the change of the resonance frequency in the system, is caused by the deformation of the examined material. Stress changes manifest

J. Kwaśniewski, I. Dominik, and K. Lalikis are with the AGH University of Science and Technology, Faculty of Mechanical Engineering and Robotics, Department of Process Control, Krakow, Poland (e-mail: kwa_j@agh.edu.pl, dominik@agh.edu.pl, klalik@agh.edu.pl).

themselves in small but detectable variations of frequency. In the previous articles the system was used to assess the stress changes in materials: sandstone, concrete, steel [6], [7]. The SAS system allows to operate in the range of a dozen or so kHz which is easily reached in practical applications.

The self-excitation phenomena are used also in devices named autooscillators. The principles of operating of an autooscillator can be presented by using a familiar doorbell, which can help to understand the principles of the SAS system. A doorbell is one of the simplest systems where self-excited vibrations are created. As every autooscillator it consists of three main parts: energy source, oscillating system and control valve of energy supply. In the case of a doorbell a source of energy can be a battery, the oscillating system consists of a movable part hitting a bell whereas a control valve is a coil with its armature (Fig. 1). Between the oscillating system and controller the positive feedback loop is created. The main function of this feedback is to supply the energy to the system to cover the energy dissipation. As the result the movable bell part realizes the steady-state self-excited vibrations which last as long as the energy is supplied.

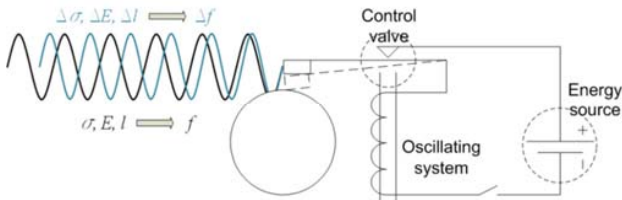

Fig. 1 Electric doorbell as an example of self-excited system

Similarly to the doorbell, the presented SAS system is subjected to the self-excited phenomena in which the resonance frequency is reached. The frequency depends mainly on the examined material property such as Young's modulus E , the stress level σ or the sample length l . The change of one of those parameters will result in changing the resonance frequency of the SAS system.

Fig. 2 presents the SAS system scheme, where the emitter (E) is a piezoelectric shaker while the receiver (R) is a piezoelectric accelerometer. The acoustical wave is sent into a tested material by the shaker and received after some delay by the receiver. A conditioner and an amplifier are used adequately to condition and amplify the signal obtained from the receiver. The emitter, the conditioner and the amplifier with the shaker at the end create a positive feedback loop. The mechanical principles described in [9] allow to state that the longer is the delay time (wave flight, transition time) the lower resonance frequency is reached. The delay time is directly associated with the thickness of the tested material. It means that thicker tested material indicates the lower frequency of the system.

The main advantage of the SAS system in comparison to the classic ultrasonic systems is fact that it uses the close loop structure. That is why, from the whole spectrum of frequencies only one frequency is dominant and vibrations at this

frequency have amplitude much higher than the vibrations at the other frequencies. This way interpretation is much more convenient and reliably than in open loop ultrasonic systems.

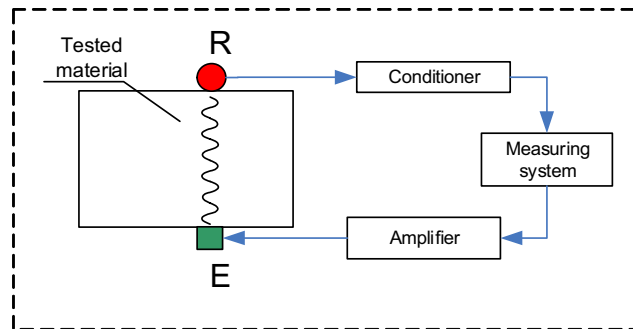

Fig. 2 The self-excited acoustical system scheme where: E- emitter and R – receiver

Moreover, the system can measure not only the total thickness of the tested material but also the thickness of the singular layer. In most of the cases the rock consists of different material layers. The wave propagating through the material reaches not only the receiver but also will be reflected by any of the surface of discontinuity which physically is the border between two layers [9], [10]. In the case of the SAS system they can be observed as a resonance peaks with smaller amplitude and frequency than the main peak but still easily distinguished from the rest of the frequency spectrum.

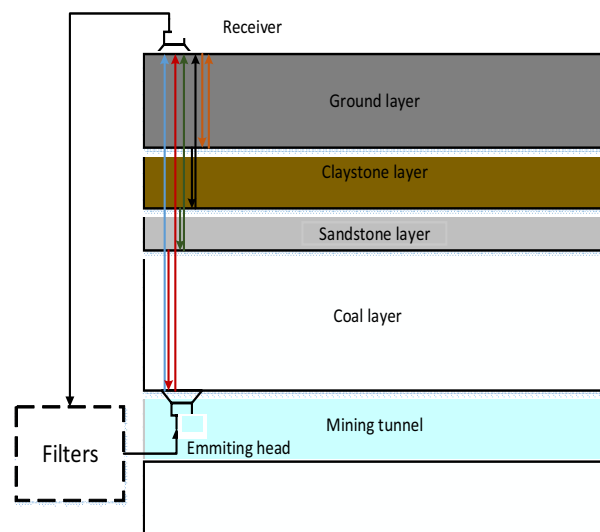

Fig. 3 The idea of the SAS system in layer thickness monitoring for shallow tunnels

As it was mentioned the delay time which depends on the thickness of particular layer is crucial for the resonance frequency. It is possible to calibrate the SAS system to focus on the particular layer by using band-pass filters, so the resonance frequency associated with the examined layer can be the dominant frequency of the system. In this way, the

calibrated system can monitor the selected layer thickness simply by moving the receiver and shaker along the given distance. For a drilled tunnel the described idea is presented in Fig. 3. Because of its nature, the self-excited system requires much less energy than the non-excited systems but still the possible maximum distance between the emitter and the receiver is to discover. At the moment the first tests carried on the monolith samples of 10m in diameter have proven the applicability of the proposed system at least for the tested range.

III. MEASURING STAND

The first laboratory tests were carried out on four different rock materials. In Fig. 4 the samples in a form of plates of yellow sandstone (right side) and oolite (sedimentary type rock – left side) are shown. At the beginning the sand stone sample of 25mm and oolite of 60mm thickness were placed singularly between the emitter and the receiver according to the diagram in Fig. 2. After this stage the samples were pressed together by clamps and examined by the SAS system. The first results have proven the theory that the thicker material results in measurement as the lower frequency of the self-excited system.

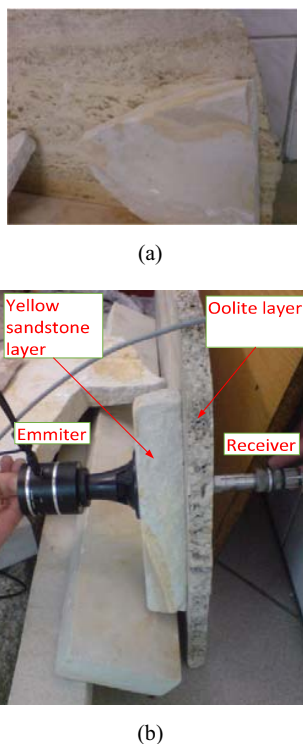

Fig. 4 Materials under examination with SAS system: (a) front view, (b) side view

The tests made on the coupled rocks confirmed that the wave reflection occurs in the frequency spectrum as the additional vibrations (peaks). They are in the lower frequency range and have much smaller amplitude in comparison to the

vibrations derived from the unreflected wave transmission (direct wave propagation between emitter and receiver).

The studies on the different materials were conducted in the next step. The material plates were made of marble and concrete. The experiments were carried out for variable thickness of the marble layer.

IV. RESULTS

In the first stage of the experiment conducted on coupled sandstone-oolite layer plates, three different signals showing the vibration accelerations in time domain were acquired as a result of measurements. The signals were transformed with Fast Fourier algorithm to the frequency domain showed in Fig. 5. The vibration measurement was made using a piezoelectric accelerometer without unit conversion; hence the amplitude unit is in volts not in m/s^2 .

For a single oolite sample, which was the thinner one, the obtained resonance frequency was 2198 Hz. For more than twice as thick single plate made of yellow sandstone, this frequency was 1980 Hz. The smallest frequency was measured for a coupled oolite-sandstone layers and was determined as 1427 Hz.

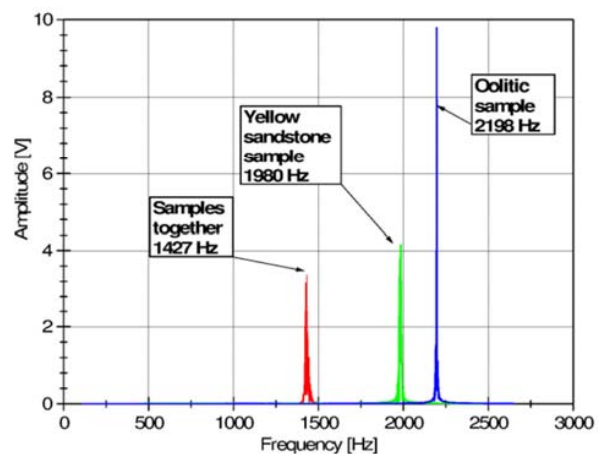

Fig. 5 FFT Frequency spectrum for three kinds of material using SAS system

The resonance peak related with the phase boundary reflection wave (between two layers) cannot be noticed in frequency spectrum with the linear ordinate axis because it has too small amplitude compared to the main resonance frequency peak (the direct wave propagation between the emitter and the receiver). That is why the logarithmic frequency spectrum for the signal obtained from two layers coupled oolite-sandstone plate is shown in Fig. 6.

The greatest advantage of self-excited systems applied in the rock layers thick measurement can be explained by the presented spectrum. The amplitude of the vibrations related to the main wave transmission is the only one magnified by the system. It is more than a hundred times larger than the magnitude of vibrations related to the transmission of the reflected wave. Also the third frequency can be marked in the

frequency spectrum - result of the upper material top wave reflection. The presence of three resonance peaks is easy to explain by the wave reflection phenomenon. The highest amplitude peak occurring at the frequency of 1427 Hz is associated with direct transmission of the acoustic wave. The second peak with a significantly lower amplitude and reduced frequency of 1087 Hz comes from the wave reflected at the oolite-sandstone phase boundary. The third peak is related to the reflection of the acoustic wave at the oolite-air phase boundary. We can conclude that this wave had to travel the longest distance to be registered by the receiver. The longest distance induces the longest delay - time of flight of the wave, and thus, the lowest frequency of the self-excitation.

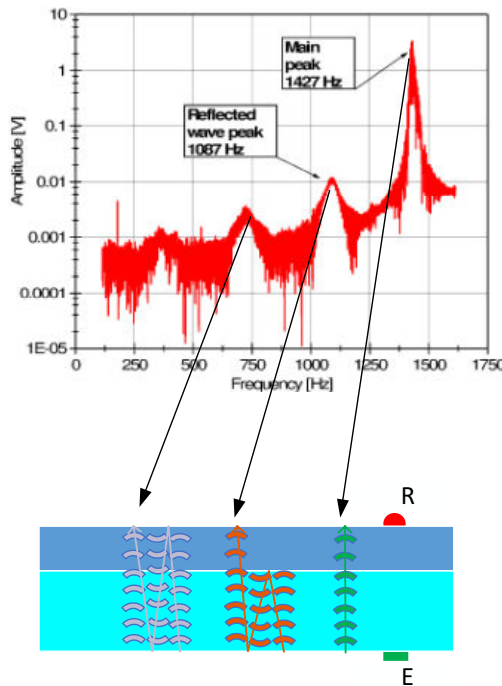

Fig. 6 Logarithmic FFT Frequency spectrum for coupled oolite-sandstone plates

The first stage of research proved that the SAS system can indirectly measure the rock single layer thickness. In the next step the tested materials were changed to marble-concrete layers. The studies were performed in two configurations with the thickness of the cement layer remained constant (200mm) while the thickness of the marble layer was changed. In the first configuration the marble layer was 80mm thick and then it was changed to 100mm. The measurement results are shown in Fig. 7.

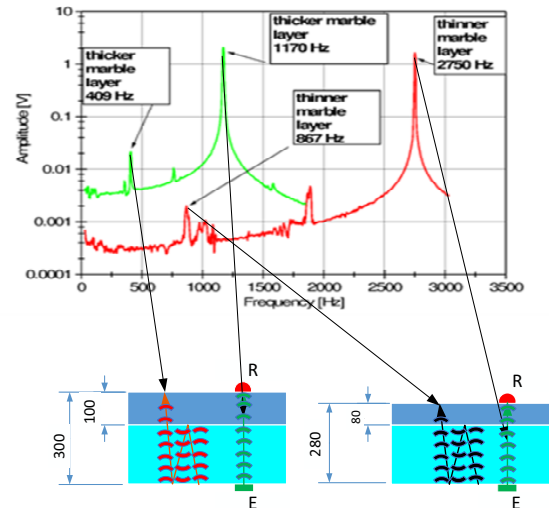

Fig. 7 FFT frequency spectrum for coupled concrete-marble material in two configuration of marble thickness

The frequency spectrum of the self-excited system presented in Fig. 7 clearly indicates the dominant amplitude of vibrations connected with the direct wave flight. It occurs at frequency of 2750 Hz for a thinner coupled layers (80mm marble and 200mm concrete), and 1170 Hz for the thicker sample (100mm marble and 200mm concrete). The resonance peaks induced by the wave reflections are also visible. They occur at frequencies of 409 Hz for the first set of layer thicknesses and 867 Hz for the second configuration. The change of the position of both peaks in both configurations, not just the smaller one related to the reflection wave, is associated with the total sample thickness increase: from 280 to 300mm.

V. MODELING

The construction of the emitter and the receiver of the SAS system were based on piezo-stack technology. The emitter was a piezoelectric actuator and the receiver was a piezoelectric accelerometer. Piezo-elements have the advantage of fast response, high precision and generation of large forces [8].

The actuating work of piezoelectric stack can be described by the constitutive equation (1)

$$\begin{cases} S = s^E T + dE \\ D = dT + \varepsilon^T E \end{cases} \quad (1)$$

where S is the strain tensor, s^E is the elastic compliance matrix, T is the stress tensor, d is the piezoelectric constant matrix, E is the electric field vector, D is the electric displacement vector and ε^T is the permittivity at a constant stress.

The model of a piezoelectric actuator can be simplified considering only one-dimensional lumped parameter behavior, so S , T , E and D would be scalar values.

The basic principle of a sensor operation is the piezoelectric effect, which occurs as electric charges during piezo-element

elastic deformation. Total electric charge Q stated by (2) is induced acting force F_x along electrical axis (longitude effect).

$$Q = k_p F_x \quad (2)$$

where k_p is a piezoelectric module for the accelerometer.

The frequency response of the piezoelectric accelerometer is determined by operation of mechanical system, which is a second order oscillator and the electrical system, which operates as a high pass RC filter. Transfer function $H(s)$ of the accelerometer is given thus by (3)

$$H(s) = \frac{U(s)}{X(s)} = \frac{k_p R C s}{(1 + R C s) \left(1 + \frac{2\zeta}{\omega_0} s + \frac{1}{\omega_0^2} s^2 \right)} \quad (3)$$

where R is the resistance and C is capacity of the electrical circuit, ω_0 is natural frequency of mechanical system and ζ is a damping ratio. The system input is acceleration X , and the system output is voltage U .

After obtaining mathematical model of the actuator and the sensor, the SAS system can be modeled by the scheme showed in Fig. 8.

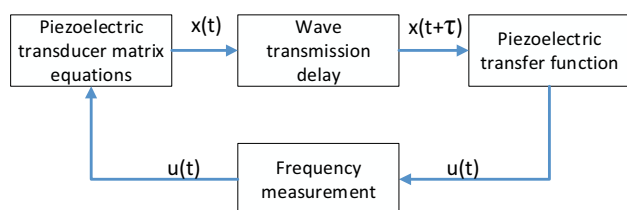

Fig. 8 Scheme of SAS system numerical model

The numerical model can be used to calculate the dependence between the time of flight delay τ and the frequency of the Self-excited Acoustical System.

VI. CONCLUSIONS

The studies over the Self-excited Acoustical System allow to conclude that thickness of a single layer in a multilayer rock body as well as the thickness of the whole multilayer rock structure itself can be measured indirectly by the frequency measurement. The general rule is to find the dominant frequency of the self-excited system associated with the direct acoustic wave transmission. This frequency will determine the total thickness of the layered rock. All the reflected waves will have a longer distance to flight, and consequently, the related resonance peaks will have much smaller amplitudes and reduced frequencies. In a case of determining the thickness of single layer in double - or multilayered rock, a researcher should find additional resonance peaks at frequencies lower than frequency of the dominant resonance peak, which would allow defining the thickness of each of these layers separately.

This paper presents the results of the laboratory research where the SAS system examined the layer thickness in yellow sandstone – oolitic coupled layers system as well as in marble and concrete configuration. The paper presents also

a simplified mathematical model for calculation of the resonance frequency of total and single layer thickness. The additional laboratory research to determine the material thickness in the function of the SAS resonance frequency will give results directly in length units by comparison the measurement and the model.

Application of the pass band filter in the positive feedback loop can solve the problem of selecting the appropriate resonance peak resulted from the wave reflection. Filters will allow the system to magnify the amplitude of the reflected vibrations from a single layer, and improve the interpretation of frequency spectrum results. Further research will focus on implementation of intelligent and autonomous filters based on fuzzy logic. At that moment the research on real rock structures will be considered.

ACKNOWLEDGMENT

The research work was supported by the Polish government as part of the research program No N N501 208140 conducted in the years 2011-2014.

REFERENCES

- [1] A. H. Onur, S. Bakrač and D. Karakuş, *Ultrasonic Waves in Mining Application*(Book style) ed. A. A. dos Santos, ISBN 978-953-51-0201-4, 2012.
- [2] T. A. Melby, "Sprayed Concrete for Rock Support," *MBT International Underground Construction Group*. 1994. 186 p.
- [3] P. Guevremont, F. P. Hassani, "Using NDT for Thickness Measurement of Shotcrete Rock Support Systems in Underground Mines," AIP Conference Proceedings, 2000, Vol. 509 Issue 1, p1701.
- [4] W. J. Johannes, W. Jacoby, P. L. Smilde, *Gravity Interpretation: Fundamentals and Application of Gravity Inversion*. Springer, 2009. ISBN 978-3-540-85328-2.
- [5] R. L. Chufo, "An Electromagnetic Noncontacting Sensor for Thickness Measurement in a Dispersive Media," U.S. Bureau of Mines, Pittsburgh, Pennsylvania. Proc AIAA/NASA Conference on Intelligent Robots in Field, Factory, Service, and Space, 1994, Jon D. Erickson, Houston, TX 1:190-194
- [6] J. Kwaśniewski, I. Dominik, J. Konieczny, K. Lalik., A. Sakeb, Application of Self-Excited Acoustical System for Stress Changes Measurement in Sandstone Bar, Journal of Theoretical and Applied Mechanics ; ISSN 1429-2955. — vol. 49 no. 4, 2011
- [7] J. Kwaśniewski, I. Dominik, K. Lalik, Application of Self-Oscillating System for Stress Measurement in Metal, Journal of Vibroengineering; ISSN 1392-8716. — vol. 14, 2012
- [8] V. I. Babitsky, V. K. Astashev, A. N. Kalashnikov: *Autoresonant Control Of Nonlinear Mode in Ultrasonic Transducer for Machining Applications*, ISSN 0041-624X, Ultrasonics., 2004
- [9] Weaver R. L., Lobkis O. I., Yamilov A., Entrainment and Stimulated Emission of Ultrasonic Piezoelectric Auto-Oscillators, Acoustical Society of America, 2007
- [10] S. Poklonskyi, *Ways to Improve the Definition of Soils Deformation Characteristics in Laboratory Conditions*, Advances in Soil Mechanics and Geotechnical Engineering, Volume 2: Proceedings of the 5th International Young Geotechnical Engineers' Conference, 2013