

Regional Medical Imaging System

Michal Javornik, Otto Dostal and Karel Slavicek

Abstract—The purpose of this article is to introduce an advanced system for the support of processing of medical image information, and the terminology related to this system, which can be an important element to a faster transition to a fully digitalized hospital.

The core of the system is a set of DICOM compliant applications running over a dedicated computer network. The whole integrated system creates a collaborative platform supporting daily routines in the radiology community, developing communication channels, supporting the exchange of information and special consultations among various medical institutions as well as supporting medical training for practicing radiologists and medical students. It gives the users outside of hospitals the tools to work in almost the same conditions as in the radiology departments.

Keywords—DICOM, Integration, Medical Education, Medical Imaging

I. INTRODUCTION

DISSEMINATION of medical knowledge, tools supporting and assisting in decision making and accessing relevant and accurate sources of information for scientific research, all enhance the synergy among the medical community and play a very important role in healthcare and consequently bring benefits to all people, particularly the community served. New strategies and new telemedicine scenarios must be introduced not only amongst local radiology departments but also at the regional and global level [13, 23]. The strategies must therefore take into consideration local as well as regional and even global aspects. A successful system must be fully integrated into systems that support daily routine procedures as well as integrate into other technologies related to medicine [7]. The digital environment, from its very beginning, delivers its users many advantages such as increased efficiency, cost savings and in particular enhances the quality of medical care. Similar large-scale systems improving operation-efficiency and cost-effectiveness in the delivery of healthcare have been formed around the world. The first step is to compare the traditional radiology centre, so called film-based, to the advantages of a digital environment that supports medical image information processing. Many large-scale healthcare enterprises have been formed around the world. The possibilities of current ICT enable them to operate in a very efficient and cost effective manner even if they are spread over a very large area [3, 20].

M. Javornik is from the Masaryk University, Brno, Czech Republic. He is now in the Institute of Computer Science, area of medical applications, (phone: +420-549493348; e-mail: javor@ics.muni.cz).

O. Dostal is from the Masaryk University, Brno, Czech Republic. He is now in the Institute of Computer Science, area of computer networks in medicine, (phone: +420-549494133; e-mail: otto@ics.muni.cz).

K. Slavicek is from the Masaryk University, Brno, Czech Republic. He is now in the Institute of Computer Science, area of computer networks, (phone: +420-549496831; e-mail: slavicek@ics.muni.cz).

Many designs, pilot studies and full implementations are underway in Europe as well as in the United States and Asia. Image distribution by specially configured dedicated computer networks plays the key role in the implementation of telemedicine.

II. RELATED TERMS AND STANDARDS

A. PACS and DICOM Standard

PACS (Picture Archiving and Communication System) is a system that streamlines image distribution, delivers relevant medical images and other related data, including reports describing medical findings, throughout the healthcare institution. Modern systems are strictly based on the international DICOM (Digital Image Communication in Medicine) standard so they can be fully integrated into other information systems in a hospital. Information object class and service class are two basic components of DICOM. The content of a set of images and their relationships are described in the information object class definitions. The operations that can be performed with the information objects are specified in the service class definition [5, 6]. Many PACS installations are only limited to the scope of a particular radiology department or work as a repository of single image generating equipment like ultrasound, CT or x-ray to capture digital images. Effective use of that technology means image distribution at least throughout the whole healthcare institution. However the most promising approach to exploiting the DICOM based PACS technology is to use it at the regional or national level and that way support the associated medical processes. That means not only basic support of daily routines in radiology departments but also the support of distant consultations, digital long-term archiving or development of shared knowledge databases for research and teaching in this particular area.

B. eHealth and Telemedicine

The broader term eHealth generally means the use of information and communication technologies to deliver and administer information and other health related data. The term telemedicine means providing healthcare services from a distance and across other barriers.

There are a lot of different definitions of the term eHealth, some of which are confusing and incorrect. These definitions have been formulated by international organizations such as the World Health Organization, the International Telecommunication Union and by international consortiums and other bodies that try to formulate the policy and create the vision for this emerging interdisciplinary field covering medical informatics, networking and other relevant information and communication technologies in the area of health-related activities [1, 2, 8, 9, 10, 11, 16, 17].

III. ACTIVITIES IN MEDICAL IMAGING

Radiologists need a unified language to help them organize and retrieve particular cases as well as to tag medical images and teaching files with a common terminology. Currently they use a variety of terminologies and continuously evolving medical classifications, but no single lexicon serves all of their needs. The most important in medical imaging are Systematized Nomenclature of Medicine [22], Lexicon for Uniform Indexing and Retrieval of Radiology Information Resources [21], Logical Observation Identifiers Names and Codes [18] and International Classification of Diseases [14]. Medical classification systems are used for a variety of applications in medical informatics. The above mentioned medical classifications also play very important role in our research and are incorporated in our solution.

IHE (Integrating the Healthcare Enterprise) as an initiative of healthcare professionals and industry tries to address specific clinical needs in support of optimal patient care as well as to improve the way computer systems in healthcare share information [15]. Adoption of IHE profiles and coordinated use of established international standards such as DICOM and HL7 [12] is a European trend as well as the best way how to formalize processes and structures in the area of medical imaging. There are some teaching file applications used by radiology educational institutions and leading research institutions all around the world. The MIRC (Medical Imaging Resource Centre) project, overseen by a subcommittee of the RSNA Radiology Informatics Committee, allows users to search multiple imaging libraries of research data through web MIRC portals [19]. Our system is being developed with respect to above mentioned standards and initiatives as well as being inspired by successful regional systems like for instance the HUSpacs in Finland which is one of largest PACS projects in the world. The main idea of our research is the integration platform proposal that represents a new alternative to the integration of existing services and existing DICOM applications in this field. It will enable the medical image processing to be organised different way. Increasing the efficiency of processing can be achieved through greater specialization, more efficient diagnosis associated with access to the latest knowledge and efficient use of expensive equipment capacity and time of medical specialists.

IV. CONCEPTS IN THE AREA OF MEDICAL IMAGE DATA PROCESSING

Most radiology departments using fully digital technology have not yet made a complete transition from the old image data processing to PACS. In the Czech Republic traditional film copies are still widely used by radiologists. However it is difficult and time-consuming to retrieve needed image studies from filled storerooms. The number of examinations accessible via PACS has, however, increased significantly. Radiologists are limited by the number of high quality workstations equipped with PACS feature display technologies. The amount of archive space and bandwidth of hospital computer networks is also a limiting factor. Both the radiologists and the hospital administrators however

appreciate all the advantages of processing the data in digital mode. Fibre optics, phone lines, wireless connections or even satellites can be used to access such digital information now. The coexistence of both technologies, so called film and filmless, is common in healthcare institutions therefore the problems to be solved now are how to move the film based images to PACS and the digital images from PACS, how to annotate them, how to find them, how to identify the patient, the image study, and other such problems. There is a revolutionary concept being referred to as the concept of electronic patient record where every healthcare centre is linked to all the necessary information sources. Medical image studies must be incorporated into that record. All the relevant textual as well as image information throughout many healthcare information systems must be retrievable. The implementation of that concept at a regional level is, especially due to many organizational and legal barriers, a very difficult task. The system emphasizes sharing of expensive medical devices as well as human resources.

V. SYSTEM ARCHITECTURE

A. Supportive Computer Network

Current ICT as well as existing and developing standards enable physicians in the region to deliver some services by the computer network. It means that medical specialists from distant specialised departments can consult urgent cases or make decisions. It is a concept of expert centres based on the practises of telemedicine. Image studies of every patient can be referred to a distant expert centre for a primary diagnostic or second opinion. This way a much higher quality diagnosis can be assured. It is obvious that this concept is not achievable by the functionalities of conventional hospital information systems.

There is a large fibre optic cable network owned and operated by the universities in the city of Brno, the second largest city in the Czech Republic. The development of this network started in 1993. The network connects all the major hospitals spread around the city. The ownership of this network provides the freedom to establish private connections dedicated to advanced applications.

One of the main ideas of the dedicated network is the following: the network firewall, which is connected by a dedicated fibre optic pair to the centre, is in front of a hospital's router/firewall which connects the hospital to the Internet. The administrators of the network are allowed to control access to the central resources, to monitor status of the whole hospital and at the same time allow the administrators of the hospital's network to control access to their network. That way everybody controls access to the part of the network they are responsible for [7].

The schema of the dedicated computer network of the system developed at the Institute of Computer Science of Masaryk University is described at Fig. 1.

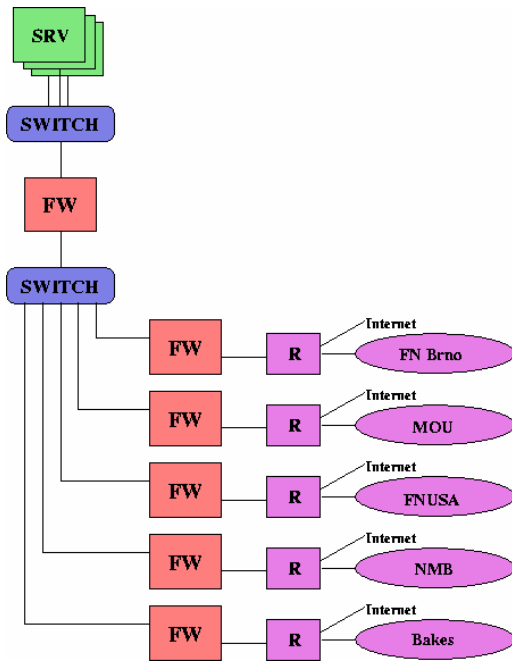

Fig. 1 Interconnection of healthcare institutions to regional PACS servers

Medicine multimedia data processing is based on the DICOM standard. In the case of a single hospital, the problems of user authentication and authorization are easily solved. In the case of a network involving several hospitals, authorization can be based on the IP address of the requesting computer station inside a particular hospital computer network. With greater use of that regional approach the problem of sharing the same resources becomes more complicated. Users of the applications need to change locations several times a day. This can be solved by IPSEC technology and the use of Public Key Infrastructure to achieve IP based authorization to access medical data.

B. Topology

The system is designed as a combination of distributed architecture in terms of incorporated hospital data centres and centralized architecture as the image studies are continuously being sent to the long-term broadly accessible archive in the centre. The image data from the centre can be queried (retrieved) according to predefined rules. The governance of access rights and the administration of the shared resources must be solved in close cooperation with the teams of experts involved. The core components delivering the services of the centre consist of primary installations and secondary installations in the distant locality. The image databases as well as all necessary configurations of the secondary installations are continuously synchronized. In the event of failure of the primary centre the continuous availability of the services must be achieved.

VI. SYSTEM CHARACTERISTICS

A. History

The system has been developing at the Institute of Computer Science of Masaryk University since 1998. The goal was to establish an open, collaborative environment that supports broad cooperation, improves cost-effectiveness, quality of treatment as well as coordinated research and education in the area of processing of medical image data. Healthcare institutions and faculties of medicine can therefore exploit the large potential of databases of medical image information being processed in hospitals today.

The open system, described in this paper, was from the start designed to serve as a reliable and accessible communication node and also as an educational and research tool available to any hospital or other healthcare institution, including medical faculties, that participated in the system.

B. Integration of Medical Imaging Activities

Every particular component of the whole system is certified so it can be integrated into the hospital information system infrastructure of cooperating healthcare institutions. All software tools are strictly based on the DICOM standard and could be easily incorporated into the already running systems. The tailored specialized software for support of communication, research or teaching can also be used for routine diagnostic purposes in radiology departments. The system links together high requirements for original research in this particular area and the efforts to create conditions for as broad an approach as possible to knowledge databases. It enables the level of involvement corresponding with the capabilities of a particular institution. The existence of this collaborative environment makes it easier to qualify for grants, which makes the related work financially more self-sufficient.

C. Quality of Health Care & Economic Efficiency

It is of great importance to investigate the economic efficiency of the above described approach as many healthcare institutions face the challenge of digitalization of medical image processing and other related issues these days. One example is the price comparison between a teleconsultation and a scenario where a doctor has to drive to visit a patient. Regarding productivity and expenses the advantages of the telemedicine activities compared to the traditional methods also seem quite clear. The described system provides an environment for additional, much more sophisticated services supported by advanced applications and delivered by communication infrastructure. The comparative financial study of the above described concept and the possibilities of the common information systems in healthcare enterprises must cover the total price and amortisation of various very expensive shared medical equipments as well as PACS implementation, the total price of medical as well as technical specialists, and other such costs. Determining the economical efficiency of changing traditional health care to telemedical health care is a very interesting but also a very complicated task as the main aim of healthcare institutions is the quality of treatment.

All alternative concepts must be carefully considered and, if possible, divided into components or services that could be provided separately. Validation not only of the technology but also of the organizational and the economical issues is necessary.

D. Related Organizational Issues

Related issues that must be addressed to assess the advantages of the system described above in comparison with the commonly used approach are as follows:

- improvements and effects of digital imaging and communication in a broader context;
- full digitization of all images and sharing of images among the cooperating institutions and their departments;
- cooperation with foreign medical partners;
- cost-benefit analysis of external long-term archiving of image data;
- management of other information associated and processed with image data;
- cost-benefit analysis of the use by radiologists on standby duty at home;
- possibilities of functional integration of radiology departments of more healthcare institutions;
- integration of medical imaging with the concept of an electronic patient record.

E. Knowledge Management and Education in Medical Imaging

Teaching has always been one of the most important parts of radiology. To nurture an excellent radiologist in this age of technology more resources, new methodologies and reorganization of radiological training are necessary.

The core of the system is tailored PACS. PACS can be used as a "PACS trainer" for students and young radiologists. It also forms the basis for additional educational and research applications such as the development of databases of Case Studies describing the treatment of real patients. A Case Study is an integrated hypertext document forming didactic unit and consisting of short texts, structured clinical data, radiological images of various kinds, images from nuclear medicine modalities, macroscopic and microscopic pathology images or video demonstrations recorded during surgeries.

Images appropriate for teaching and research purposes are made anonymous (i.e. the personal data of the patient and other information that may disclose the identity of the patient are replaced with fictitious information or are modified in such a way so as not to lose any relevant information but so as to prevent disclosure of the patient's identity) when sent to an educational and research knowledge database. One of the basic principles when sending images into this database is the coordinated assignment of fictitious patient identity, so it can offer a more complex view of the evolution of the patient's health in situations where the patient is being treated in different healthcare facilities. Therefore, the legal barrier preventing access to sensitive and confidential patient data is removed.

The supporting tools for developing Case Studies can use more common standard technologies thereby providing

additional options for displaying, printing or copying its content. The presentation, including large amount of image data, can be done on-line or off-line, depending on network capacity. The Case Study must be accessible by standard web browser [4]. If the users have a DICOM diagnostic workstation installed on their computers, then the referenced image study can be manipulated and processed by the particular workstation. It means that medical students can access large amounts of systematized medical cases related to their subject. The labs equipped with appropriate software can also serve as training simulators for those studying to be radiologists. The students can learn more from practical lessons instead of spending all their time in the library reading books.

VII. DISCUSSION

A. Support if International Cooperation

One of the major strategic goals of this open system is its internationalization. The supporting computer network infrastructure consisting of dedicated fibre optics or of VPN connections including necessary security equipment enables the medical community all over the world to access the collaborative environment as well as to take advantage of its educational and research applications. Terrestrial and mobile technologies can interact with satellite based platforms to supply effective and reliable end-to-end healthcare services and boost the deployment of telemedicine on a large-scale.

The participation in international programs is, due to the number of experts involved and due to the concentration of financial resources, a unique opportunity to perform research of a very high quality. It also provides an opportunity to be exposed to a multicultural environment and to establish international relationships that are very useful when building the European research area.

To achieve the benefits of international cooperation in this particular area, a wide range of contacts with healthcare enterprises, universities and other involved institutions not only in Europe must be established. The above described approach also aims to bridge the medical digital divide in Europe by designing, integrating and validating interoperable platforms to provide existing and future health care services.

B. Legal Questions

The use of information technologies in telemedicine applications also has many legal aspects. Czech law remains the core of the legal regulation. However other legal systems, the European Union law and international law, are slowly becoming more important. The legal regulations relevant to this concept include, for example, the laws related to personal data protection and electronic signatures. There is a complex legal framework for the general protection of personal data from unauthorized access or other misuse but only fragmentary regulations related to how to exchange such data. Czech law, in the digital age, does not include guidelines for electronic health data exchange between healthcare institutions or other related subjects.

VIII.CONCLUSION

The shared regional collaborative environment is more than just a set of computer network applications. Gradually, it changes the thinking of medical specialists and gets them to cooperate and share data about patients in electronic form. It builds a network of medical specialists. The impact of this work is not only in patient care but also in the education of involved specialists. The implementation of the system has increased the speed of communication among individual hospitals, allowed decision consultations, and brought various other advantages due to dedicated network connections.

There are more than 100 healthcare institutions, mostly from Czech and Slovak Republic, communicating medical images via secure computer network and capabilities of described project. There are 8 big hospitals in the Brno city region which do not operate their own PACS systems and store all their image data in Masaryk University centre. Total storage capacity of fast disk arrays is more than 200TB these days. Continuously evolving shared knowledge database of anonymous image studies serve for education of radiologists and effective decision making in connected hospitals as well as for students from medical faculties in the Czech Republic.

REFERENCES

- [1] American Medical Informatics Association. Available: <<http://www.amia.org>>.
- [2] Association of Telehealth Service Providers. Available: <<http://www.atsp.org>>.
- [3] Bellon, E.; Feron, M. et al. *Incorporating novel image processing methods in a hospital-wide PACS*. In Proceedings of the 19th International Conference of CARS 2005. Berlin: CARS, 2005, pp. 1016–1021.
- [4] Brinkmann, L.; Klein, A.; Glanslandt, T.; Uckert, F. Implementing a data safety and protection concept for a web-based exchange of variable medical image data. In *Proceedings of the 19th International Conference of CARS 2005*. Berlin: CARS, 2005, pp. 191–195.
- [5] Clunie, D., A. *DICOM Structured Reporting*. Bangor, Pennsylvania: PixelMed Publishing, 2000. Available: <<http://www.pixelmed.com/srbook.html>>.
- [6] DICOM Standard. Available: <<http://medical.nema.org/>>.
- [7] Dostal, O., Javornik, M., Slavicek, K. *MeDiMed - Regional Centre for Archiving and Interhospital Exchange of Medicine Multimedia Data*. Scottsdale, USA: International Association of Science and Technology for Development, 2003, pp.609-614.
- [8] European Federation for Medical Informatics. Available: <<http://www.efmi.org>>.
- [9] European Health Telematics Association. Available: <<http://www.ehtel.org>>.
- [10] Health and Science Communication Association. Available: <<http://www.hesca.org>>.
- [11] Healthcare Information and Management System Society. Available: <<http://www.himss.org>>.
- [12] HL7 Standard. Health Level Seven, Inc. Available: <<http://www.hl7.org/>, <http://www.hl7.cz/>>.
- [13] Huang, H., K. *PACS and Imaging Informatics*. USA: John Wiley & Sons, 2004.
- [14] ICD - International Classification of Diseases. Available: <http://apps.who.int/classifications/apps/icd/icd10online/>.
- [15] IHE - Integrating the Healthcare Enterprise. Available: <<http://www.ihe.net/>, <http://www.ihe-europe.net/>>.
- [16] IMIA - International Medical Informatics Association. Available: <<http://www.imia.org>>.
- [17] International Society for Telemedicine. Available: <<http://www.isft.net>>.
- [18] LOINC - Logical Observation Identifiers Names and Codes. LOINC Standard. Available: <<http://loinc.org>>.
- [19] MIRC - Medical Imaging Resource Center. Available: <<http://www.rsna.org/mirc/>>.
- [20] Munch, H.; Engelmann, U. et al. *A secure software architecture for collecting and processing medical image data in centers of excellence*. In Proceedings of the 19th International Conference of CARS 2005. Berlin: CARS, 2005, pp. 938–942.
- [21] RadLex - Lexicon for Uniform Indexing and Retrieval of Radiology Information Resources. Available: <<http://www.rsna.org/radlex>>.
- [22] SNOMED - Systematized Nomenclature of Medicine. SNOMED Standard. Available: <<http://www.ihtsdo.org>>.
- [23] Telemedicine Alliance, *Towards Interoperable eHealth for Europe: Telemedicine Alliance Strategy*. Noordwijk: ESA Publications, 2005.