

# Quadrotor Black-Box System Identification

Ionel Stanculeanu, Theodor Borangiu

**Abstract**—This paper presents a new approach in the identification of the quadrotor dynamic model using a black-box system for identification. Also the paper considers the problems which appear during the identification in the closed-loop and offers a technical solution for overcoming the correlation between the input noise present in the output

**Keywords**—System identification, UAV, Prediction Error Method, Quadrotor

## I. INTRODUCTION

IN the last years, the Unmanned Aerial Vehicles have becomes very attractive for the civil applications such as forest fire detection, traffic surveillance [1], rescue missions, environment monitoring [2], agricultural spraying.

Increased interest for the research in the Unmanned Aerial Vehicles (UAV) has been favoured by the recent achievement in Micro Electromechanical Systems (MEMS), power storage, microcontrollers, communications, electronics miniaturization, automation and control.

The UAV can be grouped in two main categories: fixed wings and rotary wing. One of the most used rotary wings vehicle is the quadrotor. Compared with fixed wings aerial vehicle, the quadrotor has several advantages such as Vertical Take-Off and Landing, hovering capabilities, flying at a lower speed, high maneuverability in restricted area. Beside these advantages, the quadrotor is an unstable and high coupled dynamic system which made it difficult to be controlled.

One of the most important steps in designing of the control system able to stabilize the quadrotor is the system identification. So it is clear that developing a control system for quadrotor without having an accurate dynamic model is almost impossible.

### A. Related works

In this section we will present some of the methods which have been used in the identification of the dynamic system of the quadrotor vehicle.

One of the most used methods in dynamic modelling of quadrotor is based of the Newton-Euler formalism. Basically, the mathematical model is obtained by applying the Newton

law in the fixed and body coordinate frames. The orientation of the vehicle body is expressed using the Euler angles parameterization [3].

Another way to find the quadrotor model is based on the Euler-Lagrange formalism. The basic idea of this method is to calculate the Lagrangian of the system taking in account the generalized coordinates and forces and to write the Euler-Lagrange Equations [4].

Modelling the quadrotor's dynamic using the methods described above has as a result, a set of nonlinear equations which cannot be used directly in synthesis of the linear controllers, so these equations have to be linearised in the operating point. Also, these dynamic models have as variables input the forces and moments which act on the quadrotor, but in reality the control variables are the motor commands.

The work in this paper is focused on the quadrotor system identification using a black box approach applied to MIMO system which has as input variable the motor commands.

The paper is structured as follows:

- Section 2 describes the quadrotor vehicle used as target platform for system identification including details about the sensors, actuators, and controllers used to build the vehicle.
- Section 3 outlines the identification method used to perform the closed loop identification.
- Section 4 presets the experiment results obtained.

## II. QUADROTOR CONFIGURATION

The aircraft vehicle used in our experiment is a quadrotor with the following characteristics:

- vehicle frame is built from reinforced fibreglasses;
- distance between the mass centre and each motor is around 230 mm;
- total weight of the vehicle is 1.2 kg, capable of carrying additional weight up to 300 g.

The quadrotor propulsion power is delivered by four brushless motors, mounted in a cross configuration. Each motor drives a three blades propeller, having the diameter of 254mm.

The power required by the four motors is supplied by two lithium-polymer 3 cells batteries, which guarantee a total flight time of around 15 minutes.

I.C. Stanculeanu is currently Ph.D. student of University "Politehnica", Bucharest, 060042 Romania, Department of Automatic Control and Computers (e-mail: stanculeanu\_ionel@yahoo.com)

Th. Borangiu is with University "Politehnica" Bucharest, 060042, Romania, Dept. of Automatics and Applied Informatics, Head of the "Robotics & AI" Laboratory.

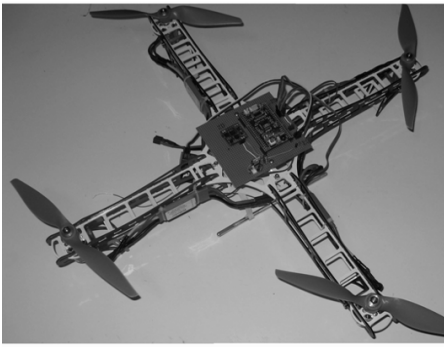

Fig.1 The quadrotor configuration

### A. Hardware Architecture

The objective of this subchapter is to present a short description of the quadrotor control system.

The quadrotor's control system is composed of the following components: onboard computer, sensors and brushless motor controllers.

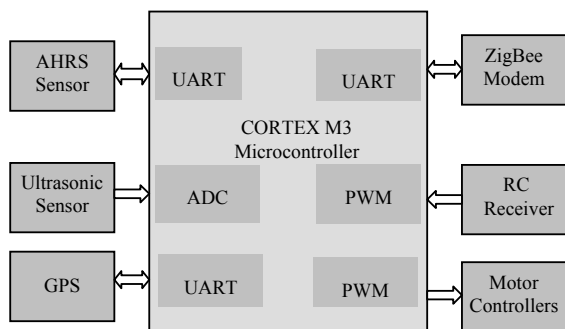

Fig. 2 Autopilot hardware architecture

The onboard computer is custom made component which uses as microcontroller the powerful STM32F103RET6 ARM 32 bit CORTEX M3 microcontroller from STMicroelectronics. The selected microcontroller is running at 72 MHz, offering an outstanding computational performance, flash memory size of 512 Kbytes and 64 Kbytes of SRAM memory.

Besides its computational capabilities, another reason for selecting this microcontroller was its enhanced I/O capabilities: 5 USARTs, SDIO interface, 12-bit A/D converters, 12-channel DMA controller, 6-channel timers with PWM output generation, four 16-bit timers each with up to 4 channels used for pulse width measurement.

The Attitude and Heading Reference is connected to the onboard computer over TTL (3.3V) UART interface at 115200 bits/s, the sample rate is configurable up to 300 angles estimates per second.

The LV-MaxSonar Range Finder has been interfaced with the microcontroller through an A/D converter able to read distance information every 50ms. The resolution provided by the sensor is 10mV / inch).

The following communication devices are connected to the onboard computer:

- a ZigBee modem is connected to the onboard unit over serial interface at 115200 bits/s; this is a full duplex communication device used to send information to the Ground Station and to receive commands from it.

- a RC FUTABA receiver provides five PWM communication channels used to set references (for roll, pitch, yaw and throttle) and to stop the motors in case of emergency situations

To be able to control the quadrotor we need high performing brushless controllers (ESC). For this project we have selected opto-coupled speed controllers from HiModel™. They allow reduction of the electromagnetic interferences generated by brushless motors. The Onboard unit sends commands to ESC using PWM at 50 HZ and the pulse width varies from 1ms to 2 ms.

## III. QUADROTOR SYSTEM IDENTIFICATION

This section presents the method used for identification of the quadrotor dynamics.

### A. Reference frames

First, we shall define the reference frames used to derive the dynamic model. The inertial frame I, denoted by  $(x^I, y^I, z^I)$ , defines a coordinates system, which has its origin in an arbitrary point, x axis points toward North, y axis points toward East direction, and z axis points vertically down. Vectors expressed in the inertial frame have superscript I.

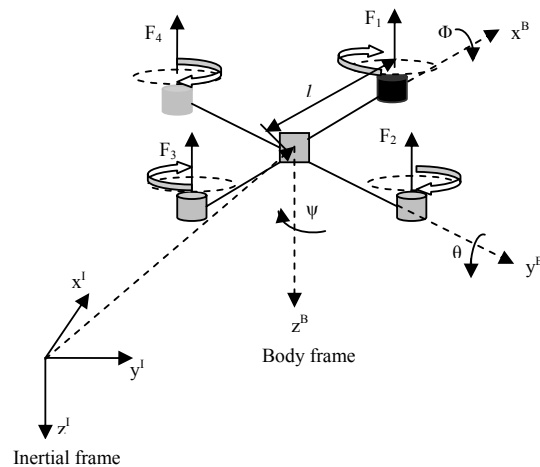

Fig. 3 Definition of the reference frames

Body frame B is fixed onto the vehicle's gravity center; it is denoted by  $(x^B, y^B, z^B)$ . There are several ways to attach the coordinates system to the vehicle's body. In this paper,  $x^B$  points to the nose of the vehicle (longitudinal axis),  $y^B$  points to the right side (lateral axis), and z axis completes the right handed rule.

**B. Statement of the problem**

We shall characterize the dynamic of the quadrotor considering a time-discrete linear model expressed in state-space form:

$$\begin{aligned} x[k+1] &= Ax[k] + Bu[k] + Ke[k] \\ y[k] &= Cx[k] + Du[k] + e[k] \end{aligned} \tag{1}$$

where  $x[k] \in R^n$  is the state of the system at time k,  $u[k] \in R^m$  is the system input,  $y[k] \in R^p$  is the system output and  $e[k] \in R^m$  is a zero mean white noise.

Matrices  $A \in R^{n \times n}$ ,  $B \in R^{n \times m}$ ,  $C \in R^{p \times n}$ ,  $D \in R^{p \times m}$ , and  $K \in R^{n \times m}$  are denoted as the dynamics matrix, control matrix, sensor matrix, direct term and covariance matrix of the disturbance. These matrices are the unknown parameters and they will be the subject of the system identification.

For the particular case of the quadrotor the output vector is denoted by:

$$y[k] = \begin{pmatrix} \phi \\ \theta \\ \psi \end{pmatrix} \tag{2}$$

where  $\phi$ ,  $\theta$ ,  $\psi$  represent the orientation of the quadrotor measured at moment k.

The control input of the quadrotor is defined by the signals applied to motor controllers and it has the following forms:

$$u[k] = (u_1, u_2, u_3, u_4)^T \tag{3}$$

**C. Data acquisition**

One important step in system identification is the data acquisition process. The purpose of this step is to collect a set of data that is informative enough. The ideal case is to use Pseudo Random Binary Signal (PRBS) generator to excite the quadrotor inputs. Unfortunately we cannot apply directly this method because the quadrotor is an unstable system and it cannot be maintained near to hover by using PRBS commands input.

The collection of flight data has been performed in closed-loop, near to hovering point (i.e. translational and angular velocities are zero). The flight stability has been assured by three PID controllers roughly tuned for each axis.

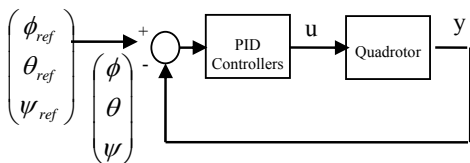

Fig.4 Closed-loop system identifications

Let consider the PID controller designed to stabilize the quadrotor on the pitch axis. Command applied to motor m1 at moment k is given by the following relations:

$$\begin{aligned} e[k] &= (\theta_{ref} - \theta[k]) \\ u_1[k] &= K_p e(k) - K_d \left( \frac{e[k] - e[k-1]}{T} \right) + \frac{T}{T_i} \sum_{i=1}^k e[i] \end{aligned} \tag{4}$$

The PID parameters used for pitch axis have been experimentally adjusted and they have the following value:  $K_p=5.0$ ,  $K_d=1.0$ ,  $T_i=0.5$ .

One problem in closed-loop identification is that input signal is correlated with the noise present in the output. To overcome this problem we have to add a PRBS in the input signals applied to the motor controllers, the resulting commands has the following form:

$$u[k] = u_{PID}[k] + u_{PRBS}[k] \tag{5}$$

where uPRBS signal is a pseudo-random signal of length 31 obtained with the aiding of a shift register with 5 bits.

Using this approach we can have a problem with quadrotor stabilization because the input signals generated by PID controllers have been disturbed with PRBS signal. To overcome this problem we have implemented supervision task which monitor the  $\phi$ ,  $\theta$ ,  $\psi$  angles and deactivates generation of PRBS signals if the quadrotor becomes unstable.

The data acquired is saved on SD card, data can be expressed as follows:

$$\begin{aligned} Y &= [y[1], y[2], \dots, y[N]]^T \\ U &= [u[1], u[2], \dots, u[N]]^T \end{aligned} \tag{6}$$

**D. Identification Method**

There are many identification methods that can be used to determine the dynamic model of a plant from a set of observed data. We could mention here Least Squares, Instrumental Variables and Prediction Error Method (PEM). Some of methods referred above cannot be used in closed-loop system identification because the input of the plant is correlated with the noised output of the plant and the estimated parameters would be biased.

The Prediction Error Method (PEM) make an exception, it can offer good result even the identification is performed with the system in the closed-loop [5]. For this reason we have selected the PEM to be used in our identification experiment.

The basic idea of the Prediction Error Method is to estimate the unknown parameters  $\hat{\theta}$  of dynamic system which minimizes a quadratic criterion applied to the prediction error.

The quadratic criterion can be expressed through the following relation [5] :

$$V_N(\theta, Y, U) = \frac{1}{N} \sum_{k=1}^N \varepsilon(k, \theta)^T \varepsilon(k, \theta) \tag{7}$$

where  $\varepsilon(k, \theta)$  is the prediction error.

**IV. EXPERIMENTAL RESULTS**

The identification of the quadrotor dynamic model have been performed closed-loop, quadrotor being stabilized by PIDs based regulators. The flying weight has been set to a

constant value; it was measured with a precision ultrasonic sensor.

Before applying the prediction error method the acquired data set has been filtered and mean values has been removed from it.

The following matrices are estimation parameters of the (1), these parameters are outcome from PEM algorithm applied to data set with 450 samples:

$$A = \begin{pmatrix} 1.0 & 0.000418 & -0.00158 \\ -0.0084 & 0.94274 & 0.000056 \\ 0.00077 & -0.0063447 & 0.95262 \end{pmatrix}$$

$$B = \begin{pmatrix} -0.0209 & 0.0003 & -0.0188 & 0.0234 \\ -0.1599 & -0.0398 & 0.1465 & 0.0781 \\ -0.0047 & -0.1488 & 0.0532 & 0.2093 \end{pmatrix} * 0.001$$

$$C = \begin{pmatrix} 0.4466 & -0.7958 & -32.6849 \\ 10.5246 & 48.2805 & -1.5825 \\ -136.7715 & 0.3417 & 0.7676 \end{pmatrix}$$

$$D = \begin{pmatrix} 0 & 0 & 0 \\ 0 & 0 & 0 \\ 0 & 0 & 0 \end{pmatrix}$$

$$K = \begin{pmatrix} 0.0011 & -0.0001 & -0.0032 \\ 0.0078 & 0.0137 & 0.0016 \\ -0.0175 & -0.0065 & -0.0010 \end{pmatrix}$$

We provide below graphical representation of the quadrotor measured output together with predicted output using the identified state space model.

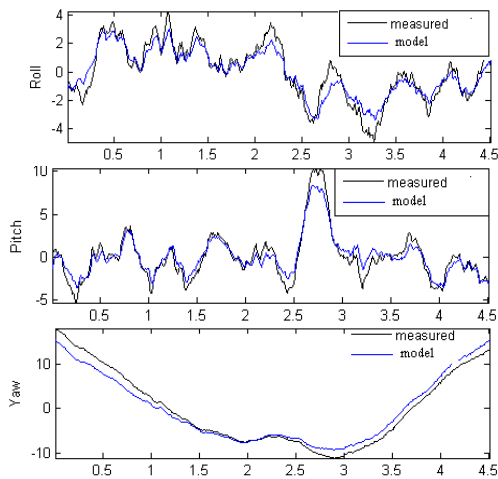

Fig.5. System identification of the quadrotor

## V. CONCLUSIONS

This paper has presented the prediction error method applied to identification of the quadrotor using a state-space discrete model. From the Fig.5 one can observe that identified dynamic model performs quite well. The future

work is to extend the state-space model with new states such as: linear velocities, global position.

## REFERENCES

- [1] Anuj Puri, A Survey of Unmanned Aerial Vehicles (UAV) for Traffic Surveillance, CiteSeerX - Scientific Literature Digital Library and Search Engine (United States)
- [2] M.C.L. Patterson, A. Mulligan, J. Douglas, J. Robinson and L. Wardell. Volcano Surveillance by ACR Silver Fox, AIAA 2005 – 6954
- [3] S. Bouabdallah, R. Siegwart, Full control of a quadrotor, Intelligent Robots and Systems. IROS 2007. IEEE/RSJ International Conference
- [4] P. Castillo, A. Dzul, R. Lozano, Real-time stabilization and tracking of a four-rotor mini rotorcraft, Control Systems Technology, IEEE Transactions, July 2004, pages: 510 – 516
- [5] L. Ljung, System Identification: Theory for the User. 2nd Edition, Prentice Hall PTR 1999