

Prospects for Building Mobile Micro Hydro Power Plants with Information Management Systems

B. S. Akhmetov, P. T. Kharitonov, L. Sh. Balgabayeva, O. V. Kisseleva, T. S. Kartbayev

Abstract—This article analyzes the applicability of known renewable energy technical means as mobile power sources under the field and extreme conditions. The requirements are determined for the parameters of mobile micro HPP. The application prospectively of the mobile micro HPP with intelligent control systems is proved for this purpose. Variants of low-speed electric generators for micro HPP are given. Variants of designs for mobile micro HPP are presented with direct (gearless) transfer of torque from the hydraulic drive to the rotor of the electric generator. Variant of the hydraulic drive for micro HPP is described workable at low water flows. A general structure of the micro HPP intelligent system control is offered that implements the principle of maximum energy efficiency. The legitimacy of construction and application of mobile micro HPP is proved as electrical power sources for life safety of people under the field and extreme conditions.

Keywords—Mobile micro hydro power plants, information management systems, hydraulic drive.

I. INTRODUCTION

THE ever-growing equipment of *Homo sapiens* with electrical and electronic means of modern civilization requires wide availability of independent sources that can provide continuous power for the modern machinery under both conventional and the field conditions. In the absence of the possibility to replace or recharge the built-in battery cells the modern technology is unusable, which significantly reduces the possibility of normal life activities under the field conditions and the people's survival in extreme situations.

II. SOLUTION OF THE PROBLEM

Except of the battery and dry cells and galvanic batteries for powering the various devices under the field and extreme conditions, the photovoltaic dynamo electrical transducers, as well as the micro wind turbines (WT) and micro hydropower plants (HPP) may also be used.

Table I summarizes the main averaged modern characteristics of these primary electrical power sources.

Indicators $P_{out}/V \cdot m$ (ratio of nominal output power to weight and size), W_{pot}/C_K (ratio of the potential energy at the output to a sales price), D_a - long-term endurance in the field and emergency situations, and "Environmental cleanness" are expressed in percentage to the best indicator.

B. S. Akhmetov is with the Kazakh National Technical University, Almaty, 050013 KZ (phone: 8707-547-4248; e-mail: b_akhmetov@rambler.ru).

P. T. Kharitonov, L. Sh. Balgabayeva, O. V. Kisseleva, and T. S. Kartbayev are with the Kazakh National Technical University, Almaty, 050013, KZ.

Analysis of parameters specified in the table allows you to be established in need of development and widespread use of mobile micro HPP to improve the safety of people's life activities under the field and extreme conditions. Other primary electrical power sources have significant limitations in this field, namely:

- Electrical batteries and electrochemical cells are useless after a full discharge in the absence of the possibility to recover their charge;
- Photovoltaic sources are operable at a sufficiently high level of solar radiation and useless at night, as well as dust and other contamination of their surface or the atmosphere;
- Dynamoelectric sources [1] have limited use, mainly on moving objects such as vehicles, as well as in the pavement, etc.;
- Power output from the micro wind turbines per unit area that receives a wind flow, is about 800 times lower comparing with the micro HPP due to the higher density of the water flow comparing with air, besides the wind does not occur sometimes.

The latter circumstance is the result of well-known law of the laminar flow energy impact of a particular environment on the surface orthogonally placed in the flow: $E = \xi \cdot v^3 \cdot S / 2$, where

ξ and v — medium density and the flow rate respectively;

S — surface area of the canvas in the flow.

As the water density $\xi = 1000 \text{ kg/m}^3$, and air density at normal atmospheric pressure and temperature of 20°C $\xi = 1.29 \text{ kg/m}^3$, it is obvious approximately 800 fold difference in the required proposer's receiving surface at the same water or air flow rate.

The only restriction of widespread application of micro HPP is the presence of water flow, moreover it is extremely important to ensure their performance in any environment - from a small stream to the deep river. Accordingly, the mobile micro HPPs shall meet the following requirements:

- 1) rated output power from 25W to 2.5kW (5-9 variants);
- 2) operational ability at water flow rates from 0.5 s and higher at the flow depth of 200mm and higher;
- 3) possibility of transportation in a carrying case or in the car's trunk;
- 4) minimum installation time and complexity in the water flow, as well as dismantling into the transport position;
- 5) specific sales price not exceeding \$300 for every 100W of rated power output of micro HPP.

Analysis of mobile micro HPPs [2]-[4] available on the global market shows that they do not satisfy these requirements in full.

TABLE I
THE BASIC AVERAGE CHARACTERISTICS

Class of primary electric power source	CHARACTERISTICS					
	$P_{out}/V \cdot m$	W_{flow}/C_x	Environmental cleanliness	Additional conditions	Service life	D_a
Electric batteries	100%	100%	~30%	Pre-charging	Up to 1,000 full discharge cycles	~5%
Electric cells	~15%	~5%	~50%	No	Until full discharge	~5%
Photovoltaic sources	~5%	~5%	~80%	Daylight hours	(5-7) years	~15%
Dynamoelectric transducers	~5%	~5%	~80%	Certain mechanical effects	Up to 1,000 hours	~15%
Micro wind turbines	~0,1%	~1%	~70%	Wind	Up to 20 years	~25%
Mobile micro HPP	~15%	~25%	100%	Water flow	Up to 20 years	100%

Micro HPPs made by the Burge Energy Company [2], (see Fig. 1), is able to operate at water flow rates from 2 m/s and water flow depth at least 1.2m. Hydraulic propeller drive enclosed in the bottom of the micro HPP is associated with electric generator installed in the upper body by two conical overdrives. Such an arrangement is the result of the electric generator's application herein having the angular rotation speed of 120rpm and higher. Low-speed electric generators available in the patent and scientific literature having an angular rotation speed of 10rpm and above [5]-[9] are being developed and could not be applied in this arrangement. Horizontal axial propeller type hydraulic drive used in the micro HPP [2] has a high specific speed which allows achieving the increased angular rotation speed. Inevitable consequence of the application of this type of proposer is considerable depth of water flow required to ensure freedom of propeller's rotation in the water flow.

Another disadvantage of these micro HPPs is mandatory mounting on a rope, fastened with guy lines, which significantly complicates its installation and removal. Moreover, the high sales price of these micro HPPs of no less than \$3,000 at rated output power of 500W also significantly restrains the amount of their purchase.

More compact version - micro HPP «VENA» [3], as shown in Fig. 2 is an inflatable body with neutral buoyancy enclosing the electric generator. Outside the housing on the cable connected to the axis of the electric generator, a propeller is mounted in a form of several flexible curved blades. Electrical cable coming from the housing is used for holding the micro HPP in a flow. Rated power of the micro HPP «VENA» does not exceed a few tens of Watts. In order to prevent twisting of the electric cable the anchor for fixing the micro HPP to the ground is included into the package. Widespread use of these micro HPP is restricted by small output electric power and the need to mount the micro HPP's housing to the ground using anchors. The latter requirement complicates its placement into the flow and withdrawal from the flow.

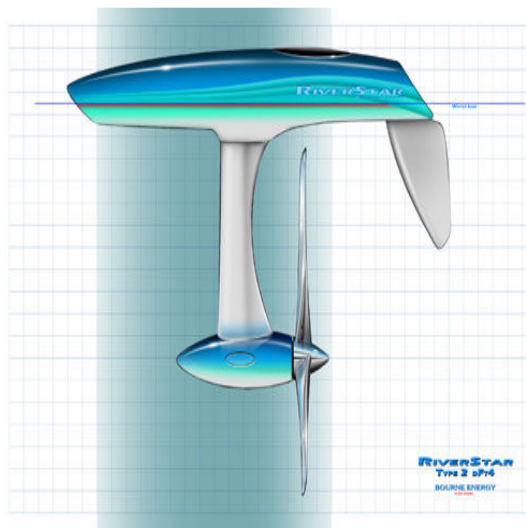

Fig. 1 Design of transportable micro HPP of Burge Energy



Fig. 2 Mobile micro HPP «VENA» in operational and transport conditions

The main advantage of this option of micro HPP is compact transport position and lightweight design with a direct connection of the hydraulic drive to the electrical generator's rotor via a flexible cable.

Original design of the hydraulic drive in the form of elastic curved blades (see Fig. 3) enables to provide the micro HPP with minimum transport overall dimensions. Future options of micro HPP could include inflatable body and easy conducting rope for electric energy collection and structure retention in the flow.

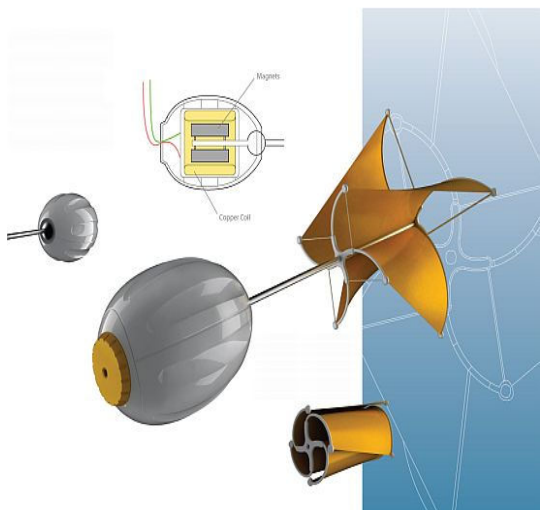

Fig. 3 Design of hydraulic propulsor and electric generator and micro HPP “VENA”

It is known that water flow power **P** providing rotation of the hydraulic drive can be assessed by following formula:

$$P = H \cdot D \cdot g \cdot \eta,$$

where,

H – head (height difference of input and output ends of hoses, in meters);

D – water flow rate (through the hydraulic drive) in liters per second;

G = 9.8 m/c – free fall acceleration;

η – hydraulic drive efficiency.

According to the growth in a head **H** the flow rate **D** increases in quadratic dependence that ensures possibility to provide quite high electric power at relatively low dimensions of derivative micro HPP.



Fig. 4 Appearance of derivative micro HPP with pressure hose

Flexible pressure hose can be rolled up in the transport position. This kind of micro HPP can be attributed to the mobile version due to considerable time of mounting and dismounting on a shore of the water flow as it is necessary to ensure safe storage of the intake end of the pressure hose upstream and installation of the micro HPP housing on a horizontal platform with water draining into the main flow

downstream. Obviously, the derivative micro HPPs are applicable for sufficiently strong, preferably mountain water flows that limits their widespread use under the field and extreme conditions.

For the purpose of successful resolving of the problem to construct the mobile micro HPPs, meeting the set requirements, the authors of this article proposed a number of new technological solutions, including:

- options for low-speed electric generators with compensation of rotor’s magnetic confinement forces [5]-[10];
- Intelligent PTO Control System operated to maximize energy efficiency, proposed in the paper [11];
- hydraulic drive design for micro HPP at water flow rates of 0.5 m/c and above;
- designs of mobile micro HPPs with direct (without multiplier) connection of hydraulic drive axles and electric generator rotor [12]-[14];
- software and hardware complex for management and calculation of energy parameters of the micro HPP under real operating conditions, the concept of which was proposed in the famous paper of authors [15].

Figs. 5 and 6 show the option for low-speed electric generator [5] for mobile micro HPP. Rotor magnetic systems (RMS) with permanent magnets 2 and magnet separators 3 are arranged on the disc rotor 1 (see Fig. 5) with constant angle pitch.

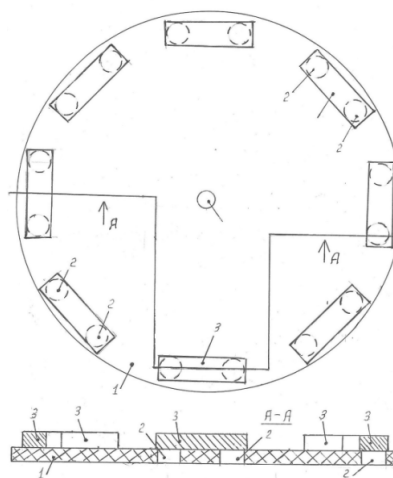

Fig. 5 Electric Generator Disc Rotor Structure [8]

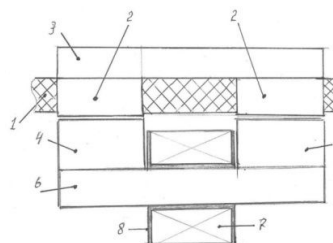

Fig. 6 Mutual arrangement of RMS and SEMS in electric generator

RMS interacts with stator-type electromagnetic systems (SEMS) containing permanent magnets 4 and 5, cores 6 (see Fig. 6)

This design uses one of few pairs of SEMS, and the polarity of the magnetic poles of the RMS and SEMS is selected ensuring compensation of the electric generator rotor's magnetic confinement forces by a known method [7]. Due to use of permanent magnets with high coercive force, a significant change was achieved in the SEMS's magnetic fluxes even at low angular rotation speeds, and tangible values of electric power can be collected from the windings 7 at the angular rotor's speed of 10 rpm and above.

Another option for low-speed electric generator for the micro HPP [10] with bilateral arrangement of SEMS is presented in Fig. 7.

Bilateral arrangement of SEMS 4 relatively to permanently magnetized poles 3 of the rotor 2 improves the energy efficiency of the electric generator. Beveled surfaces of the magnetic poles of the RMS and SEMS (see Fig. 8) also provide a significant increase in energy efficiency due to decomposition of magnetic interaction forces of the poles on the axial and tangential components.

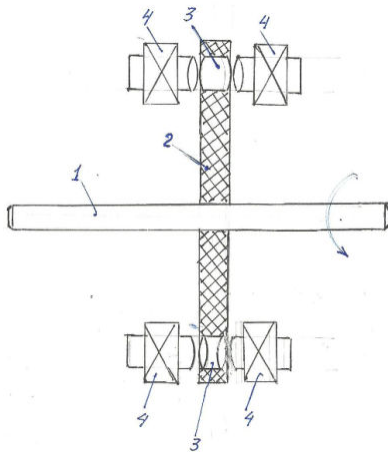

Fig. 7 Option for Electric Generator with Bilateral Arrangement of SEMS

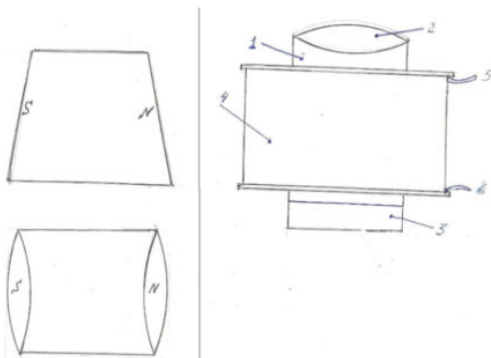

Fig. 8 Option RMS (left) and SEMS (right) with beveled magnetic poles

Core 1 of SEMS has beveled magnetic pole 2 the polarity of which is set by the permanent magnet 3, placed at the bottom of core 1. The angle of inclination of beveled poles of the SEMS and RMS to the plane of the rotor disc may be selected in the range from 1 to 30 arc minutes, degrees and depending on the geometry and other parameters of the permanent magnets in this range of angles of inclination, the values are possible with achievement of the maximum energy effect. Output winding 4 of the SEMS is provided with pins 5 and 6 for electricity collection.

Fig. 9 shows structure of micro HPP [13] based on the low-speed electric generator [10] with bilateral SEMS arrangement. Inclined housing 1 on the axis 2 encloses the hydraulic drive including the cage 3 and blades 4. Water flow enters the inlet conduit 5 and outgoes via the output conduit 6, acting on the blades 4 and providing rotation of axis 2 with the electric generator rotor 9. The level difference Δh of the water flow at the inlet and outlet of the micro HPP ranges (200-500) mm with a rated power output from 500W to 2.5 kW. This design is focused on 100% use of water flow from small streams.

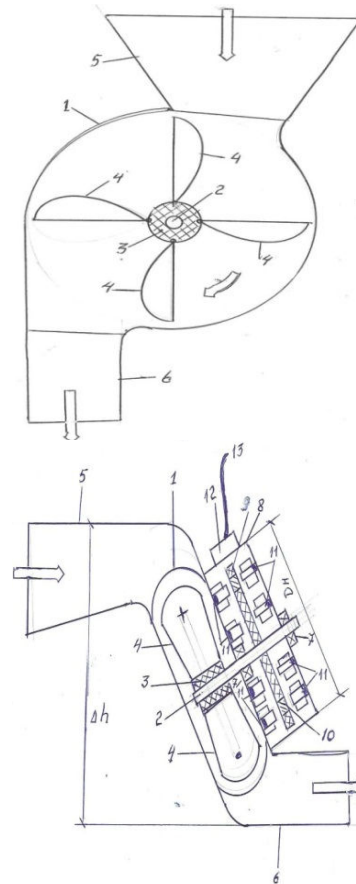

Fig. 9 Option for design of the micro HPP [13] without electric generator (at the left) and section view along the hydraulic drive rotation axis (on the right)

More compact design of the float-type mobile micro HPP is proposed by the authors in the application for innovative patent RK [14] and is presented in Fig. 10.

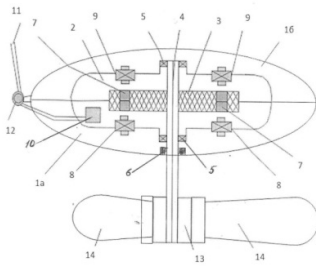

Fig. 10 Design of mobile micro HPP (section view along the rotation axis)

Halves 1a and 1b of the casing made of material with positive buoyancy a cavity 2 is formed in which the rotor disc 3 is arranged mounted on the axis 4 freely rotating on bearings 5 and 6 provided with a pressure seal. Rotor magnetic sectors 7 interact with the lower 8 and the upper 9 SEMS the terminals of which are connected to the adapter 10. Terminal of the adapter 10 is connected with conducting rope 11 fixed to the housing of micro HPP with element 12. The bottom of the axis 4 is connected to hydraulic drive yoke 13 containing rotary blades 14. In order to transit the micro HPP from transport to operating position it is lowered into the water flow and the connecting rope 11 is attached on the shore for a few minutes. Free rotation of the hydraulic drive takes place at the water flow depth from 200 mm and above. Rated output power of this variant of mobile micro HPP may be provided in the range from 25W to 500W, depending on the geometry and magnetic characteristics of the RMS and SEMS. Approximate ratio of rated output power to mass of this micro HPP is (1.6 - 2.4) kg/100W.

The hydraulic drive [14] shown in the Fig. 11 is proposed by the authors in order to provide operability of mobile micro HPPs at the water flow rates from 0.5 m/s and above.

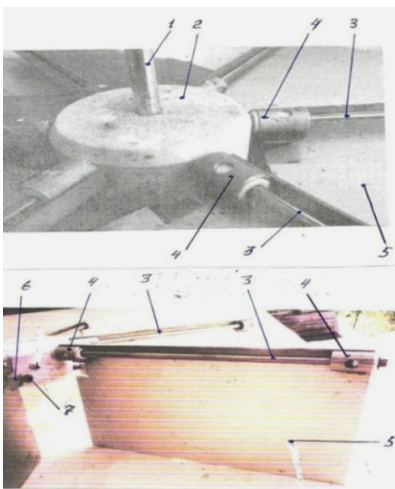

Fig. 11 Design of hydraulic drive with rotary blades

The cage 2 is fixed on axis 1 of the hydraulic drive with two horizontal axes 3 for rotary blades 5 equipped with bushings 4 for free rotation in axes 3. In order to hold the blade in a vertical position the shoulders 6 are provided on the blades and the stoppers 7 are provided on the cage. At the angular displacement of 90° or more the blades under the action of water flow take a horizontal position returning to a vertical position at the subsequent rotation for 180° or more. This design provides increased torque on the axis 1 at low water flow rates.

Maximum energy efficiency of the micro HPP is achievable using intelligent control system applying the new technical solutions published by the authors [11], [15], [16]. Fig. 12 shows the general structure of intelligent control system of the micro HPP, implementing the principle of maximum energy efficiency.

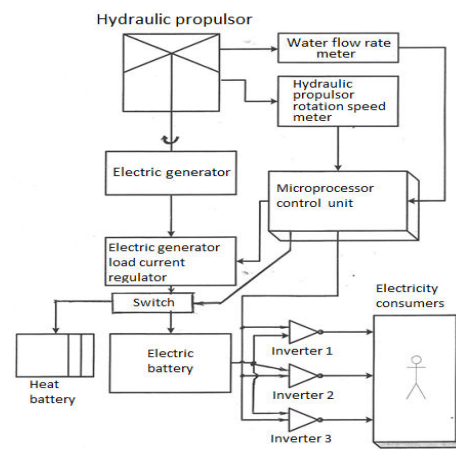

Fig. 12 General structure of intelligent control system of the micro HPP

During its rotation of the hydraulic drive in water flow the electric current is fed from the electric generator terminal through the load controller, controlled via the terminal of microprocessor control unit (MCU) and switch to the electric battery. MCU outputs are connected to the inputs of the water flow rate sensor v_p and hydraulic drive rotation speed sensor v_v . Memory of MCU contains the program to maintain a certain v_p / v_v ratio providing the criterion of maximum water flow energy extraction. When exceeding the v_p / v_v value of set point, the current increasing signal is sent to the electric generator load current regulator and vice versa. The torque is directly dependent from the load current of the electric generator, and hence the angular rotation of its rotor. As a result, the maximum rate for any occurring water flow rate is collected to the electric battery or, when fully charged - into the heat battery.

Switching from electric battery charge to the accumulation of thermal energy and vice versa is performed from the output of the microprocessor upon the results of monitoring of the electric battery status. Along with functions to maintain the certain v_p / v_v ratio and switch control, the microprocessor of the micro HPP calculates the resource (time) of uninterrupted

power supply to consumers with a capacity exceeding electric generator's power with a water flow available, as well as is able to control the inverters' turning on and off times. In addition, it is possible to calculate the energy generated and consumed over a given time interval and perform other information-management functions.

III. CONCLUSION

Sharing in future options of micro HPP of copyright technical solutions for low speed electric generators, hydraulic drive with vertical rotary blades, mobile micro HPPs and intelligent control system creates the perspective to design the micro HPP with parameters indicated in Table II. No any other option of primary electrical power source discussed at the beginning of this article is able to provide a set of parameters listed in Table II. Designing and arrangement of serial production of mobile micro HPPs as electrical power sources under the field and the extreme conditions of people's stay is scheduled by the beginning of 2017.

TABLE II
COMPLEX OF PARAMETERS

Parameter	Value	Remarks
Water flow rate, m/s	from 0.5 and above	
Water flow depth, m	from 0.2 and above	
Time of mounting or dismantling, min	2 – 15	Depending the option of the micro HPP
Possibility to supply a power exceeding the rated value	available	In the presence of an intellectual system and battery
Ratio of mass to rated output power, kg/100W	1.6 – 2.4	
Ratio of sales price to rated output power, \$/kW	Up to 3,000	
Invariance to the time of day and year of consumers connection	Yes	
Service life, years	At least 20	

REFERENCES

- [1] Kharitonov P.T. Inverter of turbulent flow energy into electric charge. Patent RU No.92257 dated 10.03.2010 for the PM.
- [2] Mobile hydro power plant for tourists and the military. Website of Burge Energy (USA).
- [3] Micro HPP "VENA". Website
- [4] Derivative micro HPPs
- [5] Akhmetov B.S., Kharitonov P.T. Methods to improve power efficiency and reliability of permanent magnets electric machines. Material of reports IRTC "Engine building problems", Samara, 2011, Part 1, p.254-255.
- [6] Akhmetov B.S., Kharitonov P.T., Chebotar A.E. Electric machine with disc rotor. Application RU No. 211103512 dated 01.02.2011. Res. FIPS dated 02.08.2013 to grant an invention patent RU.
- [7] Kharitonov P.T. Method and arrangement for mutual compensation of retarding forces in the permanent magnet electric generator. Invention patent RU No. 2394336 dated 10.07.2010.
- [8] Akhmetov B.S., Kharitonov P.T. Electric generator with compensation of the rotor retarding magnetic forces. Invention patent KZ No.26179 dated 14.09.2012.
- [9] Akhmetov B.S., Kharitonov P.T., Nabyeva G.S. Electrical machine with double disc rotor. Invention patent KZ No.27092 dated 22.06.2012.
- [10] Akhmetov B.S., Belyakov B.A., Kharitonov P.T., Nuralikyzy S. Electrical machine with open poles SEMS. Application No.37848 dated 28.12.2011 for an Invention patent KZ.
- [11] Kharitonov P.T. et al. Uninterruptible power supply system for consumers from wind turbines. Patent RU № 104252 dated 10.05.2011 for the PM.
- [12] Akhmetov B.S., Kharitonov P.T. Mobile micro HPP. Invention patent KZ №26179 dated 14.09.2012.
- [13] Akhmetov B.S. Balgabaeva L.Sh., Kisseleva O.V., Kharitonov P.T. Mobile micro HPP. Application №36595 dated 01.11.2013 for an Innovative patent KZ.
- [14] Akhmetov B.S. Balgabaeva L.Sh., Kisseleva O.V., Kharitonov P.T. Mobile Micro HPP Application №4277 dated 21.01.2014 for an Innovative patent KZ.
- [15] Akhmetov B.S., Balgabayeva L.S., Kisseleva O.V., Kharitonov P.T. «Structure and algorithm of operation of microprocessor control unit of the mobile micro HPP» 3. World Conference on Innovation & Sciences, April, 2013, Turkey.
- [16] Akhmetov, B. B., Kharitonov, P. T., Malikova, F. U., Kartbayev, T. S., & Aitimov, M. Z. (2014). Automation of measurement and control for the process of fluid consumption in precision measurement equipment. *Life Science Journal*, 11(6s).