

Power Line Carrier for Power Telemetry

Tosaphol Ratniyomchai, Uthai Jaithong, and Thanatchai Kulworawanichpong

Abstract—This paper presents an application of power line carrier (PLC) for electrical power telemetry. This system has a special capability of transmitting the measured values to a centralized computer via power lines. The PLC modem as a passive high-pass filter is designed for transmitting and receiving information. Its function is to send the information carrier together with transmitted data by superimposing it on the 50 Hz power frequency signal. A microcontroller is employed to function as the main processing of the modem. It is programmed for PLC control and interfacing with other devices. Each power meter, connected via a PLC modem, is assigned with a unique identification number (address) for distinguishing each device from one another.

Keywords—Power telemetry, Power line carrier, High-pass filter, Digital data transmission

I. INTRODUCTION

POWER line communications basically mean any technology that enables data transfer through power lines. Power line carrier communication is mainly used in electric power applications for telecommunication, tele-protection, tele-metering or some other purposes between electric substations. It is normally applied in high-voltage power transmission systems, e.g. 115 kV, 230 kV, 500 kV, etc [1]. The principle of PLC consists in superimposing a high frequency signal at low energy levels over the 50 Hz electrical signal. This second signal is transmitted via the power infrastructure and can be received and decoded remotely. Therefore, the PLC signal is received by any PLC receiver located on the same electrical network. An integrated coupler at the PLC receiver entry points eliminates low frequency components before the signal is treated.

The communication over a power network is rather old. It was introduced in the 1920s by the energy providers, to establish cheap communication between their plants. The basic idea was to use an existing network for communication and not introduce or establish a new one. Later on this concept was adapted to the control of street lightening [2]. So all street lights could be turned on and off by a central “switch” and the lights only needed a small decoder chip. By using this technique no additional wires were needed to control the lights. In the 1980s the technique was introduced on home products, like Baby phones.

The major advantage of using power line carrier as data transmission medium is that every building or house in most

cities is equipped with power lines and connect to a local power grid. The PLC communication uses existing local AC power lines as the data transmission medium to provide data accessibility everywhere there is an AC outlet. This method of data transfer is inexpensive and easier than running new signal wires for this communication purpose. With this technology, broadband over power line carrier [3-4] or remotely power telemetry through PLC [5] in power systems is enabled.

In this paper, exploitation of power line carrier technology is described. The application of online power telemetry is emphasized by transmitting measured data through electrical power circuits between a transmitter and receiver located in the same electrical circuit. A design for a PLC modem is illustrated. In the next section, Section 2, a brief review of online power telemetry is addressed. Section 3 describes a design of power line carrier modems. A coupler circuit of band-pass filters is detailed.

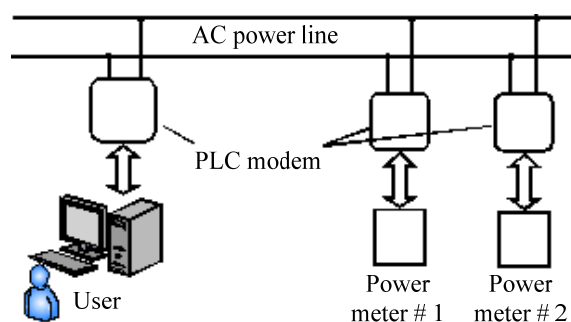

Fig. 1 Online power metering

II. ONLINE POWER METERING

An online metering is an online energy monitoring system to collect meter data via some communication channels and to process this information and then deliver to display devices [5]. It offers a systematic and automated online approach to managing electrical energy consumption, both at supply points to manage actual costs as well as within the industrial plant itself, particularly where costs and efficiencies need to be monitored for large-scale production lines with a great number of manufacturing procedures and steps are involved or divisions within the organization with separate cost centers must be separately accounted for. The online power metering can be summarized as shown in Fig. 1. The power metering system through power line carrier communication as shown in Fig. 1 illustrates the structure and operation of the data transfer system. Each client power meter sends measured data via a serial communication channel to be stored in a memory of a client PLC modem. The server PLC modem has a function to control the data transmission sequence classified

This article is funded by National Research Council of Thailand and Suranaree University of Technology under contract no. SUT7-711-53-12-09

Tosaphol Ratniyomchai, Uthai Jaithong, and Thanatchai Kulworawanichpong were with School of Electrical Engineering, Institute of Engineering, Suranaree University of Technology, Nakhon Ratchasima, THAILAND 30000. (e-mail: thanatchai@gmail.com).

by each modem identification number and therefore stores those data in its memory. A user can access to data stored in the server PLC modem's memory by using the host computer.

III. DESIGN OF A POWER LINE CARRIER MODEM

Power line communication (PLC) leverages the existing power line infrastructure and provides cost-effective approach for introducing intelligent monitoring and control to many industrial applications. It makes PLC one of the leading enabling technologies for Smart Grid applications ranging from smart metering, lighting control, solar, plug-in electrical vehicle home and building automation of heat and air conditioning, and security. For these applications, implementing a low frequency narrow-band PLC technology provides an optimal fit in terms of bandwidth, power, and cost requirements. Operating in the narrowband domain ensures data integrity while minimizing system cost. Developing an efficient PLC implementation is not without its challenges. Power lines are inherently noisy and require a robust architecture to ensure data reliability. In addition, each application and operating environment is different, requiring developers to optimize designs across a variety of factors. With the many protocol standards and modulation schemes available, developers need a flexible development platform which simplifies design, allows for optimization to environmental conditions, supports local regulations, and can be easily adjusted to conform to evolving standards.

Structure of power line carrier communication is shown in Fig. 2. It consists of i) an interfacing part to external devices .e.g. power meter, ii) a modulating part to modulate data with a carrier, and iii) a coupler circuit to allow modulated information through the AC power line.

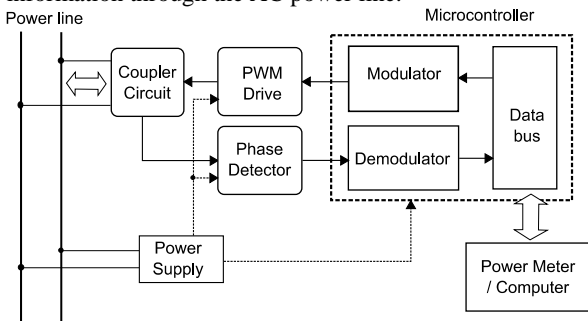

Fig. 2 Simplified diagram of a power line carrier modem

A Power Line Communication Modem system begins with a modulated signal entering the receiver stage, or active band pass filter. It needs to connect to the input of an Analog to Digital Converter fast and accurate enough to properly convert to a digital form for processing. Processed signals are injected back into the power grid by the PLC transmitter stage that drives a high output current. The transmitter stage must be carefully designed to take digital signals from the microcontroller unit, filter them to eliminate out of band emissions and drive the low impedance of the AC power line.

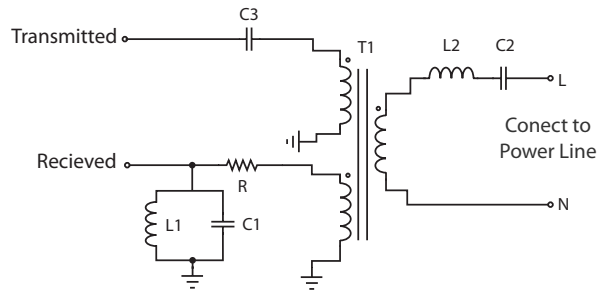

Fig. 3 Coupler circuit of a power line carrier modem

The circuit as shown in Fig. 3 consists of a band-pass filter for transmitting and receiving data between the PLC modem and the AC power line. The band-pass filter is to prevent low frequency components for passing through the PLC side circuit while allowing high-frequency modulated signal transfer between both sides. The design of the band-pass filter requires knowledge of series and parallel resonant circuits [4]. In such circuits, the frequency that causes the sharp peak (resonant peak) is called the resonant frequency (f_0). Briefly, some key characteristics of the proposed resonant circuit are expressed as follows.

$$f_0 = \frac{1}{2\pi\sqrt{LC}} \quad (1)$$

$$BW = \frac{f_0}{R}\sqrt{\frac{L}{C}} \quad (2)$$

$$Q = \frac{f_0}{BW} \quad (3)$$

$$f_0 = \sqrt{f_{c1} \times f_{c2}} \quad (4)$$

$$f_{c1} = \sqrt{\frac{BW^2}{4} + f_0^2} - \left(\frac{BW}{2}\right) \quad (5)$$

$$f_{c2} = f_{c1} - BW \quad (6)$$

Where

Q is the quality factor

BW is the bandwidth

f_{c1} is the lower corner frequency

f_{c2} is the upper corner frequency

By using (1) – (6), as long as some characteristics of the resonant circuit are specified (e.g. resonant frequency, bandwidth, etc), the coupler circuit components (R, L and C) are calculated.

IV. DIGITAL PULSE FREQUENCY MODULATION

Pulse-frequency modulation (PFM) is a modulation in which the pulse repetition rate is varied in accordance with some characteristic of the modulating signal. Pulse-frequency modulation is analogous to frequency modulation of a carrier

wave, in which the instantaneous frequency is a continuous function of the modulating signal. In pulse frequency modulation, the frequency of the pulse train is varied from its default value in accordance with the instantaneous amplitude of the modulating signal at sampling intervals. The amplitude and width of the pulses is kept constant. Fig. 4 gives a description of digital pulse frequency modulation. Also, summary of the DPFM can be depicted as shown in Fig. 5.

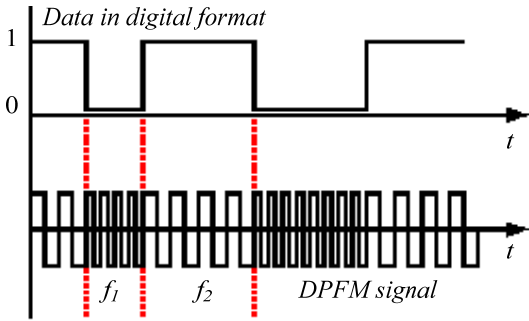

Fig. 4 Digital pulse frequency modulation

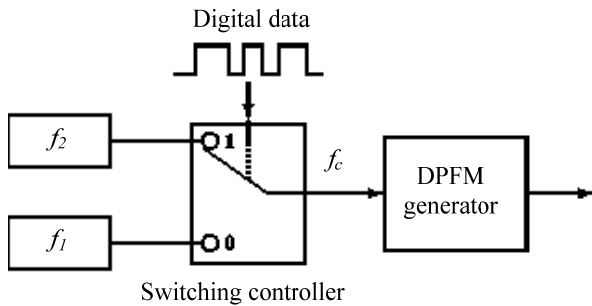

Fig. 5 Procedure of the digital pulse-frequency modulation

Conversely, digital pulse-frequency demodulation is the act of extracting a modulated pulse frequency signal to be converted back to original digital data. The procedure of demodulating the received signal can be shortly summarized as shown in Fig. 6.

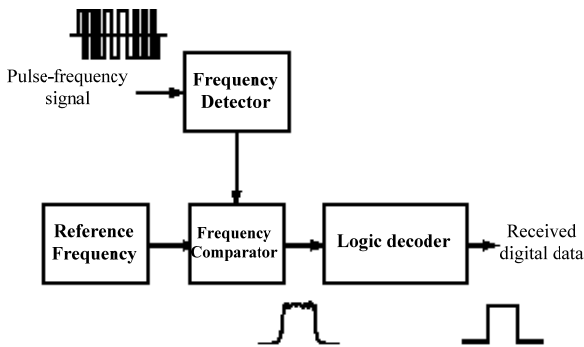

Fig. 6 Procedure of the digital pulse-frequency demodulation

V.PROTOCOL FOR PLC COMMUNICATION

Protocol is a procedure of communication management that is used as a tool to manage the transmission format between the server and its clients attached with power meters as described in Fig. 7. To avoid overlap of data signals, each client modem is assigned with a unique identification number. Communication starts from the server by sending a request to the targeted client in forms of information packet. The data packet contains data type, client ID and CRC (cyclic redundancy check) as shown in Fig. 8. When each client receives the request, the client proceeds checking for matching of the client ID. If the client ID is matched, the client will respond by sending measured data in the specified data type back to the server.

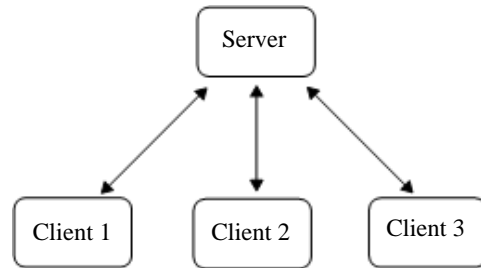

Fig. 7 Procedure of the digital pulse-frequency demodulation

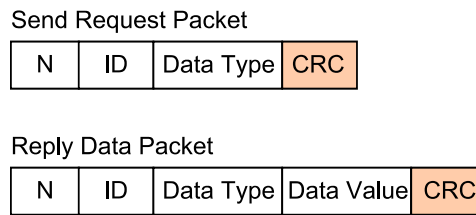

Fig. 8 Data packet

VI. EXPERIMENTS AND RESULTS

In this paper, a power line carrier test system is set for evaluation. The test system consists of a PLC transmitter modem, a PLC receiver modem and power lines. The length of the power line used is 100 m. The test was repeated with a large number of trials, say 10000. The signal to noise ratio and the signal attenuation were evaluated and discussed.

Test of signal quality which is transmitted through power lines is based on evaluation of a ratio between the signal and noises as signal to noise ratio (SNR) and signal attenuation caused by power losses due to power line media. The value of SNR is derived from demodulation of the receiver. This can be achieved by using the calculation as given in the following formula.

$$SNR_{dB} = 20 \log \left(\frac{A_{signal}}{A_{noise}} \right) \text{ dB} \tag{7}$$

Where

A_{signal} is the amplitude of data signal (RMS)

A_{noise} is the amplitude of noises (RMS)

In addition, the signal attenuation (SA) can be calculated by using (8).

$$SA = 10 \log \left(\frac{P_i}{P_o} \right) \text{ dB} \quad (8)$$

Where

P_i is the signal power at the transmitter

P_o is the signal power at the receiver

The test of signal quality was performed by varying the power line length from 0 – 100 m. At each particular length, 10000 trials of signal transfer were carried out. The SA and SNR were therefore calculated as shown in Table I.

TABLE I
TEST OF SIGNAL TO NOISE RATIO

Line length (m)	SA (dB)	SNR (dB)
5	0.44	23.2
20	0.64	22.5
40	1.02	20.6
60	1.16	20.1
80	2.68	19.5
100	3.51	19.2

The results of the signal quality test by assessing the SNR and SA of the signal at some distances as described in Table I revealed that when the line length is increased, the SNR is reduced. The higher the SNR is, the better, as there is less background noise. Longer lines are more sensitive to noise and therefore the quality of the data signal is down.

In addition, data transfer error of the PLC test system is determined. From a data packet, the last portion is CRC which is used for checking the data transfer error. The value of CRC is governed by a polynomial of $x^8 + x^2 + x + 1$. The value of CRC was randomly created and then was included to a data packet to be transferred.

TABLE II
TEST OF CYCLIC REDUNDANCY CHECK

Line length (m)	Number of data transfer error	
	Data comparison	Examining by CRC
5	0	0
20	1	1
40	1	1
60	3	3
80	5	5
100	6	6

From Table II, the data transfer error was increased by the increased line length. This matched with the SNR as reduced by transmission distance. By using the CRC, the data transfer error can be determined.

VII. CONCLUSION

In this paper, a power line carrier communication for power telemetering is presented. The test of signal transmission quality was carried out by a measure of SNR (signal to noise ratio) and SA (signal attenuation) in which the line length of power lines was varied, up to 100 m. The maximum SA and the minimum SNR are 3.51 dB and 19.2 dB, respectively. The test also showed that CRC (cyclic redundancy checking) can be used for evaluation of data transfer error.

REFERENCES

- [1] T. Tran-Anh, P. Auriol and T. Tran-Quoc, "Distribution network modeling for Power Line Communication applications", IEEE Trans. On Power Delivery, pp. 361 – 365, 2005
- [2] G.B. Maizonave, D. Reis and F.S. Lima, "Integrated System for Intelligent Street Lighting", in Proc. Inst. Elect., IEEE Int. Sym. Power-line Comm., vol. 2, pp. 721 – 726, Montreal, Que. 9 -13 July 2006.
- [3] R. Tongia, "Can broadband over powerline carrier (PLC) compete? A techno-economic analysis", Telecommunication Policy, Vol. 28, pp. 559 – 578, 2004
- [4] W. Liu, H. Widmer and P. Raffin "Broadband PLC Access Systems and Field Deployment in European Power Line Networks", IEEE Communications Magazine, pp. 114-118, May. 2003.
- [5] J.V. Wijayakulasooriya, "Remotely Accessible Single Phase Energy Measuring System", in Proc. 1st Int. Conf. and Info Syst, ICIS 2006, pp.304-309, Peradeniya, 8-11 Aug. 2006.
- [6] F. Pacheco, M. Lobashov, M. Pinho and G. Pratl, "A power line communication stack for metering, SCADA and large-scale domestic applications", Int. Symp. Power Line Communications and Its Applications, 6-8 April 2005, pp. 61 – 65