

# Power Generation Scheduling of Thermal Units Considering Gas Pipelines Constraints

Sara Mohtashami and Habib Rajabi Mashhadi

**Abstract**— With the growth of electricity generation from gas energy gas pipeline reliability can substantially impact the electric generation. A physical disruption to pipeline or to a compressor station can interrupt the flow of gas or reduce the pressure and lead to loss of multiple gas-fired electric generators, which could dramatically reduce the supplied power and threaten the power system security. Gas pressure drops during peak loading time on pipeline system, is a common problem in network with no enough transportation capacity which limits gas transportation and causes many problem for thermal domain power systems in supplying their demand. For a feasible generation scheduling planning in networks with no sufficient gas transportation capacity, it is required to consider gas pipeline constraints in solving the optimization problem and evaluate the impacts of gas consumption in power plants on gas pipelines operating condition. This paper studies about operating of gas fired power plants in critical conditions when the demand of gas and electricity peak together. An integrated model of gas and electric model is used to consider the gas pipeline constraints in the economic dispatch problem of gas-fueled thermal generator units.

## I. INTRODUCTION

The growth of power generation in Iran and several other countries is mainly based on constructions of combined-cycle power plants. The increase electricity generation by this technology has tightly linked the electrical system and natural gas system together. As the energy systems move into era of increased interdependency between the gas and electricity sectors, the decentralized approach does not address the interactions between these two sectors with regard to operational, security and reliability issues. It is thus useful to undertake the operational and planning analysis in an integrated manner.

Gas pipeline reliability can substantially impact the electric generation. A physical disruption to pipeline or to a compressor station can interrupt the flow of gas or reduce the pressure and lead to loss of multiple gas-fired electric generators, which could dramatically reduce the supplied power and threaten the power system security. Although in case of certain kind of pipeline contingencies, under ground storage facilities can provide the back up for natural gas supply to some of the units, the power dispatch decisions could be affected by gas pipeline constraints. Gas pressure drop during peak loading time on pipeline system, is another

problem which limits gas transportation capacity and usually happens in systems with inadequate transportation capacity. Although there is enough gas supplies in countries like Iran, lack of enough pipeline capacity causes many problem in supplying the gas demand during peak times.

To perform generation scheduling of thermal units, the maximum amount of power that can be supplied by each unit is required. Without considering the gas pipeline impacts on generation units operating, the maximum power is constant parameter. Nevertheless, maximum amount of power is a nonlinear function of the amount of available fuel for generators.

For a feasible generation scheduling planning in networks with no sufficient gas transportation capacity, it is required to consider gas pipeline constraints in solving the optimization problem and evaluate the impacts of gas consumption in power plants on gas pipelines operating conditions.

Optimal operating of power plants attracts a great deal of attention, as a modest reduction in fuel cost leads to a large saving in system operation cost. One of the important scheduling problems is the economic dispatch problem. The aim of ED problem is allocating of the required load demand between the available generation units, such that the operation cost is minimized while satisfying system constraints. But in some operating conditions for instance during the peak demand of gas pipeline system, the main problem of system operator is to find a feasible solution to supply the electric grid demand by gas-fueled generators. At the time of peak loading in pipeline, the gas transportation system is operating near its stability borders and pressure drop is very likely in the system. So the pipeline system may not be capable to supply the gas-fueled units demand completely. Therefore, to find a feasible solution for generation scheduling, it is necessary to use an integrated model of gas and electric model to consider the gas pipelines constraints.

As the gas-fueled power generators are major natural gas consumers, there is a close interaction between their operation and the pipelines operating condition. The dispatch of gas-fueled power plants affects the gas flow rate and its pressure in pipeline systems. A wise generation dispatch with regards to gas pressure constraints can prevent the pressure drop in pipeline system and meanwhile supply the electricity demand by gas-fueled power plants.

This paper studies about operating of gas fueled power plants in critical conditions when the demand of gas and electricity peak together. An integrated model of pipeline system and gas-fired power plants is used to evaluate the effect of each generator gas usage on the gas flow rate and its

---

S. Mohtashami is with Iran Power Generation, Transmission and Distribution Management Co. (e-mail: srmohtashami@yahoo.com)

H. R. Mashhadi is with the Department of Electrical Engineering, Ferdowsi University of Mashhad, Iran. (e-mail: rajabi\_mashhadi@yahoo.com)

pressure in pipeline system. By using this model we can dispatch the electricity demand between the existing generator units such that no pressure drop happens through the pipelines.

## II. NATURAL GAS MODELING

Natural gas is transported from gas wellheads to different customers by gas transmission network. The NG transportation network model consists of four basic components namely, gas wellheads, pipelines, compressor stations and interconnection nodes. Figure 1 shows a simplified NG transportation network which is utilized in this study for analyzing the impacts of natural gas system operation on the economic dispatch.

The transportation pipelines connect the gas wellhead, usually far from load centers, to distribution system or large industrial users. The compressors act like step-up transformers in electric networks [4]. As gas flows through the pipelines, its pressure will drop. Thus the compressors are an essential component in the natural gas system to maintain the desired pressure level in the transportation pipelines.

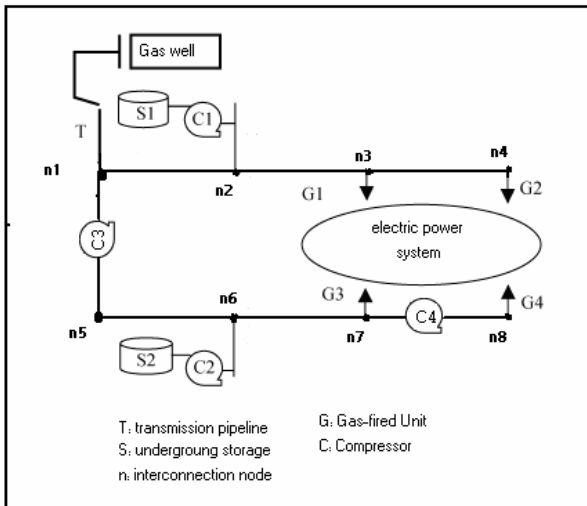

Figure 1: Gas pipeline system [4]

The mathematical formulation of NG system components are presented as follows:

### A. Flow Equation in Pipeline

The flow equations in gas transportation network describe the relation between gas flow rate, the pressures at the two ends of pipelines. For isothermal gas flow in long horizontal pipeline, which begins at node  $i$  and ends at node  $j$ , the general steady state flow rate (in mmscf<sup>2</sup>/hr) is often expressed by the following formula [1]:

$$f_{ij} = S_{ij} \times 0.08531 \frac{T_0}{\pi_0} \sqrt{S_{ij} \frac{(\pi_i^2 - \pi_j^2) D^5}{FGLT_a Z_a}} \quad (1)$$

where:

$f_{ij}$  = pipeline flow rate, mmscf/hr

$S_{ij} = +1$  if  $\pi_i - \pi_j > 0$

$= -1$  if  $\pi_i - \pi_j < 0$

$F$  = pipeline friction factor

$D$  = internal diameter of pipeline (inches)

$G$  = gas specific gravity

$L$  = pipeline length between nodes (miles)

$\pi_i$  = pressure at node  $i$ , psia

$\pi_j$  = pressure at node  $j$ , psia

$\pi_0$  = standard pressure, psia

$T_0$  = standard temperature, <sup>0</sup>R

$T_a$  = average gas temperature, <sup>0</sup>R

$Z_a$  = average gas compressibility factor

Equation 1 is a nonlinear equation that defines the relation between the flow rate through a pipeline and its terminal nodes pressures.

### B. Compressor Model

Gas flow loses a part of its energy during transportation along the pipelines due to its frictional resistance which results in a loss of pressure. To maintain the gas pressure at a desirable level, compressor stations are installed in the network. The amount of energy consumed by compressor stations, can be computed based on "the horsepower equation" as follows: [1]

$$H = B.f[(\pi_i / \pi_j)^{Z(\alpha-1)/\alpha} - 1] \quad (2)$$

Where:

$H$ : compressor rate of work (horsepower)

$B = 0.08531T / \eta^* (\alpha / \alpha - 1)$

$f$ : flow rate through compressor, mmSCF/hr

$\pi_i$ : compressor suction pressure, psia

$\pi_j$ : compressor discharge pressure, psia

$Z$ : gas compressibility factor at compressor inlet,

$T$ : compressor suction temperature, <sup>R</sup>

$\alpha$ : specific heat ratio ( $c_p = c_v$ )

$\eta^*$ : compressor efficiency

The above equation shows the rate of work of each compressor as a function of the gas flow rate through the compressor and the pressure ratio between the inlet and outlet gas.

The compressor stations can use steam, electricity and natural gas as the energy source. Usually, in large pipeline systems, the most economic source is the natural gas, which is available and flowing through the compressors. The amount of gas withdrawn to power a gas turbine to operate the compressor can be approximated as:

<sup>2</sup> -million standard cubic feet

$$\tau = \alpha + \beta.H + \gamma.H^2 \quad (3)$$

Where  $\tau$  is the amount of gas used by compressor, H is horsepower required for gas compressor in equation (2) and  $\alpha, \beta, \gamma$  are the compressor coefficients.

### C. Gas-fired Power Plants Modeling

Gas and electric networks interconnect at gas-fired power generation station. The input-output characteristic of the power plants expresses the relation between the two networks. It determines the gas consumption flow rate in the power plant ( $q_i$ , mmscf/hr) as a function of the generated electric power. This is obtained by dividing the plant's heat energy function ( $H_i$ , MBtu/hr) by the gas gross heating value (GHV, MBtu/mmscf).

$$q_i = H_i \cdot \frac{1}{GHV} \quad (4)$$

Also, we have:

$$F_i = C.H_i \quad (5)$$

where:

$F_i$ : the cost function of the  $i^{th}$  plant

$H_i$ : the heat energy function of the  $i^{th}$  plant

C: the gas energy cost(\$/MBtu)

Replacing  $H_i$  in equation 4 with  $\frac{F_i}{C}$  we have:

$$q_i = F_i \cdot \frac{1}{GHV} \cdot \frac{1}{C} \quad (6)$$

Equation 6 expresses the gas consumption flow rate of the  $i^{th}$  power plant as a linear function of the plant cost function.

### D. Gas load flow problem

The problem of simulation of gas network with N nodes in steady state, known as loadflow, is usually that of computing the values of node pressure and flow rates in individual pipes for known values of source pressures and gas injection in all other nodes. For more studies you can see loadflow statement and solution in [2].

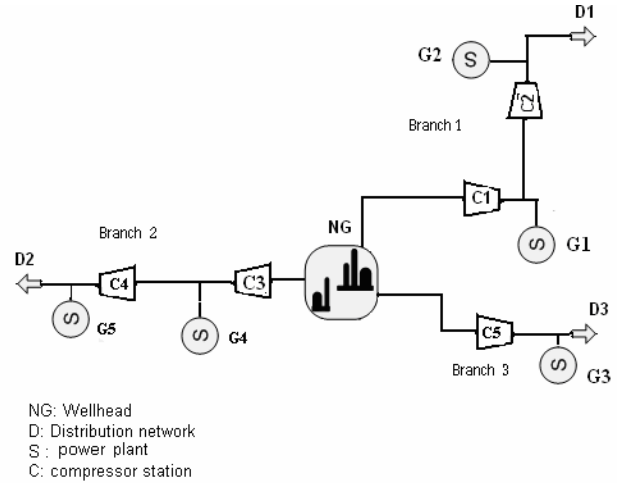

Figure 2: Natural gas network and power plants schematic

### III. ECONOMIC DISPATCH OF DUAL-FUEL THERMAL UNITS CONSIDERING PIPELINES CONSTRAINTS

Figure 2 shows a typical pipeline system that transports gas from wellhead to five electric power plants and other gas consumers. The gas pipeline system is composed of one gas source node and three branches. Branch 1 supplies two power plants (#1, #2) and none electrical industrial users which are presented as D1. The second branch transports gas to power plant #4 and #5 and a gas distribution network, D2. On the third branch, there are power plant #3 and other non-electrical consumers that are represented as D3. Each power plant has multiple gas-fueled generator units. The technical parameters of power plants and their generators are listed in table 1. The gas pipeline system has five compressor stations, two at branch 1, two at branch 2 and one at branch 3. The technical parameters of compressors refers to equation 2 and 3 are in table 2.

Let's consider the gas and electricity demand of a cold winter day. First we use the typical economic dispatch method to determine the power plants generation power. In this case the ED problem is formulated as:

$$\text{Min } \sum_{i=1}^{17} F_i(p_i) \quad (7)$$

Subject to:

$$\sum_{i=1}^{17} p_i = P_D \quad (8)$$

$$p_{i \min} \leq p_i \leq p_{i \max} \quad i = 1, 2, \dots, 17 \quad (9)$$

Table 3 shows the results of the above optimization problem.

Table1: Generators characteristics parameters

No	Number of units	$P_i^{\min}$ (MW)	$P_i^{\max}$ (MW)	$a_i$ (\$/hr)	$b_i$ (\$/MW.hr)	$c_i$ (\$/MW <sup>2</sup> .hr)
1	4	50	175	213.1	15.7	0.008
2	2	30	250	230	11.85	0.008
3	4	50	250	369	14.9	0.009
4	4	15	200	203	11.9	0.008
5	3	37.5	300	280	12.3	0.009
Sum	17 units , 3900 MW					

Table 2- compressors and gas turbine data

No	Efficiency	$\pi_i / \pi_j$	Turbine Fuel Rate Coefficients		
			$\alpha$	$\beta$	$\gamma$
1	0.84	1.4	0	0.2 e-3	0.02 e-3
2	0.83	1.3	0	0.2e-3	0.025e-3
3	0.84	1.5	0	0.2e-3	0.03e-3
4	0.83	1.4	0	0.2e-3	0.03e-3
5	0.83	1.5	0	0.2e-3	0.03e-3

Table 3- The economic dispatch result

Plant No.	Units no.	MW
1	1,2,3,4	175
2	5,6	250
3	7,8,9,10	153
4	11,12,13,14	200
5	15,16,17	170
Total demand	3000	
Total cost	75782	

Now let's see the pipelines operating conditions in the achieved result. First we should calculate the gas consumption of each power plant using the equations 4-6 .When the gas demands of power plants are obtained, the gas flow algorithm is applied to the pipeline system. The simulation result of gas pipelines is shown in table 4. The gas pipelines model used in gas simulation is presented in appendix.

Table 4: gas simulation results for ED result in table 3

Node No.	Pressure	Node No.	Pressure
1	1000	<b>10</b>	<b>-3 i</b>
2	842	<b>11</b>	<b>-20 i</b>
3	1180	12	671
4	966	13	1007
5	928	14	663
6	1206	15	528
7	1175	16	739
8	1169	17	630
<b>9</b>	<b>-2 i</b>		

The simulation result shows that the gas pressure at nodes 9, 10, 11 in branch 3 are not real quantity. This imaginary numbers state that the ED result is not a feasible answer due to the gas pipeline system. The pipeline system does not have the adequate capacity to supply the gas demands in branch 3. As the priority at natural gas network is to serve non-electrical gas consumption, the generation of plant 3 should be reduced due to lack of gas supply and instead the generation of plant 5 should be increased (plants 1, 2 and 4 are generating their maximum capacity). If the increase of generation at plant 5 also leads to gas pressure drop in branch 2, then it would be not possible to supply the electricity demand all by gas energy.

Most of thermal plants have oil storage facilities to use in case of disruption of gas supply. Now the economic dispatch of thermal units with dual-fuel capacity is formulated regards to pipelines constraints.

For the system in figure 2 if all the generator units are equipped with oil storage facilities the economic dispatch problem is formulated as:

$$\text{Min} \sum_{i=1}^{17} [\omega_i C_i(P_i) + (1 - \omega_i) C'_i(P_i)] + \sum_{j=1}^5 c.\tau_j \quad (10)$$

Subject to:

$$\begin{aligned} \sum_{i=1}^{17} P_i - (P_D + P_{loss}) &= 0 \\ P_{i\min} \leq P_i \leq P_{i\max} & \quad i = 1 \dots 17 \\ \pi_{j\min} = 500 \leq \pi_j & \quad j = 1 \dots 17 \end{aligned} \quad (11)$$

$$\omega_i = 0,1$$

$C$  : gas price \$/mmscf

$C_i(P_i)$  = power generation cost in  $i^{th}$  plant when it uses gas

$$= \rho_G * H_i(P_i)$$

$C'_i(P_i)$  = power generation cost in  $i^{th}$  plant when it uses oil

$$= \rho_L * H_i(P_i)$$

$H_i(P_i)$  = Heat energy characteristic of unit  $i$ , Mbtu/h

$\rho_G$  : gas energy cost \$/Mbtu

$\rho_L$  : oil energy cost \$/Mbtu

The optimization variables are 17 output power of generator units and 17 decision variables:  $w_j$ . When  $w_i=1$ , the  $i^{th}$  unit consumes gas as primary energy and when  $w_i=0$  it consumes oil.

Due to various non-linear equations and constraints in simulating the gas pipelines network and also because of the integer variables ( $w_i$ ), genetic algorithm is applied to the optimization problem.

Genetic algorithm (GAs) is an evolutionary optimization approach which is alternative to traditional optimization

methods. GAs are most appreciate for complex non-linear models where location of the global is difficult task. Unlike traditional optimization methods, GAs is better at handling integer variable than continuous variables.

To solve the optimization problem with GA, a chromosome is a bit string composes of 17  $P_i$  variables and 17  $w_i$  variables. The fitness function is defined as:

*Fitness function* =

$$\sum_{i=1}^{17} (\omega_i C_i(P_i) + (1 - \omega_i) C'_i(P_i)) + \sum_{k=1}^5 \cos t(\tau_j) + \beta \left[ P_D + P_{loss} - \sum_{i=1}^{17} P_i \right]^2 + \sum_{j=1}^{17} \alpha_j (\pi_{j \min} - \pi_j)^2 \quad (12)$$

Where  $\alpha_j$  and  $\beta$  are penalty factors and defined as:

$$\beta = 10^5$$

$$\alpha_j = \begin{cases} 0 & \text{if } \pi_{j \min} \leq \pi_j \\ 100 & \text{otherwise} \end{cases} \quad (13)$$

In the previous formulation the ED solution was not acceptable regards to pipelines constraints. Now with this new formulation the best economical power dispatch is obtained with respect to both gas and electricity networks. The gas and oil prices are defined as their prices in Iran. (Gas price = 700 Rials/m<sup>3</sup>, oil price= 6000 Rials/lit). Table 5 shows the optimum generation schedule.

Table 5- The economic dispatch result

Power Plant No.	Gen. No.	MW	Natural Gas / Residual Fuel Oil
1	G 1	175	NG
	G 2	175	NG
	G 3	175	NG
	G 4	175	NG
2	G 5	250	NG
	G 6	250	NG
3	G 7	174	NG
	G 8	174	NG
	G 9	196	residual fuel oil
	G 10	174	NG
4	G 11	200	NG
	G 12	200	NG
	G 13	200	NG
	G 14	200	NG
5	G 15	260	NG
	G 16	71	residual fuel oil
	G 17	260	NG

Table 6 compares the gas pressure in these two operating points.

Table 6: gas pressure in two ED results

Node pressure	Considering pipelines constraint	without Considering pipelines constraint
9	518	-2i
10	777	-3i
11	504	-20i
15	504	528
17	579	630

At the optimum condition of the previous part the gas pressure in nodes 9, 10 and 11 were imaginary and the pressure in node 15 in branch 2 was very close to its lower limit. In new generation scheduling one of the generator units of power plant 3 is switched on oil fuel and thus the pressure drop through branch 3 is removed. The total generation of plant 5 is increased than the previous solution. Therefore, to avoid the gas pressure drop through branch 2, one of its generator units is switched on oil fuel.

As table 6 shows the pressure constraint is active in branch 2 and 3. It indicates that the main goal in solving the optimization problem was to find a feasible solution to supply the electric demand by gas energy as much as possible. This is because the gas energy in Iran is much cheaper than oil energy.

#### IV. CONCLUSIONS

The continual and rapid growth of NG-fueled electricity generating plants has increased the interdependency of natural gas and electricity industries. As the electric power plants are major NG consumers, there is a close interaction between the gas-fired power plants operation and the gas supply system operation. The dispatch of the NG fueled power plants affects the gas flow in the pipeline system and, on the other hand; the pipeline operating constraints can impose limits on power plants generation.

For a secure operation of gas and electricity system, it is necessary to impose some extra constraints on electricity system operation in case of some particular operating conditions. For instance in severe weather situations (e.g., hot summer and cold winter days) when demands for gas and electricity peak together, the pressure drop in pipelines is very likely. In these cases, it is unavoidable to limit the amount of gas used by some power plants to prevent the loss of multiple gas consumers.

This paper studied about operating of gas fired power plants in critical conditions when the demand of gas and electricity peak together. An integrated model of pipeline system and gas-fueled power plants was used to evaluate the effect of each generator gas usage on the gas flow rate and its pressure in pipeline system. By using this model the economic dispatch of thermal units was formulated considering the pipelines constraints. By solving this new economic dispatch problem, the power demand is dispatched between the thermal units in such a way that prevents pressure drops in pipeline system and loss of multiple gas consumers.

V. APPENDIX

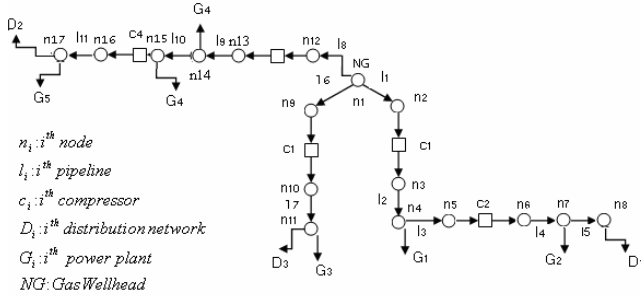

Figure appendix 1. gas pipeline model for solving gas loadflow

B matrices of the loss formula

$$B = \begin{bmatrix} 0.0676 & 0.00953 & -0.00507 & 0 & 0 \\ 0.00953 & 0.0521 & 0.00901 & 0 & 0 \\ -0.00507 & 0.00901 & 0.0294 & 0 & 0 \\ 0 & 0 & 0 & 0.003 & 0 \\ 0 & 0 & 0 & 0 & 0.009 \end{bmatrix}$$

$$B_0 = [-0.0766 \quad -0.00342 \quad 0.0189 \quad 0 \quad 0]$$

$$B_{00} = 0.0403057$$

$$P_{loss} = P^T B P + P^T B_0 + B_{00}$$

VI. REFERENCES

[1] Qing Li, Seugwon An and Thomas W. Gedra, "Natural Gas and Electricity Optimal Power Flow," Proceedings of the IEEE/PES Transmission and Distribution Conference, and presented at the conference in Dallas TX, September 8, 2003. Paper number 03TD027.

[2] Qing Li, Seugwon An and Thomas W. Gedra, "Solving Natural Gas Load problem Using Electric Loadflow Techniques," *Proceedings of the North American Power Symposium, at University of Missouri-Rolla, October 20-21, 2003.*

[3] Oderson Dias de Mello, Takaaki Ohishi, "An Integrated Dispatch Model of Gas Supply and Thermolectric Systems," *presented at 15<sup>th</sup> Power Systems Computation Conference, August 22-26, 2005, Liege, Belgium.*

[4] M. Shahidehpour, Y.Fu and T. Wiedman, "Impact of Natural Gas Infrastructure on Electric Power Systems," *Proceedings of the IEEE, vol. 93, No.5, May 2005.*

[5] Hanjie Chen, Ross Baldick, "Optimization Short-Term Natural Gas Supply Portfolio For Utility Companies," *IEEE Transaction on Power Systems, vol.22, No.1, February 2007*

[6] M.S.Morais, J.W. Marangon Lima, "Natural Gas Network Pricing and Its Influence on Electricity and Gas Markets," In: *IEEE Bologna PowerTech Conference, 23-26 Jun 2003, Bologna, Italy*

[7] A. Wood, B. Wollenberg, "Power Generation, Operation & Control," Wiley-Interscience, 1996, ISBN 0-47158-699-4.

[8] Daniel D. wolf, "Mathematical Properties of formulations of the Gas Transmission Problem," GREMARS, University of Lille 3, France, April 2003.

[9] Samer Takriti, Chonawee Supatgiat, Lilian Wu. "Coordinating Fuel Inventory and Electric Power Generation Under Uncertainty," *IEEE Transactions on Power Systems, Vol. 16, No. 4, November 2001*

[10] Roger Z. Rios Mercado, Suming Wu, L.R. Scott, E.A. Boyd, "A Reduction Technique for Natural Gas Transmission Network Optimization Problems," *Annals of operation Research 117,217-234, 2002.*

[11] C.C. von Weizacker, J. Perner, "An integrated simulation model for European electricity and natural gas supply," *Electrical Engineering 83 (2001) 265-270, Springer-Verlag 2001.*

[12] Chi-Keung Woo, A. Olson, Ira Horowitz, S.Luk, "Bi-directional causality in California's electricity and natural-gas markets," *Energy Policy 34 (2006), pp.2060-2070*

[13] Won-Woo Lee, "US lessons for energy industry restructuring: based on natural gas and California electricity incidences," *Energy Policy 23 (2004), pp.237-259*

[14] "Challenges, Risks, and Opportunities for Natural Gas from Electric Power Industry Restructuring," *Energy Information Administration/ The challenges of Electric Power Industry Restructuring for Fuel Supplies.*