

PIIN Suppression Using Random Diagonal Code for Spectral Amplitude Coding Optical CDMA System

Hilal Adnan Fadhil, Syed Alwei, and R. Badlishah Ahmad

Abstract—A new code for spectral-amplitude coding optical code-division multiple-access system is proposed called Random diagonal (RD) code. This code is constructed using code segment and data segment. One of the important properties of this code is that the cross correlation at data segment is always zero, which means that Phase Intensity Induced Noise (PIIN) is reduced. For the performance analysis, the effects of phase-induced intensity noise, shot noise, and thermal noise are considered simultaneously. Bit-error rate (BER) performance is compared with Hadamard and Modified Frequency Hopping (MFH) codes. It is shown that the system using this new code matrices not only suppress PIIN, but also allows larger number of active users compare with other codes. Simulation results shown that using point to point transmission with three encoded channels, RD code has better BER performance than other codes, also its found that at 0 dbm PIIN noise are 10^{-10} and 10^{-11} for RD and MFH respectively.

Keywords—OCDMA, MFH, PIIN, and BER.

I. INTRODUCTION

FIBER optic code division multiple access (CDMA) techniques provide flexible solution for asynchronous high-capacity communication in the field of digital local area networks. The early incoherent optical CDMA (OCDMA) systems used pseudo-orthogonal sequences to encode signals in the time domain, but the codes were long and multiple access interference (MAI) limited the number of simultaneous users. Thus, spectral-amplitude-coding (SAC) of OCDMA systems was proposed because of its ability to eliminate the influence of MAI and to preserve the quasi-orthogonality between network users [1, 2]. MAI exists in the OCDMA systems when multiple users accessing the same medium using the same time and frequencies for transmitting concurrent data streams. In SAC-OCDMA systems, each user is assigned with a sequence code that serves as its address. An OCDMA user modulates its code (address) with each data bit and asynchronously initiates transmission. Thus, this modifies its spectrum appearance, in a way recognizable only by the intended receiver. Otherwise only noise like bursts is observed [3]. Many code have been used for OCDMA such as Modified Frequency Hopping (MFH), prime codes [2], [4] and Hadamard codes [2], [5], etc. However, since their in-phase cross-correlations were relatively high, as compared with code weight, the phase-induced intensity noise (PIIN) degraded system performance severely. PIIN originated from the

intensity noise caused by the phase noise of the incoherent light fields that were mixed and incident upon a photodiode [5]. The new proposed code is used to improve the signal-to-PIIN noise ratio, this study introduce a code with zero cross correlation at data segment, the systems that adopted this code had improved BER performance and the encoding/decoding devices could be implemented via fiber-Bragg grating (FBG) easily. However, as the lengths of code words used in the frequency domain became larger, the physical length of the FBG array became impractical, and introduced unequal insertion loss for different wavelength chips. In terms of code length a good set of code is to obtain the maximum number of codes with maximum weight and minimum length with the best possible autocorrelation and cross-correlation properties. A code with a larger size should give better BER performance. Hence, unipolar $\{0,1\}$ codes which have low out-of-phase autocorrelation and cross-correlation values are used. Short code length limit the addressing flexibility of the codes, while long code length are considered disadvantage in implementation, since either very wide –bandwidth source or very narrow filter bandwidth are required, RD codes exists for practical code length that are neither too short nor too long. This paper is organized as follows: in Section II we will discuss how the code is developed theoretically and also its properties; simulation results for different OCDMA codes are given in section III, and the conclusion is presented in section VI.

II. RANDOM DIAGONAL CODE PROPERTIES

Many OCDMA strategies have been proposed [4,5], where one of the major concerns of designing RD code sequences is MAI because the performance of such system is usually interference limited. However, due to the characteristics of optical signals, in the direct detection of OCDMA system the signature sequence consists of unipolar (0,1) sequences. We denote a code by N, W, λ where N is the code length, W is the code weight, and λ is in-phase cross correlation. Let us define $\lambda = \sum_{i=1}^N x_i y_i$ as the inphase cross correlation of two different sequences $X=(x_1, x_2, \dots, x_N)$ and $Y=(y_1, y_2, \dots, y_N)$. When $\lambda=1$, it is considered that the code possesses ideal inphase cross correlation. The design of this new code can be preformed by dividing the code sequence into two groups, which are code segment and data segment.

Step1, data segment: let the elements in this group contain only one “1” to keep cross correlation zero at data level ($\lambda = 0$). This property is represented by the matrix ($K \times K$) where K will represent number of users. These matrices have

Authors are with School of Computer and Communication, University Malaysia Perlis, 02000 Kuala Perlis, Perlis, Malaysia (e-mail: eng_hilal_adnan@yahoo.com).

binary coefficient and a basic Zero cross code (weight=1) is defined as $[Y_1]$. For example, for three users ($K=3$), Y_1 can be expressed as

$$[Y_1] = \begin{bmatrix} 0 & 0 & 1 \\ 0 & 1 & 0 \\ 1 & 0 & 0 \end{bmatrix}$$

where $[Y_1]$ –consists of $(K \times K)$ identity matrices.

Notice, for the above expression the cross correlation between any two rows is always zero.

Step2, code segment: the representation of this matrix can be expressed as follows for $W=4$:

$$[Y_2] = \begin{bmatrix} 0 & 1 & 1 & 1 & 0 \\ 1 & 1 & 0 & 0 & 1 \\ 1 & 0 & 1 & 1 & 0 \end{bmatrix}$$

where $[Y_2]$ consists of two parts -weight matrix part $[W]$,and basics matrix part $[B]$. Basic part $[B]$ can be expressed as

$$[B] = \begin{bmatrix} 0 & 1 & 1 \\ 1 & 1 & 0 \\ 1 & 0 & 1 \end{bmatrix}$$

and weight part called $[M]$ matrix = $\begin{bmatrix} 1 & 0 \\ 0 & 1 \\ 1 & 0 \end{bmatrix}$ which is

responsible for increasing number of weights. Let $i = (W-3)$

and $M_i = \begin{bmatrix} 1 & 0 \\ 0 & 1 \\ 1 & 0 \end{bmatrix}$ where i represents number of M_i matrix on

matrix $[M]$, given by

$$[M] = \langle M_1 | M_2 | M_3, \dots, M_i \rangle \quad (1)$$

For example, if $W=5$, from Eq.(1) $i=2$, so that $[M] = \langle M_1 | M_2 \rangle$

$$[M] = \begin{bmatrix} 1 & 0 & 1 & 0 \\ 0 & 1 & 0 & 1 \\ 1 & 0 & 1 & 0 \end{bmatrix}$$

Notice that to increase the number of users simultaneously with the increase of code word length we can just repeat each row on both Matrixes $[M]$ and $[B]$. For K -th user matrix $[M]$ and $[B]$ can be expressed as

$$[B](j) = \begin{bmatrix} 0 & 1 & 1 \\ 1 & 1 & 0 \\ 1 & 0 & 1 \\ 0 & 1 & 1 \\ 1 & 1 & 0 \\ \vdots & \vdots & \vdots \\ \vdots & \vdots & \vdots \\ a_{j1} & a_{j2} & a_{j3} \end{bmatrix} \quad \text{and} \quad [M](j) = \begin{bmatrix} 0 & 1 \\ 1 & 0 \\ 0 & 1 \\ 1 & 0 \\ 0 & 1 \\ \vdots & \vdots \\ \vdots & \vdots \\ a_{j1} & a_{j2} \end{bmatrix}$$

where j represents the value for K -th user ($j=1,2,\dots,K$), and the value of a_j is either zero or one. The weights for code part for both matrix $[M]$, $[B]$ are equal to $W-1$, so the total combination of code is represented as $(K \times N)$ where $K=3$,

$N=8$, as given by $[Z_1]$, $[Z_1]=[Y_1 | Y_2]$

$$[Z_1] = \begin{bmatrix} 0 & 0 & 1 & 0 & 1 & 1 & 1 & 0 \\ 0 & 1 & 0 & 1 & 1 & 0 & 0 & 1 \\ 1 & 0 & 0 & 1 & 0 & 1 & 1 & 0 \end{bmatrix}$$

From the above basic matrix Z , determine the number of users (K) and the code length (N), as given by $(K \times N)$ matrix. Notice that the code weight of each row is equal to 4, and the relation between N and K for this case ($W=4$) can be expressed as

$$N = K + 5 \quad (2)$$

As a result we can find that for $W=5,6$, and 7 code, word length N can be expressed as $K+7$, $K+9$ and $K+11$ respectively. As a result the general equation describing number of users K , code length N and code weight W is given as

$$N = K + 2W - 3 \quad (3)$$

Finally, using the properties of RD code, the SNR for RD code is derived mathematically as follows:

$$SNR = \frac{\left(\frac{2\Re P_{sr} W}{N}\right)^2}{\frac{2eBWP_{sr}\Re}{N} + \frac{B\Re^2 P_{sr} W K}{2N^2 \Delta V} (K-1+W) + \frac{4K_B T_n B}{R_L}} \quad (4)$$

where P_{sr} is the effective power of a broadband source at the receiver. The bit-error rate (BER) can be calculated using Gaussian approximation [8]

$$BER = \frac{1}{2} \operatorname{erfc} \sqrt{\frac{SNR}{8}} \quad (5)$$

Table I shows the code lengths required by the different codes to support a number of users, K , of 30, RD code offers better performance than other codes in term of code length for same number of users. Short code length limit the addressing flexibility of the codes, while long code length are considered disadvantage in implementation, since either very wide – bandwidth source or very narrow filter bandwidth are required, RD codes exists for practical code length that are neither too short nor too long.

TABLE I
COMPARISON OF RD, MFH, OOC, HADAMARD AND PRIME CODES FOR THE SAME NUMBER OF USERS, K=30

Code	No. of user K	Weight W	Code length N
OCC	30	4	364
Prime code	30	31	961
Hadamard	30	16	32
MFH	30	7	42
RD code	30	3	33

III. OCDMA SYSTEM DESCRIPTION

Fig. 1 shows the setup of the proof-of-principle simulation for the proposed scheme. The performances of RD, MFH, and Hadamard codes are simulated by using the simulation software OptiSystem Version 6.0. A simple schematic block diagram consists of two users, as illustrated in Fig. 1. Each chip has a spectral width of 0.8 nm. The tests were carried out at a rate of 10 Gb/s for 20-km distance with the ITU-T G.652 standard single-mode optical fiber (SMF). All the attenuation α (i.e., 0.25 dB/km), dispersion (i.e., 18 ps/nm km), and nonlinear effects were activated and specified according to the typical industry values to simulate the real environment as close as possible. The performances of the system were characterized by referring to the bit-error rate (BER). As shown in Fig.1 after transmission, we used a Fibre Bragg grating (FBG) spectral phase decoder operates to decode the code at data level. The decoded signal was decoded by a photo-detector (PD) followed by a 0.75 GHz low-pass-filter (LPF) and error detector respectively. The transmitted power used was 0 dBm out of the broadband source. The noise generated at the receivers was set to be random and totally uncorrelated. The dark current value was 5 nA, and the thermal noise coefficient was 1.8×10^{-23} W/Hz for each of the photodetectors. The eye pattern diagrams for RD, Hadamard and MFH codes are shown in Fig. 2 respectively. The eyes diagram shown in Fig. 2 clearly depict that the RD code system gives better performance, having a larger eye opening. The corresponding simulated BER for RD, Hadamard, and MFH codes systems are shown in Fig. 2. The vertical distance between the top of the eye opening and maximum signal level gives the degree of distortion. The more the eye closes, the more difficult it is to distinguish between 1s and 0s in the signal. The height of the eye opening at the specified sampling time shows the noise margin or immunity to noise.

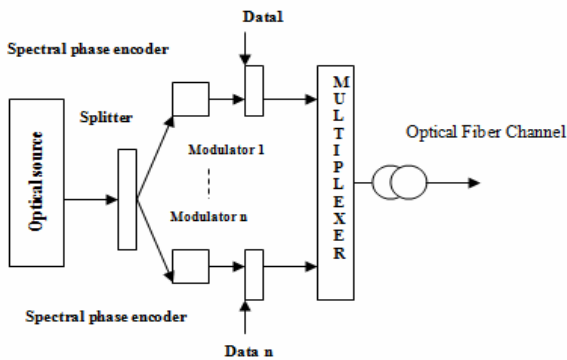

(a)

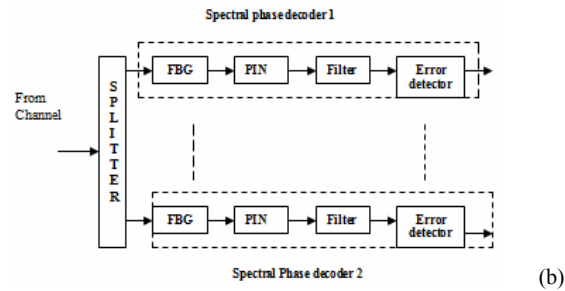

(b)

Fig. 1 Simulation setup of the proposed scheme (a) Transmitter (b) Receiver

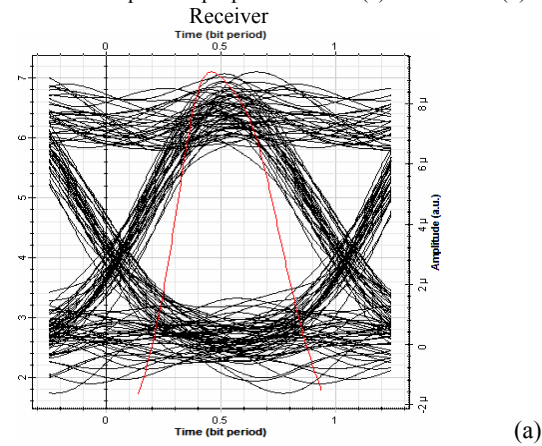

(a)

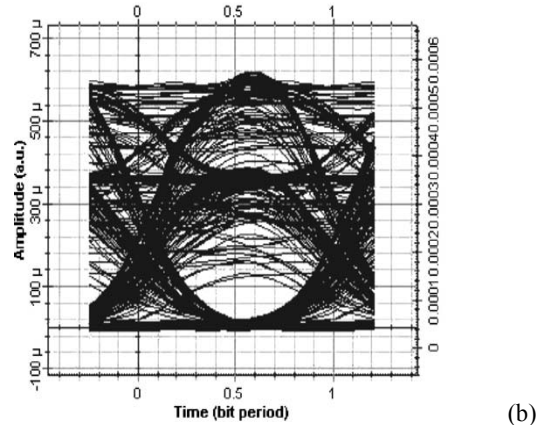

(b)

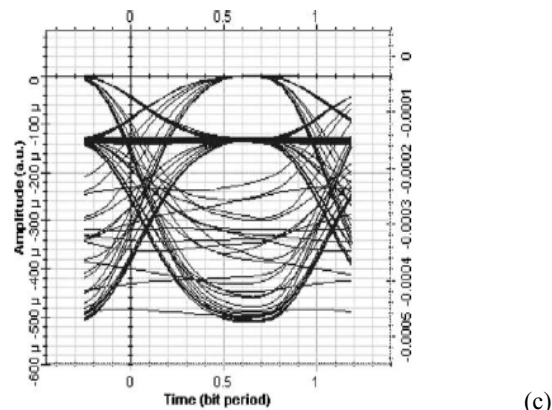

(c)

Fig. 2 Eye diagram of (a) one of the RD channels, (b) one of the Hadamard channels, and (c) one of the MFH channels, at 10 G bit/s

Using Eq. 4, Fig. 3 depicts the relation between the number of users and the BER, for RD, MFH, and Hadamard codes, where they have been plotted for different values of K (number of users). This figure clearly shows that RD code results in a much better performance, i.e (smaller BER) than MFH code and Hadamard code schemes. This is evident from the fact that RD code has a zero cross-correlation while Hadamard code has increasing value of cross-correlation as the number of users increases. Note also that the calculated BER for RD was achieved for $W=7$ while for MFH and Hadamard codes, the calculated BER was for $W=14$, and $W=64$ respectively.

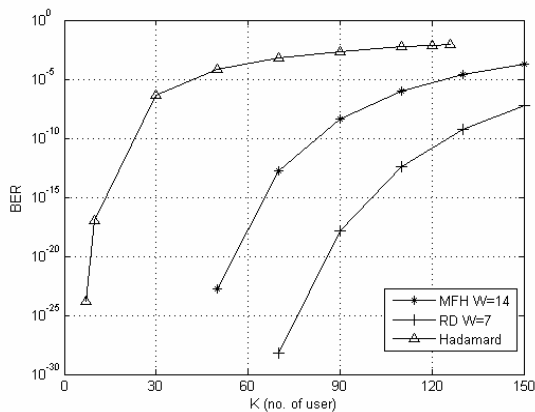

Fig. 3 BER versus number of users for RD, MFH and Hadamard code using $P_{sr} = 0$ dBm, $B = 80$ MHz at the operating wavelength of 1550 nm

In OCDMA systems, phase induced intensity noise (PIIN) is related to multiple access interference (MAI) due to the overlapping of spectra from different users. Here, we will analyze the relations between PIIN noise and received power. We have already shown previously that MAI can be almost reduced because of zero cross-correlation at data segment. Thus the effect of MAI is not elaborated further. Fig. 4 shows the relations between PIIN noise and received power (P_{sr}). The values of B , W , and ΔV are fixed (ie. $B = 311$ MHz, $W = 5$ and $\Delta V = 3.75$ THz) but P_{sr} varied from -30 dBm to 20 dBm. When the received power increases the PIIN noise for MFH and RD codes increases linearly. The PIIN noise of RD codes family is less compared to that of MFH code. As shown in Fig. 4 the PIIN noise can be effectively suppressed by using RD code family. This is because of the superior code properties of RD code family, such as no cross-correlation at data level. Also it has been shown that, when the numbers of users are increased, the PIIN noise increased as well.

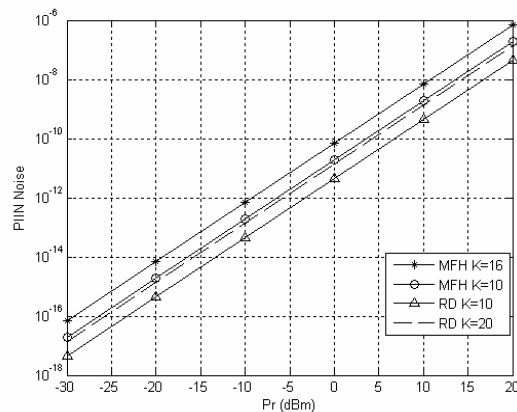

Fig. 4 PIIN versus P_r for versus OCDMA codes

IV. CONCLUSION

In this paper, we proposed a new code can effectively suppress the PIIN, with a fixed in-phase cross correlation value of 1 at code level and zero cross correlation at data level is presented. The properties of this code are described and discussed with the related equations. Based on the equations, the results of system performance are presented. To conclude, the advantages of the code can be summarized as follows: (1) shorter code length; (2) no cross-correlation in data level which minimized λ and reduced PIIN (Phase Induced Intensity Noise); (3) data level can be replaced with any type of codes; (4) more overlapping chips will result in more crosstalk; and (5) flexibility in choosing N , K parameters over other codes like MFH code. The performance of the system with the proposed RD code is analyzed by taking into account the effect of the intensity noise, shot, and thermal noise sources. It is found that RD code is the best in term of BER compared to MFH code and Hadamard code. RD code can be an excellent candidate for use in next-generation optical access networks.

REFERENCES

- [1] Kavehrad, M., and D. Zaccarin. 1995. Optical Code-Division-Multiplexed System Based on Spectral Encoding of Noncoherent Sources. *Journal Lightwave Technology*, 13: 534-545.
- [2] Yang, C. C., J. F. Huang, and S. P. Tseng. 2004. Optical CDMA Network Codecs Structured with M-Sequence Codes over Waveguide-Grating Routers. *IEEE Photonics Technology Letters*, 16 (2): 641-643.
- [3] Z. Wei and H. Ghafouri-Shiraz, "Proposal of a novel code for spectral amplitude-coding optical CDMA systems," *IEEE Photon. Technol. Lett.*, vol. 14, pp. 414-416, Mar. 2002.
- [4] Z. Wei et al., "Modified quadratic congruence codes for fiber Bragg-grating-based spectral-amplitude-coding optical CDMA systems," *J. Lightwave Technol.*, vol. 19, pp. 1274-1281, Sept. 2001.
- [5] F. R. K. Chung et al., "Optical orthogonal codes: design, analysis, and applications," *IEEE Trans. Inform. Technol.*, vol. 35, pp. 595-604, May 1989.
- [6] Goursaud C., Julien-Vergonjanne A., Aupetit-Berthelemot C., Cances J.P. and Dumas J.M., "Study of Parallel Interference Cancellation Structures for Incoherent DSOCMA Systems", *Asia-Pacific Conference on Communication*, Oct 2005.
- [7] S. Zahedi and J. A. Salehi, "Analytical comparison of various fiber optic CDMA receiver structures," *J. Lightw. Technol.*, Vol 18, no. 5, pp.1718-1727, Dec.2000.
- [8] J. W. Goodman, *Statistical Optics*. New York: Wiley 1995