

# Performance Enhancement of Membrane Distillation Process in Fruit Juice Concentration by Membrane Surface Modification

Samir K. Deshmukh, Mayur M. Tajane

**Abstract**—In this work Membrane Distillation is applied to concentrate orange Juice. Clarified orange juice (11° Brix) obtained from fresh fruits and a sugar solution was subjected to membrane distillation. The experiments were performed on a flat sheet module using orange juice and sucrose solution as feeds. The concentration of a sucrose solution, used as a model fruit juice and also orange juice, was carried out in a direct contact membrane distillation using hydrophobic PTFE membrane of pore size 0.2  $\mu\text{m}$  and porosity 70%. Surface modification of PTFE membrane has been carried out by treating membrane with alcohol and water solution to make it hydrophilic and then hydrophobicity was regained by drying. The influences of the feed temperature, feed concentration, flow rate, operating time on the permeate flux were studied for treated and non treated membrane. In this work treated and non treated membrane were compared in terms of water flux. Within the tested range, MD with surface modified membrane the water flux has been significantly improved by treating the membrane surface.

**Keywords**—Membrane Distillation, Surface Modification, Orange Juice. Polytetrafluoroethylene.

## I. INTRODUCTION

MEMBRANE distillation (MD) is a membrane technique that involves transport of water vapor through the pores of hydrophobic membranes due to a vapor pressure driving force provided by temperature and/or solute concentration differences across the membrane. A variety of methods may be employed to impose this vapor pressure difference [1], [2], [3], [4], [5], [6], [7]. In the present work, the direct contact membrane distillation method is considered. In this configuration the surfaces of the membrane are in direct contact with two liquid phases, the feed (warm solution) and the permeate (cold solution), kept at different temperatures. A liquid vapor interface exists at the pore entrances where liquid-vapor equilibrium is established. Inside the pores only a gaseous phase is present through which vapor is transported as long as a partial pressure difference is maintained. The vaporization takes place at the feed membrane interface. The

vapor diffuses through the membrane pores and condenses at the permeate membrane interface. Thus, MD relies on vapor-liquid equilibrium as a basis for separation and requires that the latent heat of vaporization be supplied to achieve the characteristic phase change. Membrane distillation offers advantages like techniques suitable for heat-sensitive products, modularity, easy scale-up, possibility to treat solutions with high level of suspended solids, Possibility of using modules in series, low temperatures, low operating pressures, no fouling problems, constant permeate flux in time, new technologies based on the use of conventional well-tested materials and low investment cost. Drawbacks of the process can be compensating by enhancing the flux rate. This technology work with certain disadvantages like low evaporative capacity with a long time of treatment, necessity of an inactivation enzyme pre-treatment and low flux rate. The goal of the present article is to enhance flux rate by surface modification of membrane surface to make process more efficient and commercially viable.

DCMD is not a simple process of mass transfer through the membrane, but a complex process combination of several interrelated heat and mass transfer steps. In fact, as vaporization takes place at the feed membrane interface and condensation at the permeate membrane interface, membrane distillation requires the heat of vaporization to be supplied to the feed vapor-liquid interface, and the heat of condensation to be removed from the vapor-liquid interface in the permeate side. Conductive heat transport through the thin membrane also takes place. As a consequence, thermal boundary layers develop at both sides of the membrane, that is, temperature polarization arises. On the other hand, concentration boundary layers develop in the liquid phases (that is, concentration polarization arises) if there is solute rejection by the membrane [7].

Orange juice is probably the best known and most widespread fruit juice all over the world, particularly appreciated for its fresh flavour and considered of high beneficial value for its high content in vitamin C and natural antioxidants, such as flavonoids and phenylpropanoids. The advantages of the concentration of the liquid foodstuffs include the reduction in packaging, storage, transport cost and prevention of deterioration by microorganisms. For these reasons, many concentration techniques have been developed and used for the food industries. They include evaporative concentration, freeze concentration, and membrane processes

---

Samir K. Deshmukh, is with Jawaharlal Darda Institute of Engineering and Technology, Yavatmal, Maharashtra State, 445001, India. He is now with the Department of Chemical Engineering, affiliated to, Sant Gadge Baba Amravati University, Amravati, Contact No. + 91 9763717422

(e-mail:samirdesh23@yahoo.com).

Mayur M. Tajane., is with Jawaharlal Darda Institute of Engineering and Technology, Yavatmal, Maharashtra State, 445001, India. The College is affiliated to Sant Gadge Baba Amravati University, Amravati.,

Contact No. + 91 9545516577; e-mail: mmtajane21@rediffmail.com)

such as reverse osmosis (RO) and ultrafiltration (UF)[9], [10].

Nevertheless, when concentration is carried out by traditional multi step vacuum evaporation, a severe loss of the volatile organic flavour/fragrance components occurs as well as a partial degradation of ascorbic acid and natural antioxidants, accompanied by a certain discolouration and a consequent qualitative decline. These effects are mainly attributable to heat transfer to the juice during evaporation. In order to overcome some of these problems and to better preserve the properties of the fresh fruits, several new "mild" technological processes have been proposed in the last years for juice production.[8] MD has many significant advantages, such as high system compactness, possibility to operate at low temperatures (30–90°C) which makes it amenable for use with low temperature heat sources, including waste or solar heat, and, when compared with say reverse osmosis or electrodialysis, the simplicity of the membrane which allows it to be manufactured from a wide choice of chemically and thermally resistant materials, and much larger pores than of reverse osmosis membranes (and typically larger than in ultrafiltration membranes, that aren't nearly as sensitive to fouling. [1], [12]

## II. MATERIAL AND METHODOLOGY

### A. Module Development

Cross flow module of hydrophobic PTFE 0.2µm has been developed with the help of viton gasket, polyester mesh and adhesive. Module has length 11.5cm, breadth 10 cm and hydraulic diameter 2.28 mm is supported with stainless steel holding device. Module has effective membrane area 0.0115m<sup>2</sup>.

TABLE I MODULE CONFIGURATION

Module	
Configuration	Flat Plate
Membrane area, m <sup>2</sup>	0.0115
Material	PTFE
Membrane thickness,	160 µm
Nominal pore diameter,	0.05 – 0.2 µm
Porosity (%)	70

### B. Treatment of PTFE membrane:

The membrane was treated by circulating 20% ethyl alcohol water mixture for half an hour, which makes an membrane hydrophilic and again dried to make it hydrophobic. This treatment modified the surface of the membrane.

### C. Orange Juice Samples

Marmalade orange were purchased from a local market. Fruits (47) were manually washed in water and then peeled by hand, with a knife, obtaining 4.06 kg of peeled fruits (yield 47.1%). Seeds and mesocarp fibres were removed with a squeezer and then washed with water. Orange juice is obtained by squeezing, TSS concentration of the raw juice was about 11.0–11.6° Bx with a pH = 3.5 and vitamin c is 368.64 PPM.

Orange juice of 11 .5° Brix is used as feed. The suspended matter was removed from juice by using masline cloth, filter paper and through wattman filter paper no. 40 for primary filtration and Sodium azide (Aldrich, Germany) was added to both sucrose and orange juice solutions (0.2% w/w), in order to prevent their fermentation during the experiments.

### D. Sugar Solution

The orange juice model solution used in this study was prepared with sucrose pro-analysis grade (Riedel-deHaën, Germany), citral (cis and trans mixture, 95%) and ethyl butyrate, 98% (Aldrich, Germany).

TABLE II OBSERVATION OF CHEMICAL AND PHYSICAL TESTS

No. of oranges	47	36
Wt. of pulp	0.976 kg	0.571 kg
Wt. of juice	2.883 kg	1.582 kg
Total wt.	4.06 kg	2.486 kg
Brix	11.6	12.00
pH	3.5	3.5
Sp. Gravity	1.04	1.04
Total solid	90.50%	89.79%
Insoluble solid	90.10%	90%
Dye factor	0.096	0.096
Mg of ascorbic acid present	368.64 ppm	345.66 ppm

## III. EXPERIMENTAL SET UP

Concentration of clarified orange juice and sugar solution by DCMD was carried out using a flat-sheet membrane cell with an effective membrane area 0.0115 m<sup>2</sup>. The membrane cell was made of stainless steel and was placed in a vertical configuration. The system to be studied consists of a porous hydrophobic membrane, which is held between two symmetric channels. Hot feed is circulated through one of the channels and cold permeate through the other one. The hot and cold fluids counter-flow tangentially to the membrane surface in a flat membrane module. In our experiments, the membrane is sandwiched between two equal stainless steel manifolds. Microporous hydrophobic PTFE membrane of 0.2 µm pore size and thickness 160 µm was placed between polyester mesh (0.28mm), polyviton gasket (3 mm) on both side which create the two identical flow channels, the membrane and the manifolds create spacer-filled flow channels for hot feed and cold permeate liquids.

Feed tank with thermostat, peristaltic pump and temperature and flow indicator is arrange in feed side, where as peristaltic pump, and temperature and flow indicator is arrange in permeate side. Module is supported with stainless steel holding device. The schematic arrangement is shown in Fig.1. Clarified juice as feed solution and distilled water as receiving phase were contained in two jacketed reservoirs and were circulated through the membrane cell by one two-channel peristaltic pump. The feed and distillate streams flow counter currently from the bottom to the upper part of the membrane cell. Different experiments were carried out for fixed temperatures in the membrane module. The average feed

temperature  $T_f$  varied for the different experiments from 40 to 70°C and permeates temperature  $T_p$  varied for the different experiments from 20 to 30°C.

The linear velocity feed and permeate was also varied. Different experiments were carried out applying different recirculation rates. A drainage tube in the upper part of the receiving reservoir confined the total volume of receiving phase to about 100 ml. Excessive liquid due to permeate transferred across the membrane escaped from receiving reservoir and was collected in a graduated cylinder. The permeate volume was measured continuously as a function of time and these data were used for calculation of the permeate flux.

viscous flow, Knudsen and molecular diffusion. If we have a porous media or a porous membrane filled by a gas mixture and a pressure gradient exists through the membrane, a form for the flux relations can be obtained, modeling the porous medium as a bundle of cylindrical capillaries and using momentum transfer considerations. The flux relations are, of course, founded on transport laws for a single capillary. According to mentioned transfer considerations, encounters between molecules or between a molecule and the capillary walls are accompanied by momentum transfer. As a result, there are three mechanisms, by which a given species of a gas mixture may lose momentum in the motion direction through a capillary available in literature each consider one or more of the following mass transfer mechanism across the membrane:

(a) by a direct transfer to the capillary walls as a result of molecule-wall collisions (Knudsen resistance); (b) by transfer to another species as a consequence of collisions between pairs of unlike molecules molecular resistance); (c) by indirect transfer to the capillary walls via a sequence of molecule-molecule collisions terminating in a molecule-wall collision (viscous resistance).

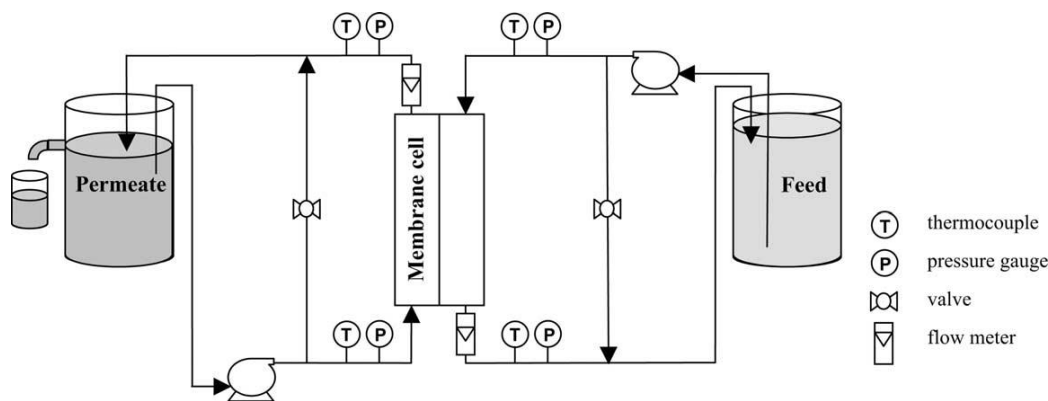

Fig. 1 Flow Diagram of Membrane Distillation

IV. THEORY

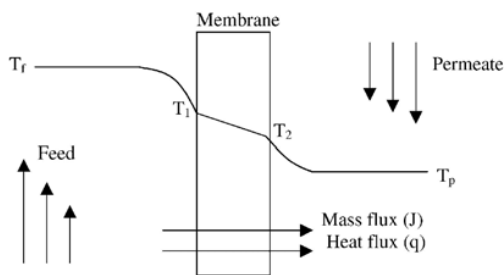

Fig. 1 (a) Heat transfer along membrane surface

A. Mass Transfer

Modeling of mass (vapor) transfer within the membrane pores has received most interest from Membrane Distillation investigators. Several Membrane Distillation model are any

theoretical study of gas permeation through microporous structures begins with a comparison of the mean free path of the gas and the mean pore size of the structure. If the mean free path of the gas is much less than the pore size, then the dominant flux mechanism is viscous or Poiseuille flow. If the mean free path is much greater than the pore size, then Knudsen diffusion is the dominant mechanism.

Knudsen number, which is the ratio of mean free path and pore diameter, dictate the type of mass transfer mechanism. If Knudsen number is less than 0.01, the mass transfer mechanism is considered as molecular diffusion and Kn values higher than 10, the mechanism is considered as Knudsen diffusion. If the values of Kn lies between 0.01 – 10, it is the transition zone and both the mechanism contribute to the mass transfer.

$$Kn = \frac{\lambda}{2r} \tag{1}$$

Kn is Knudsen number and  $\lambda$  is mean free path.

Mean free path is given by equation

$$\lambda = \frac{3.2 \mu_v}{P} \sqrt{\frac{RT}{2\pi M}} \quad (2)$$

Where  $\mu_v$  is viscosity of vapors at atmospheric temperature and ambient pressure

If the ratio  $d/\lambda$  (pore diameter to mean free path of the gas molecule  $\lambda$ ) is greater than 20, molecular diffusion is predominant, the molar flux is given by:

$$N_A = \frac{N_A}{N_A + N_B} \left( \frac{D_{eff} P_t}{RT\chi} \right) \ln \left( \frac{\frac{N_A}{N_A + N_B} - y_{A2}}{\frac{N_A}{N_A + N_B} - y_{A1}} \right) \quad (3)$$

Where,

$$D_{eff} = D_{AB} \frac{\varepsilon}{\chi} \quad (4)$$

If the ratio  $d/\lambda < 0.2$  the rate of diffusion is governed by the collision of the gas molecules within the pore walls and follow Knudsen law, the mass flux is given by:

$$J = \frac{D_K (P_{A1} - P_{A2})}{RT\chi} \quad (5)$$

Where,

$$D_K = \left( \frac{d}{3} \right) \left( \frac{8g_c RT}{\pi M} \right)^{1/2} \quad (6)$$

If  $0.2 < d/\lambda < 20$ , both molecular and Knudsen diffusion takes place.

$$N_A = \frac{N_A}{N_A + N_B} \left( \frac{D_{eff} P_t}{RT\chi} \right) \ln \left( \frac{\left( \frac{N_A}{N_A + N_B} \right) \left( 1 + \frac{D_{eff}}{D_{Keff}} \right) - y_{A2}}{\left( \frac{N_A}{N_A + N_B} \right) \left( 1 + \frac{D_{eff}}{D_{Keff}} \right) - y_{A1}} \right) \quad (7)$$

Rate of mass transfer in membrane distillation for laminar flow, recognizing that the transport regime would be in the Knudsen and Poiseuille transition is given by:

$$J = \frac{\varepsilon M D_{KP}}{\chi RT} \ln \frac{P - P_{ip}}{P - P_{if}} \quad (8)$$

$$D_{KP} = \left( \frac{1}{D_K} + \frac{1}{D_p} \right)^{-1} \quad (9)$$

### B. Heat Transfer

The heat transfer equations governing heat flows in and around the membrane are:

Neglecting the heat flux that occurs due to concentration gradient and the possible radiative heat flux, the total heat flux from the feed bulk to the membrane can be written as

$$Q_f'' = h_f (T_f - T_1) \quad (16)$$

The heat transfer inside the membrane is divided into two possible mechanism, conduction across the membrane material together with the heat flowing through the membrane. With the assumption of nonlinear temperature distribution and non-isenthalpic flow, the heat transfer equation inside the membrane is given by:

$$Q_m'' = Q_v'' + Q_c'' \quad (17)$$

$$J \Delta H_v + (k_m/\delta) (T_1 - T_2)$$

Where,  $\Delta H_v$  is the vapor enthalpy at temperature T and  $k_m$  is the thermal conductivity coefficient which can be determine on the basis of membrane material data:

$$Q_c'' = (k_m/\delta) (T_1 - T_2) = h_m (T_1 - T_2) \quad (18)$$

Thermal conductivity of membrane is given by:

$$k_m = k_g \varepsilon + (1 - \varepsilon) k_s \quad (19)$$

$$h_m = (\varepsilon K_g + (1 - \varepsilon) K_s) / \delta \quad (20)$$

$$Q_v'' = J \Delta H_v = h_v \Delta T_m = h_v (T_1 - T_2) \quad (21)$$

$$H_v(T) = H_v(T_0) + C_{pv}(T - T_0) \quad (22)$$

Where  $H_v(T_0)$  is the heat vaporization at reference temperature  $T_0$  and  $C_{pv}$  is specific heat of vapor. Generally, the reference temperature ( $T_0$ ) is 273 K. With the vapor-liquid equilibrium assumption, the thermodynamic properties can be applied. For water vapor,  $C_{pv} = 1.7535$  KJ/Kg K for the range of temperature 0 – 100°C and  $(H_v \times 273.15) - (C_{pv} \times 273.15) = 2024.3$  KJ/Kg.

Then equation 22 can be written as:

$$H_v(T) = 1,7535 (T) + 2024.3 \quad (23)$$

The total heat flux from the membrane to the bulk permeates can be written as:

$$Q_p'' = h_p (T_2 - T_p) \quad (24)$$

The film heat transfer coefficients can be estimated from appropriate correlations or may be determined experimentally.

## V. RESULT AND DISCUSSION

## A. Effect of Feed Velocity

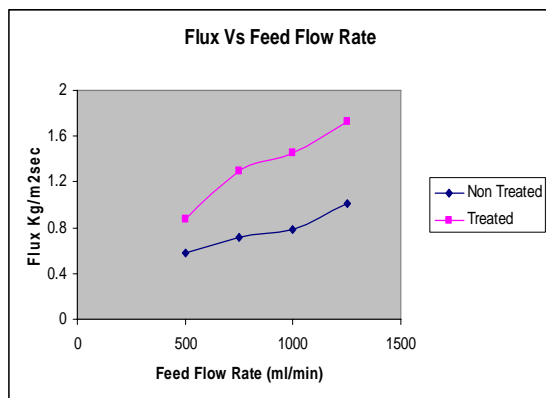

Fig. 2 Effect of feed velocity on transmembrane flux using PTFE membrane (Permeate flow rate 1000ml/min, Feed temperature 50 °C, permeate temperature 30 °C and 11.5 °Brix)

Effect of feed flow rate on transmembrane flux for sugar solution is estimated for both treated and nontreated membrane and presented in Fig. 2. During experiments, the feed side flow rate is varied and permeate side flow rate (500ml/min), temperature difference ( $\Delta T = 20^\circ\text{C}$ ), and concentration was maintained constant (11.5 °Bx). The transmembrane flux in both case increases with increase in flow rate. The increase is mainly due to the reduction in temperature polarization. The increase in case of treated membrane resulted in 36 – 43% increase in flux.

## B. Effect of Feed concentration

The concentration of sugar solution was varied over 7 – 22 °Brix. During the experiments the feed flow rate, permeate flow rate and temperature difference are maintained constant. The values of transmembrane flux observed at different concentration of feed solution are shown in Fig. 3 The transmembrane flux for both treated and nontreated decreases with increase in concentration.

## C. Effect of temperature difference

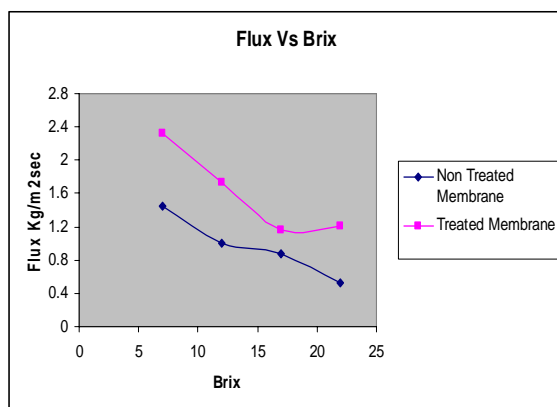

Fig. 3 Effect of concentration on flux using PTFE membrane ( Feed flow rate 1200ml/min, Permeate flow rate 1000ml/min, Feed temperature 50 °C, permeate temperature 30 °C )

Fig. 4 shows the results obtained at four constant temperatures of juice in the hot cell (40°C, 50°C, 60°C and 70°C) with constant cold cell temperatures. During experiments the feed and permeate velocity were maintained constant. Flux measurements were taken every 15 min. The flux was calculated based on experimental data using the following equation.

$$J = \frac{\text{measured permeate flow rate}}{\text{membrane area}}$$

The fluxes exhibit an exponential dependence on temperature—as would be expected when considering the Antoine equation for vapor pressure of water:

$$p_{mi} = \exp\left(23.238 - \frac{3841}{T_{mi} - 45}\right), i = 1, 2$$

where  $p$  is the vapor pressure of water in Pa and  $T$  is the temperature in K.

The flux increased exponentially with temperature. The temperature difference creates vapor pressure difference and thus the membrane distillation flux rises.

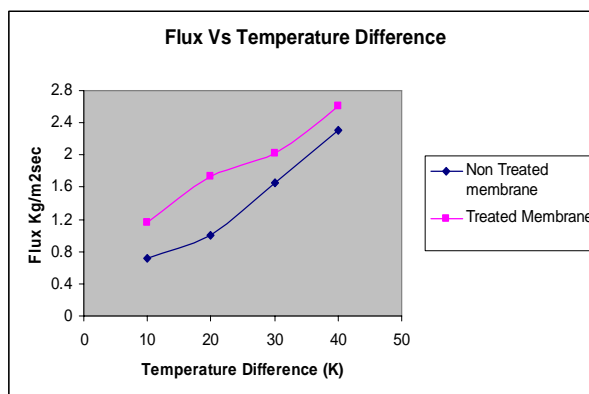

Fig. 4 Effect of  $\Delta T$  on transmembrane flux using PTFE membrane (Feed flow rate 1200ml/min, Permeate flow rate 1000ml/min, permeate temperature 30 °C and 11.5 °Brix)

## VI. CONCLUSION

The concentration of sugar solution as a model orange juice was carried out by direct contact membrane distillation for both treated and non treated PTFE membrane. The influence of various parameters such as feed flow rate, temperature difference, and concentration of sugar solution with respect to transmembrane flux were studied for real system. It was observed that transmembrane flux for treated membrane was 36 – 43% more than nontreated membrane. The experiments were performed to study the flux decay in membrane distillation for treated membrane for different concentration.

## REFERENCES

- [1] K.W. Lawson, D.R. Lloyd, Membrane distillation, J. Membr. Sci. 124(1997) 1–25.
- [2] R.W. Schofield, A.G. Fane, C.J.D. Fell, Heat and mass transfer in membrane distillation, J. Membr. Sci. 33 (1987) 299–313.

- [3] M. Khayet, M.P. Godino, J.I. Mengual, Theory and experiments on sweeping gas membrane distillation, *J. Membr. Sci.* 165 (2000) 261–272.
- [4] F.A. Banat, J. Simandl, Theoretical and experimental study in membrane distillation, *Desalination* 95 (1994) 39–52.
- [5] S. Bandini, C. Gostoli, G.C. Sarti, Separation efficiency in vacuum membrane distillation, *J. Membr. Sci.* 73 (1992) 217–229.
- [6] L. Martínez, J.M. Rodríguez-Maroto, On transport resistances in direct contact membrane distillation, *Journal of Membrane Science* 295 (2007) 28–39.
- [7] Gianni Galaverna, Gianluca Di Silvestro, Alfredo Cassano, Stefano Sforza, Arnaldo Dossena, Enrico Drioli, Rosangela Marchelli, A new integrated membrane process for the production of concentrated blood orange juice: Effect on bioactive compounds and antioxidant activity, *Food chemistry* 2007.
- [8] Thanedgunbaworn, R. Jiratananon, M.H. Nguyen, Mass and heat transfer analysis in fructose concentration by osmotic distillation process using hollow fibre module, *Journal of Food Engineering* 78 (2007) 126–135.
- [9] Rico Bagger-Jørgensen a, Anne S. Meyer a\*, Camilla Varming b, Gunnar Jonsson, Recovery of volatile aroma compounds from black currant juice by vacuum membrane distillation, *Journal of Food Engineering* 64 (2004) 23–31.
- [10] A.M. Alkhalabi, Noam Lior, Transport analysis of air-gap membrane distillation, *Journal of Membrane Science* 255 (2005) 239–253