

Performance Analysis of Selective Adaptive Multiple Access Interference Cancellation for Multicarrier DS-CDMA Systems

Maged Ahmed and Ahmed El-Mahdy

Abstract—In this paper, Selective Adaptive Parallel Interference Cancellation (SA-PIC) technique is presented for Multicarrier Direct Sequence Code Division Multiple Access (MC DS-CDMA) scheme. The motivation of using SA-PIC is that it gives high performance and at the same time, reduces the computational complexity required to perform interference cancellation. An upper bound expression of the bit error rate (BER) for the SA-PIC under Rayleigh fading channel condition is derived. Moreover, the implementation complexities for SA-PIC and Adaptive Parallel Interference Cancellation (APIC) are discussed and compared. The performance of SA-PIC is investigated analytically and validated via computer simulations.

Keywords—Adaptive interference cancellation, communication systems, multicarrier signal processing, spread spectrum

I. INTRODUCTION

MANY multiuser Detectors (MUD) algorithms have been proposed in the literature to eliminate the multiple access interference (MAI). These algorithms are classified into two major approaches, namely, adaptive filtering[1][2] and Interference Cancellation (IC) [3],[4]. Much more research has been dedicated to the latter primarily due to simpler analysis tractability. There are two main varieties of IC schemes, Serial Interference Cancellation (SIC), and Parallel Interference Cancellation (PIC) [5][6]. PIC can be classified into two categories, linear PIC (LPIC), and non Linear PIC. Under assumption of perfect channel estimation, the non Linear PIC outperforms the LPIC. An extension to PIC, called partial parallel interference cancellation (PPIC), has been proposed in [7]. In this scheme, it has been shown that if interference is removed partially at each stage, the performance of the system would be significantly better than complete cancellation. One problem of this approach is that the computational complexity is high in time-varying environments. Also, when the required statistics are not properly estimated, the performance may be seriously affected. To remedy the problem, an adaptive approach using

the Least Mean Square (LMS) algorithm was then proposed for partial PICs.[8]. There are many advantages using the adaptive PIC [9]. It is inherently applicable in time-varying environments. Also, it does not have to conduct robust channel estimation, and its performance is better than non adaptive. As in [10], the adaptive multistage PIC was applied to multi-rate systems. S-PIC, and SA-PIC schemes were introduced with CDMA in [11], and [12] respectively. The performance of these schemes were evaluated with computer simulation, it has been found that both schemes have good performance in terms of bit error rate (BER), with low implementation complexity relative to conventional PIC and APIC. An upper bound of the BER of S-PIC scheme in a typical DS-CDMA communication system has been introduced[13]. For MC DS-CDMA many of MUD schemes have been developed to mitigate degradation of its performance as MAI increased[14]-[16]. One of the most promising schemes is the APIC scheme which was introduced for MC DS-CDMA in [17]. The major drawback of this system is its complexity, since weights are needed to be calculated for all sub-carriers and users of the system. According to this literature review, the use of SA-PIC with MC DS-CDMA has not been studied before. In this paper, the SA-PIC is applied to MC DS-CDMA and the performance of MC DS-CDMA using SA-PIC is studied and analyzed. Moreover, an upper bound expression of the BER for the SA-PIC under Rayleigh fading channel condition is derived. Finally the implementation complexities for SA-PIC and APIC are discussed and compared. The rest of this paper is organized as follows. In Section 2, the MC DS-CDMA system is introduced. In Sections 3, selective adaptive parallel interference cancellation is presented while its performance in terms of BER is evaluated in Section 4. Simulation results are shown in Section 5. Finally, conclusions are presented in Section 6.

II. SYSTEM MODEL

The transmitter block diagram for the orthogonal MC DS-CDMA system of user k is shown in Fig. 1. In this scheme the initial data stream having the bit duration of T_b is Serial to Parallel converted to p number of lower-rate substreams, hence the new bit duration after the s/p conversion or the symbol duration is $T_s = p T_b$. Each of the p lower-rate substreams is spread by the time-domain spreading

Maged Ahmed, is Ph.D student in Electrical Engineering Depart., MTC, Cairo, Egypt (e-mail: maged-ohammed@excite.com).

Ahmed El-Mahdy is with the German University in Cairo, Egypt (phone: +202 27595565; fax:+202 27581041; e-mail: ahmed.elmahdy@guc.edu.eg).

code $c^k(t)$, which is a purely random PN code. Each of the p substreams is transmitted by M number of subcarriers, in order to achieve a frequency diversity of order M at the receiver by

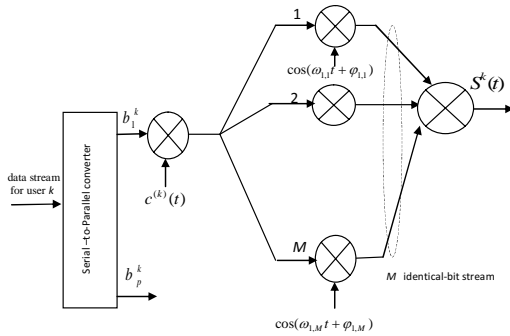

Fig.1. Transmitter block diagram of the orthogonal MC DS-CDMA system for the k th user

combining these subcarrier signals with the aid of certain types of combining scheme. Hence, the total number of subcarriers required by the orthogonal MC DS-CDMA system is $U = pM$. Based on this, the transmitted signal of user k can be modeled as [18]

$$s_k(t) = \sum_{i=1}^p \sum_{j=1}^M \sqrt{\frac{2P_k}{M}} b_i^{(k)}(t) c^k(t) \cos(2\pi f_{ij} t + \phi_{ij}^k) \quad (1)$$

where P_k is the transmitted power of the k^{th} user, $b_i^{(k)}(t) = \sum_{n=-\infty}^{\infty} b_i^k[n] P_{T_s}(t - nT_s)$, $i=1, 2, \dots, P$ represents the binary data of the i^{th} substream, $b_i^k[n]$ is assumed to be random variable taking value of ± 1 with equal probability, while $P_{T_s}(t)$ represents the rectangular shape waveform, and $c^k(t)$ represents the T domain spreading code assigned to the user k , which is the same for all the $U = pM$ number of subcarriers. The spreading sequence $c^k(t)$ can be expressed as $c^k(t) = \sum_{\ell=-\infty}^{\infty} c_\ell^k P_{T_c}(t - \ell T_c)$, where c_ℓ^k assumes values of ± 1 , while P_{T_c} is the chip waveform of the T domain spreading sequence, which is defined over the interval $[0, T_c)$, finally, ϕ_{ij}^k represents the initial phase associated with the carrier modulation in the context of the subcarrier determined by (i, j) in (1). The channel is assumed to be a slow varying, frequency-selective Rayleigh fading channel with a delay spread of T_m . The principle motivation for using MC-CDMA is to allow a frequency selective fading channel to appear as flat fading on each subcarrier, assuming the number of subcarrier is sufficiently large [18]. With this assumption, each subcarrier experiences a complex flat-fading channel with transfer function for the subcarrier (i, j) of the user k can be defined as

$$\zeta_{ij}^{(k)}(t) = \alpha_{ij}^k(t) \exp[j\psi_{ij}^{(k)}(t)], \quad (2)$$

where $\alpha_{ij}^k(t)$ is a Rayleigh-distributed stochastic process with

unit second moment, and $\psi_{ij}^{(k)}(t)$ is uniformly distributed over $(0, 2\pi]$. It is assumed that the channel transfer function $\zeta_{ij}^{(k)}(t)$ is independent and identically distributed (i.i.d.) for different values of k and (i, j) . The system model is assumed to be a synchronous MC DS-CDMA system with BPSK modulation to considerably simplify the exposition and analysis. Synchronous systems are becoming more of practical interest since quasi-synchronous approach has been proposed for satellite and microcell applications [17][19].

Assuming that the system consists of K synchronous users, and the user of $k=ii$ is the reference one. The proposed receiver block diagram of the reference user is shown in Fig. 2. All users use the same $U = pM$ subcarriers, the average power received from each user at

the base station is also assumed to be the same, implying perfect power control. When the transmitted signal is in the form of (1), the received signal at the base station can be expressed as [18]

$$r(t) = \sum_{k=1}^K \sum_{i=1}^p \sum_{j=1}^M \sqrt{\frac{2P}{M}} \alpha_{ij}^k b_i^k(t) c_k(t) \cos(2\pi f_{ij} t + \phi_{ij}^k) + n(t), \quad (3)$$

where $\phi_{ij}^k = \phi_{ij}^k - \psi_{ij}^k$, is assumed to be an i.i.d random variable having a uniform distribution in $[0, 2\pi)$, $n(t)$ represents the AWGN with zero mean and double-sided PSD of variance $N_0/2$. The receiver provides a coherent correlator for each subcarrier and the correlator outputs associated with the same data bit are combined to form a decision variable. Assuming that the receiver is capable of tracking the carrier phases of the subcarrier signals of the reference user, therefore, ϕ_{ij}^{ii} is set = 0. The superscripts and subscripts concerning the reference user will be omitted for the sake of simplicity. For Maximal Ratio Combining (MRC) the decision variable for detecting bit u for the reference user b_u can be written as

$$\begin{aligned} Z_u &= \sum_{v=1}^M Z_{uv} \\ &= D_{uv} + N_{uv} + \sum_{\substack{k=1 \\ k \neq ii}}^K I_1^{(k)}, \end{aligned} \quad (4)$$

where $Z_{uv} = \int_0^{T_s} r(t) g_{uv} c(t) \cos(2\pi f_{uv} t) dt$.

Giving that, $g_{uv} = \alpha_{uv}$ is assumed, associated with perfect channel estimation and a MRC diversity combining scheme, hence the desired signal D_{uv} is given by

$$D_{uv} = \sqrt{\frac{2P}{M}} \frac{\alpha_{uv}^2}{2} \int_0^{T_s} b_u(t) dt = \sqrt{\frac{P}{2M}} g_{uv}^2 b_u T_s. \quad (5)$$

The noise term N_{uv} has a zero mean Gaussian random

variable and its variance is given by $\sigma_n^2 = \frac{N_0}{4} \sum_{v=1}^M [g_{uv}^2]$.

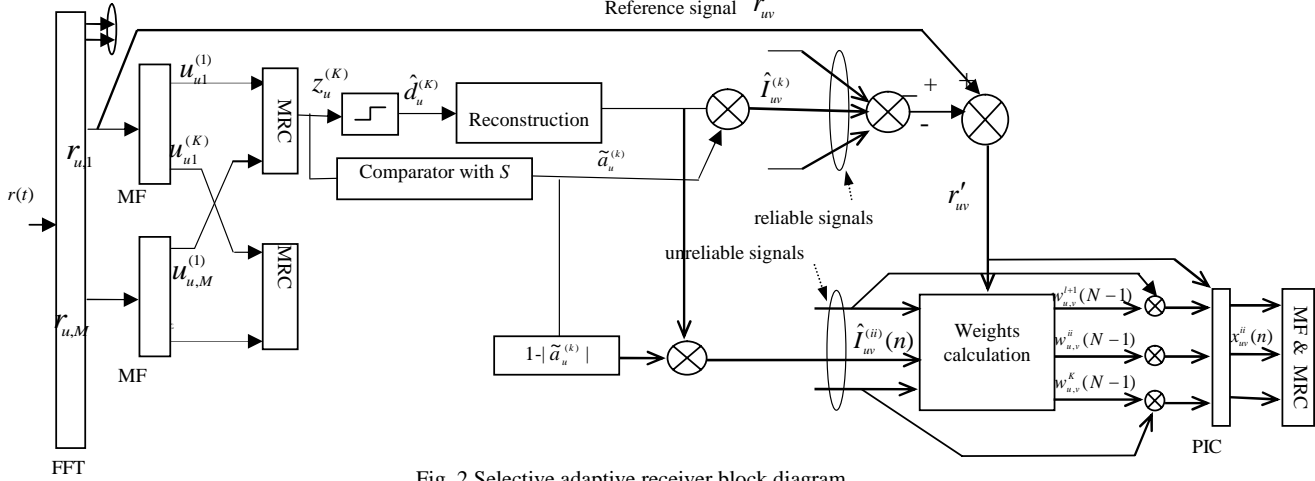

Fig. 2 Selective adaptive receiver block diagram

For Synchronous MC-DS-CDMA system, the multiuser interference from other subcarriers is simply vanishes due to orthogonality between subcarriers, while the source of multiuser interference comes from other users on the same considered subcarrier $I_1^{(k)}$, which can be written as

$$I_1^{(k)} = \sqrt{\frac{2P_k}{M}} \frac{\alpha_{uv}^k g_{uv}}{2} \cos(\varphi_{uv}^k) \int_0^{T_s} b_u^k(t) c_k(t) c(t) dt$$

$$= \sqrt{\frac{P_k}{2M}} \alpha_{uv}^k g_{uv} \cos(\varphi_{uv}^k) b_u^k \rho_{ii,k}, \quad (6)$$

where $\rho_{ii,k}$ is the correlation coefficient between the signature waveforms of the user of interest ($k=ii$) and the user k for the u^{th} subcarrier.

III. MC-CDMA WITH SELECTIVE ADAPTIVE PARALLEL INTERFERENCE CANCELLATION

The selective APIC is based on dividing users signals into reliable and unreliable signals. The M outputs of matched filter bank $u_{p,m}^k$ corresponding to the identical-bit streams are combined together using MRC, the soft output of MRC Z_u^k is compared to a suitable threshold value S to decide whether it's tentatively decision $\hat{b}_u^k = \text{sgn}(Z_u^k)$ is reliable or not, the output of the threshold comparator \tilde{a}_u^k can be written as [12]

$$\tilde{a}_u^k = \begin{cases} 1 & Z_u^k \geq S, \\ 0 & -S \leq Z_u^k \leq S, \\ -1 & Z_u^k \leq -S, \end{cases} \quad (7)$$

If $|\tilde{a}_u^k| = 1$, \hat{b}_u^k is decided to be reliable otherwise, \hat{b}_u^k is decided to be unreliable. The reliable signals are directly detected, while the unreliable signals are further processed with APIC scheme to get more re-estimate for them. In order to further illustrate this procedure let us assume that without loss of generality users $k=1,2,3,\dots,l$ are reliable,

i.e., $|Z_{u,v}^k| \geq S$ for, $1 \leq k \leq l$ while the other users $k=l+1,\dots,K$ are unreliable, also the user ii is considered unreliable. The reconstructed signal of the k^{th} user, uv^{th} subcarrier, and n^{th} chip is given by

$$\hat{I}_{uv}^{(k)}(n) = \sqrt{\frac{P}{2M}} g_{uv}^{(k)} \cos(\varphi_{uv}^{(k)}) \hat{b}_u^{(k)} c_k(n). \quad (8)$$

The sum of all reconstructed reliable signals $k=1,2,3,\dots,l$ is subtracted from $r_{uv}(n)$ to get $r'_{uv}(n)$ which will be used as a reference signal to determine suboptimum weight for each unreliable signal. After subtracting the reconstructed reliable signals, APIC scheme will be applied as follows, the reconstructed signals of unreliable users are multiplied by their corresponding adaptive weights $w_{uv}^{(k)}(n)$ and summed together to produce an estimate $\hat{r}'_{uv}(n)$ of the reference signal $r'_{uv}(n)$, which can be expressed as

$$\hat{r}'_{uv}(n) = \sum_{k=l+1}^K \hat{I}_{uv}^{(k)}(n) w_{uv}^{(k)}(n). \quad 0 \leq n \leq N-1 \quad (9)$$

The difference between $r'_{uv}(n)$ and $\hat{r}'_{uv}(n)$ constitute the MAI estimation error for unreliable signals, based on this error, a cost function of the adaptive algorithm can be defined as [6]

$$\varepsilon_{uv} = E[e_{uv}(n)^2] = E[r'_{uv}(n) - \hat{r}'_{uv}(n)]^2,$$

where $E[\cdot]$ is the statistical expectation operator and $e_{uv}(n) = r'_{uv}(n) - \hat{r}'_{uv}(n)$ is the error of the MAI estimation. In order to minimize the cost function, the weights $w_{uv}^{(k)}(n)$ are updated at the chip rate according to the Normalized LMS (NLMS) algorithm [6]

$$w_{uv}^{(k)}(n+1) = w_{uv}^{(k)}(n) + \frac{\mu \cdot \hat{I}_{uv}^{(k)}}{\sum_{k=l+1}^K [\hat{I}_{uv}^{(k)}]^2} [e_{uv}(n)]^*, \quad k \in [l+1:K],$$

where μ denotes the step-size, and initial value of weight

$w_{uv}^{(k)}(0)$ of value 0 or 1.

At the end of one transmission interval (bit) the determined weight $w_{uv}^{(k)}(N-1)$ is used with the next stage (PIC) to obtain final decision for the unreliable signals. At PIC stage, suboptimal weights $w_{uv}^{(k)}(N-1)$ are used to weight the input signal $\hat{I}_{uv}^{(k)}(n)$ over the entire transmission interval (bit).

Subtracting the weighted MAI, the "cleaner" signal for the user ii is given by

$$x_{uv}^{(ii)}(n) = r_{uv}'(n) - \sum_{\substack{k=1 \\ k \neq ii}}^K \hat{v}_{uv}^{(k)}(n), \quad (10)$$

where $\hat{v}_{uv}^{(k)}(n)$ is given by

$$\hat{v}_{uv}^{(k)}(n) = \hat{I}_{uv}^{(k)}(n) w_{uv}^{(k)}(N-1), \quad \text{for } k \in [l+1:K].$$

The signal $x_{uv}^{(ii)}$ is then passed to the matched filter bank and the M outputs of matched filter bank are combined via MRC. The final decision for the unreliable signals is obtained according to

$$\tilde{b}_u^{(ii)} = \text{sgn} \left\{ \Re \left[\sum_{n=0}^{N-1} \sum_{m=1}^M x_{uv}^{(ii)}(n) c^{(ii)}(n) g_{uv}^{(ii)} \right] \right\}. \quad (11)$$

After performing SA-PIC for unreliable signals, the final decision for all users are obtained as

$$\hat{b}_u = \sum_{k=1}^l \hat{b}_u^{(k)} + \sum_{k=l+1}^K \tilde{b}_u^{(k)},$$

Where the first term represents the estimated data from the first stage (MF), while the second term represents the re-estimated data after APIC.

IV. PERFORMANCE ANALYSIS OF MC DS-CDMA WITH SA-PIC

This section deals with the performance of the MC DS-CDMA system with the SA-PIC scheme. Owing to the difficulties of find an exact closed form expression for the bit error probability of the system [12], [13], an upper bound for the SA-PIC scheme is introduced instead. The upper bound for the probability of error conditioned on the instantaneous SNR γ is obtained analytically, and then the average probability of error is calculated numerically.

According to [13], for the receiver scheme under study, the total erroneous decision when its happened is based on a reliable decision variable with probability of error $P_{\epsilon_{re}}$, and unreliable decision variable with probability of error $P_{\epsilon_{un}}$, then the upper bound (union bound) for conditional probability of error can be expressed as [13],

$$\begin{aligned} P[e|\gamma] &\leq P_{\epsilon_{re}}(\gamma) + P_{\epsilon_{un}}(\gamma) \\ &\leq Q \left(\frac{S + E[\tilde{Z}]}{\sqrt{\text{Var}[\tilde{Z}]}} \right) + \sum_{l=0}^{K-1} Q \left(\frac{E[\tilde{Z}]}{\sqrt{\text{Var}[\tilde{Z}(l)]}} \right) \binom{K-l}{l} \\ &\quad \times \left[Q \left(\frac{E[\tilde{Z}] - S}{\sqrt{\text{Var}[\tilde{Z}]}} \right) - Q \left(\frac{E[\tilde{Z}] + S}{\sqrt{\text{Var}[\tilde{Z}]}} \right) \right]^{K-l-1} \\ &\quad \times \left[1 - Q \left(\frac{E[\tilde{Z}] - S}{\sqrt{\text{Var}[\tilde{Z}]}} \right) + Q \left(\frac{E[\tilde{Z}] + S}{\sqrt{\text{Var}[\tilde{Z}]}} \right) \right]^l. \end{aligned} \quad (12)$$

In (12) the first term represents the condition probability of error induced by the reliable signals, where S is the threshold value. From (5), $E[\tilde{Z}]$ is given by $(\sqrt{P/(2M)})\gamma$, while the variance $\text{Var}[\tilde{Z}] = \text{Var}[I_{MAI}] + \sigma_n^2$ can be written as

$$\sum_{k=1}^L \frac{P}{4MN} \gamma + \frac{N}{4} \gamma, \quad \text{where } \gamma = \sum_{m=1}^M [g_{uv}]^2, \quad \text{assuming that the channel is normalized with } E[(\alpha_{uv}^{(ii)})^2] = 1.$$

The second term in (12) represents the conditioned probability of error comes from the unreliable signals. The first part of this

term $Q \left(\frac{E[\tilde{Z}]}{\sqrt{\text{Var}[\tilde{Z}(l)]}} \right)$ is evaluated for SA-PIC receiver as

follows. The reference signal $r_{uv}(n)$ can be written as

$$\begin{aligned} r_{uv}(n) &= \sum_{k=1}^l v_{uv}^{(k)}(n) + \sum_{k=l+1}^K v_{uv}^{(k)}(n) + \eta(n) \\ &= \sum_{k=1}^l v_{uv}^{(k)}(n) + r_{uv}'(n), \end{aligned}$$

where $\sum_{k=1}^l v_{uv}^{(k)}(n)$ represents the reliable component of $r_{uv}(n)$,

$\sum_{k=l+1}^K v_{uv}^{(k)}(n)$ is the unreliable component, and $\eta(n)$ is the noise

term. The new reference signal after subtracting the reconstructed reliable signals, $r_{uv}'(n)$ can be written as,

$$r_{uv}'(n) = \sum_{k=l+1}^K v_{uv}^{(k)}(n) + \eta(n). \quad (13)$$

From (10), $r_{uv}'(n)$ can be also expressed in other form as

$$r_{uv}'(n) = \Delta \hat{r}_{uv}'(n) + \sum_{k=l+1}^K \hat{v}_{uv}^{(k)}(n). \quad (14)$$

From (13) and (14), $\Delta r_{uv}'(n)$ can be written as

$$\begin{aligned} \Delta r_{uv}'(n) &= \sum_{k=l+1}^K [v_{uv}^{(k)}(n) - \hat{v}_{uv}^{(k)}(n)] + \eta(n) \\ &= \sum_{k=l+1}^K \Delta v_{uv}^{(k)}(n) + \eta(n). \end{aligned} \quad (15)$$

The he soft output of PIC block for user ii can be defined as

$$x_{uv}^{ii}(n) = r_{uv}'(n) - \sum_{k=l+1}^K \hat{v}_{uv}^{(k)}(n) + \hat{v}_{uv}^{(ii)}(n), \quad (16)$$

from (14), (15), and (16), $x_{uv}^{ii}(n)$ can be expressed as,

$$x_{uv}^{ii}(n) = \Delta r_{uv}'(n) - \Delta v_{uv}^{(ii)}(n) + v_{uv}^{(ii)}(n).$$

The decision variable for APIC $\tilde{z}_u^{(ii)}$ after MF and MRC, is

$$\begin{aligned} \tilde{z}_u^{(ii)} &= \Re \left\{ \sum_{v=1}^M \sum_{n=0}^{N-1} x_{uv}^{ii}(n) c(n)^{ii} [\xi_{uv}^{(ii)}]^* \right\} \\ &= \sum_{n=0}^{N-1} v_{uv}^{(ii)}(n) c(n)^{ii} \sum_{v=1}^M [\xi_{uv}^{(ii)}]^* \\ &\quad + \sum_{n=0}^{N-1} [\Delta r_{uv}'(n) - \Delta v_{uv}^{(ii)}(n)] c^{ii} \sum_{v=1}^M [\xi_{uv}^{(ii)}]^*. \end{aligned} \quad (17)$$

The first term represents the desired signal, where the second term represents the interference, which is approximated as a zero mean Gaussian random variable. From (14), with the

assumption that $\Delta v_{uv}^{(k)}(n)$ is an i.i.d random variable, then

$$E[(\Delta r_{uv}'(n) - \Delta v_{uv}^{(ii)}(n))^2] = \frac{(K-l)E[(\Delta r_{uv}'(n))^2] + \sigma_\eta^2}{(K-l+1)}, \quad (18)$$

where $E[(\Delta r_{uv}'(n))^2]$ is the mean square error of the MAI and it can be approximated as: (see in Appendix A)

$$E[(\Delta r'_{uv}(n))^2] \approx \left(1 + \frac{\mu(K-1)}{2MN}\right) \times \left\{ \frac{(K-1)[1-(1-2p_{mi}(e))^2]}{2MN} + \sigma_q^2 \right\}. \quad (19)$$

Therefore the variance of the interference term is function of number of reliable signals. And it can be written as

$$Var(I(l)) = \sum_{m=1}^M [g_{uv}^{ii}]^2 \cdot \frac{(K-j).E[(\Delta r'_{uv}(n))^2] + \sigma_q^2}{2(K-j+1)}. \quad (20)$$

The mean of the decision variable $\tilde{z}_u^{(ii)}$ is identical with the

mean of the decision variable \hat{Z} , using (20) $Q\left(\frac{E[\tilde{Z}]}{\sqrt{Var[\tilde{Z}(l)]}}\right)$

can be calculated easily. The final upper bound of BER for the SA-PIC scheme can be calculated by averaging with respect to γ

$$P[e] \leq \int_0^{\infty} P[e|\gamma] p(\gamma) d\gamma,$$

where $p(\gamma)$ is the probability density function of γ , which for Rayleigh fading channel can be written as [18]

$$P[\gamma] = \frac{1}{(M-1)!} \gamma^{M-1} e^{-\gamma}.$$

V. NUMERICAL RESULTS

In this section computer simulations are provided to validate the theoretical development. The MC DS-CDMA system described in Section 2 is used in simulation. A random binary sequences of processing gain $N=31$ are used for data spreading. The diversity order M is set = 2. The threshold value S is normalized to the mean amplitude value of the decision variable Z_u . The total transmitted power is the same irrespective of the number of subcarriers, and a perfect power control system is assumed. The implementation complexity of the proposed scheme is discussed at the end of this Section. Fig.3. shows that as S equals to zero, which means that all input signals are considered reliable, the performance of SA-PIC is similar to the performance of MF stage. However when S is relatively high ($=5$) all input signals are considered unreliable. Consequently the performance of the SA-PIC is similar to the performance of APIC. Now, the tight of the upper bound of BER derived in section 4 is tested for different threshold values S . The upper bound of BER in addition to the simulation results are plotted in Fig.4. The results show that there is a good agreement between upper bound form and

simulation results especially for high value of S .

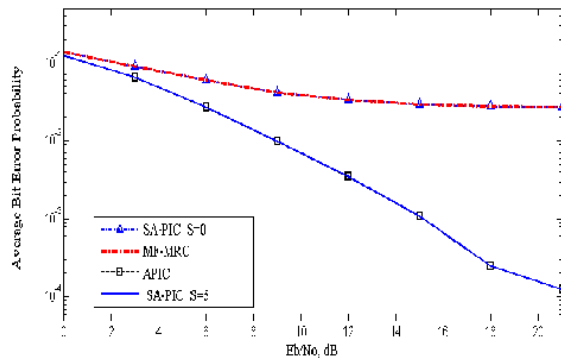

Fig.3. Bit error probability of APIC, MF-MRC, and SA-PIC for $S=0.0$ and $S=5.0$

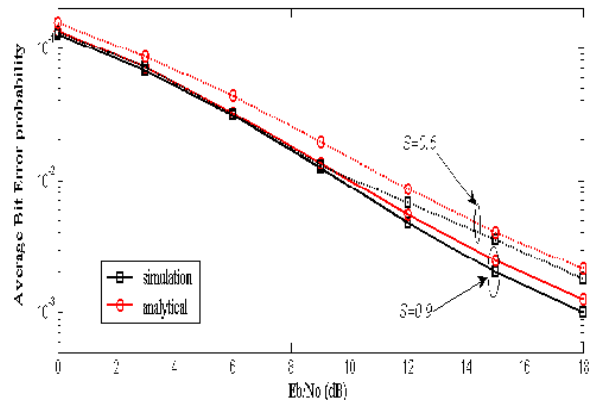

Fig.4 Analytical (upper bound) and simulation results of SA-PIC for $K=26$ and different values of S

Fig.5 and Fig.6 show the dependence of BER on the value of S for different values of E_b/N_0 and for number of users 16, and 26 respectively. The figures show that at $S=0.4$, low BER can be obtained. It is also seen that increasing the value of S above 0.4 does not add significant performance gain but increases the complexity of the system. This result coincides with the conditional probability of error of the system given by (11). Fig.7. illustrates the performance of the SA-PIC for $S=0.4$. The figure shows that the performance of SA-PIC is the same as the performance of APIC for different number of users

TABLE I
NUMBER OF COMPLEX OPERATIONS REQUIRED PER BIT.

Operation	SA-PIC		APIC	
	multiplication	addition	multiplication	addition
Comparator and subtract reliable signals	MK	L	-	-
Weights calculations	$NM[3(K-L)+2]$	$NM[3(K-L)-1]$	$NM[3K+2]$	$NM[3K-1]$
Interference cancellation	$NM(K-L)[K-L-1]$	$NM(K-L)$	$NMK(K-1)$	NMK
total	$NM[(K-L)(K-L+2)+2]+MK$	$NM[4(K-L)-3]+L$	$NM[K(K-1)+3K+2]$	$4NMK-NM$

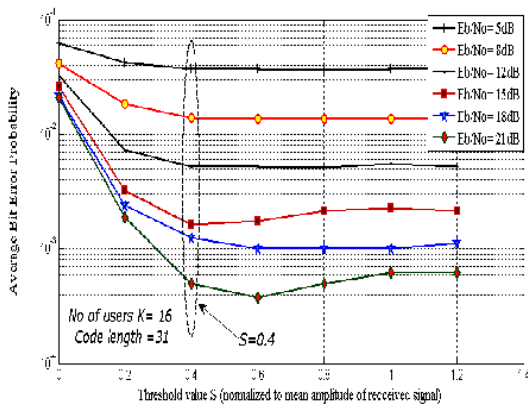

Fig. 5 Dependence of average bit error probability of SA-PIC on the threshold value S (relative to mean amplitude value) for different E_b/N_o values, $K=16$

$K=10, 16, 26$. The benefit of using SA-PIC is that it has lower complexity than APIC as will indicated at the end of this section.

Fig.8. depicts the performance comparison of SA-PIC, MF, CPIC, and APIC schemes. It is clear that SA-PIC scheme outperforms both MF and CPIC schemes, while its performance almost the same as APIC scheme. However, the SA-PIC algorithm allows the implementation complexity to be notably reduced with respect to APIC scheme as discussed at the end of this section. The SA-PIC scheme implementation complexity in terms of complex-valued operations is evaluated and compared with APIC under the same parameters. Table 1 shows the number of complex multiplication and addition per bit required to perform SA-PIC, and APIC schemes. The notations in the table are as follows. K denotes the number of users, M diversity order, N spreading gain, and L number of reliable signals. In Table 2, a numerical values of the number of multiplications and additions required by both schemes at

TABLE II
NUMERICAL VALUES OF COMPLEX OPERATIONS REQUIRED PER BIT

$\frac{E_b}{N_o}$ dB	SA-PIC ($S=0.4$)		APIC	
	multiplication	addition	multiplication	addition
0	1002	540	7564	2418
6	841	441		
12	757	392		
18	716	367		

different E_b/N_o are calculated using the following parameters $K=10, M=2, N=31, S=0.4$, and the average value of L is estimated by simulation. Note that the complexity of the APIC scheme does not depend on E_b/N_o while in SA-PIC scheme, the complexity depends on E_b/N_o because the value of L depends on E_b/N_o . Table 2 shows that for practical values of E_b/N_o , the complexity of SA-PIC system is less than that one of the APIC scheme.

VI. CONCLUSION

SA-PIC scheme with synchronous MC DS-CDMA system over Rayleigh fading channels has been studied. The performance of the scheme is driven analytically and through simulation. It has been shown there is a good agreement between them. Its performance gives same results as APIC. The implementation complexity of this receiver in terms of number of cancellation to be performed was lower than of the APIC scheme.

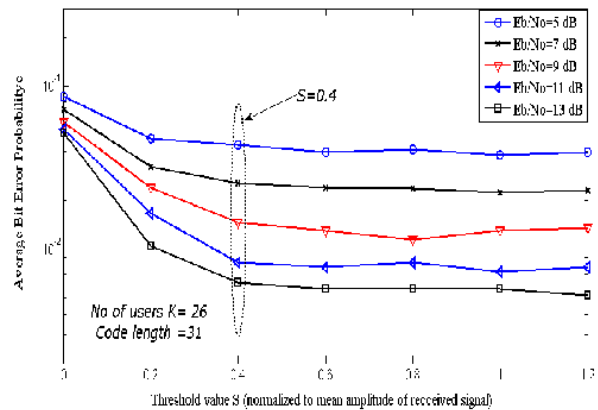

Fig.6. Dependence of average bit error probability of SA-PIC on the threshold value S for different E_b/N_o values, number of users $K=26$

APPENDIX

Using the same method used in [17], assuming the number of reliable signals is l , the input signal to the normalized LMS algorithm can be written as $\mathbf{I}_{uv}(n) = [\hat{I}_{uv}^{(l+1)}(n), \hat{I}_{uv}^{(l+2)}(n), \dots, \hat{I}_{uv}^{(K)}(n)]^T$, the autocorrelation matrix of the input signals is defined as

$\mathbf{R}_{uv} = E[\mathbf{I}_{uv}(n)\mathbf{I}_{uv}^T(n)]_{(K-l) \times (K-l)}$. Assuming *i.i.d* source data with $E[b_{uv}^k b_{uv}^l] = \delta_{k,l}$, and the channel is statistically identical for all users. The normalized autocorrelation matrix \mathbf{R}_w can be written as $\mathbf{R}_w = \frac{1}{2MN} \mathbf{I}_{(K-l)}$ where $\mathbf{I}_{(K-l)}$ is a unit matrix. The inverse of the matrix \mathbf{R}_w can be written as $\mathbf{R}_w^{-1} = 2MM_{(K-l)}$. The reference signal for the normalized LMS algorithm is given in (9), hence the cross-correlation vector between the input signal, and the reference signal is given by

$\mathbf{P}_{uv} = E[\mathbf{I}_{uv}(n)r'_{uv}(n)]$. The MMSE is expressed as [17].

$$\epsilon_{\min} = E[r'_{uv}(n)]^2 - \mathbf{P}^H \mathbf{R}^{-1} \mathbf{P} \tag{1}$$

Under assumption of *i.i.d* source data, the variance of the reference signal according to (12) is given by

$$E[r'_{uv}(n)]^2 = E \left[\sum_{\substack{k=1 \\ k \neq i}}^K v_{uv}^{(k)}(n) + \eta(n) \right]^2 = \frac{(K-l)}{2MN} + \sigma_{\eta}^2 \tag{2}$$

where $\sigma_{\eta}^2 = \text{var}(\eta(n)) = N_o / 2$. from (6), (8) and (12), the i th component of cross-correlation vector \mathbf{P}_{uv} can be written as

$$\frac{P}{2MN} E[b_u^{(k)} \hat{b}_u^{(k)}] = \frac{1-2p_{mi}(e)}{2MN} \tag{3}$$

Hence the cross-correlation vector is given by

$$\mathbf{P} = \frac{1-2p_{mi}(e)}{2MN} \underbrace{[1 \ 1 \ 1 \ \dots \ 1]}_{K-l}^T \tag{3}$$

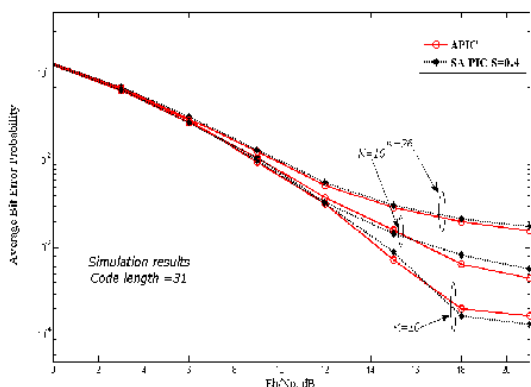

Fig.7. Bit error probability of APIC, SA-PIC for $S=0.4$, $K=10, 16$, and 26 .

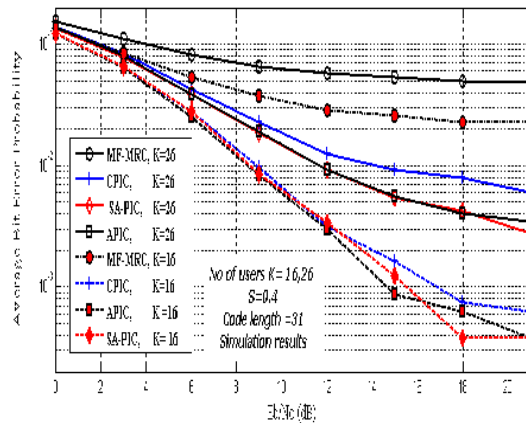

Fig.8 Comparisons of Bit error probability for SA-PIC, CPIC, and APIC schemes for $S=0.4$, and $K=16, 26$ users

where $p_{mi}(e)$ is the BER of MF-MRC stage. The MMSE in (A.1) can be written as

$$\epsilon_{\min}(l) = \frac{(K-l)[1-(1-2p_{mi}(e))^2]}{2MN} + \sigma_{\eta}^2 \tag{4}$$

The mean square error (MSE) of the estimation can be represented as two terms[21], $MSE = \epsilon_{\min} + \epsilon_{\text{excess}}$,

where, $\epsilon_{\text{excess}} = \lambda \cdot \epsilon_{\min}$, assuming that the step size is properly selected, then misadjustment of the LMS is less than 10% [21], hence the mean square error of the MAI can be written as

$$MSE = \left(1 + \frac{\mu(K-l)}{2MN} \right) \frac{(K-l)[1-(1-2p_{mi}(e))^2]}{2MN} + \sigma_{\eta}^2$$

REFERENCES

- [1] M. L. Honig and H. V. Poor, "Adaptive interference suppression," in *Wireless Communications: Signal Processing Perspectives*, pp. 64–128, Prentice-Hall, Upper Saddle River, NJ, USA, 1998.
- [2] S. J. Chern, C. Y. Chang, and T. Y. Liao, "Adaptive multiuser interference cancellation with robust constrained IQRD-RLS algorithm for MC-CDMA system," in *Proceedings of IEEE international Symposium on Intelligent Signal Processing and Communication Systems*, pp. 242–246, Nashville, Tenn, USA, November 2001.
- [3] L. Fang and L. B. Milstein, "Successive interference cancellation in multicarrier DS/CDMA," *IEEE Transactions on Communications*, vol. 48, no. 9, pp. 1530–1540, 2000.
- [4] J. G. Andrews and T. H. Y. Meng, "Performance of multicarrier CDMA with successive interference cancellation in a multipath fading channel," *IEEE Transactions on Communications*, vol. 52, no. 5, pp. 811–822, 2004.
- [5] Divsalar, M. K. Simon, and D. Raphaeli, "Improved parallel interference cancellation for CDMA," *IEEE Transactions on Communications*, vol. 46, no. 2, pp. 258–268, 1998.
- [6] S.H. Han, J.H. Lee, Adaptive multi-stage parallel interference cancellation receiver for multi-rate DS-CDMA system, *IEICE Trans. Commun. E 87-B (8) (2004) 2401–2405*.
- [7] S.H. Han and J.H. Lee, "Performance of multi-rate DS-CDMA system with multi-stage partial parallel interference cancellation," *Proc. IEEE VTC 2000-Spring*, pp.765-769, Tokyo Japan, May 2000.

- [8] S.R. Kim, et al., Adaptive weighted parallel interference cancellation for CDMA systems, *Electron. Lett.* 34 (22) (1998) 2085–2086.
- [9] G. Xue, j. Weng, T. Le-Ngoc, S. Tahar, Adaptive multistage parallel interference cancellation for CDMA, *IEEE j. Select. Areas Comm.* 17 (10) (1999) 1815-1827.
- [10] S.H. Han, J.H. Lee, Adaptive multi-stage parallel interference cancellation receiver for multi-rate DS-CDMA system, *IEICE Trans. Commun. E* 87-B (8) (2004) 2401–2405.
- [11] R. Fantacci. "Proposal of an Interference Cancellation Receiver with low complexity for DS-CDMA for mobile communication systems," *IEEE Transactions on Vehicular Technology*, no. 4, 1039-1046, 1999.
- [12] J. Baea, I. Songb, D. H. Wonb, "A selective and adaptive interference cancellation scheme for code division multiple access systems" *Signal Processing* 83 (2003) 259 – 273.
- [13] R. Fantacci, D. Marabissi, S. Morosi, "Performance Analysis and Optimization of a Space-Time Selective PIC for CDMA Systems," *IEEE Transactions on Wireless Communications*, Vol.3, No. 2, 359-366, March 2004.
- [14] H.Wang, K. W. Ang, K.Yen, Y. H. Chew, "An adaptive PIC receiver with diversity combining for MC-DS-CDMA system," *Vehicular Technology Conference*, 2003. VTC 2003-Fall. 2003 IEEE 58th.
- [15] Lin Fang Milstein, L.B. "Performance of successive interference cancellation for a multicarrier DS/ CDMA system." *Military Communications Conference Proceedings*, 1999. MILCOM 1999.
- [16] Manohar, S. Tikiya, V. Annavajjala, R. Chockalingam, A. "BER analysis of weighted interference cancellation in multicarrier DS-CDMA systems." *Wireless Communications and Networking Conference*, 2006. WCNC 2006.
- [17] H.Wang, K. Yen, K.W. Ang, and Y. H. Chew, "Design and performance analysis of an adaptive receiver for multicarrier DS-CDMA," *EURASIP Journal on Wireless Communications and Networking*, vol. 2007 , Issue 2 January 2007.
- [18] Hanzo, L., Yang, L. L., Kuan, E. L. and Yen, K. "Single-and Multi-carrier DS-CDMA: Multi-User Detection, Space-Time Spreading, Synchronisation, Standards and Networking," (2003), John Wiley & Sons.
- [19] S. Hara and R. Prasad, "Overview of multicarrier CDMA," *IEEE Communications Magazine*, vol. 35, no. 12, pp. 126-133, 1997
- [20] A. Kaiware and M.Nakagawa, "Microcellular CDMA system with a linear multiuser interference canceller," *IEEE journal on Selected Areas in Communications*, vol. 12, no. 4, pp. 605-611, 1994.
- [21] Paulo S. R. Diniz, "Adaptive Filtering Algorithms and Practical Implementation, 3rd ed., Springer, New York, 2008.