

Optimal DG Placement in Distribution systems Using Cost/Worth Analysis

M Ahmadigorji, A. Abbaspour, A Rajabi-Ghahnavieh, M. Fotuhi- Firuzabad, *IEEE Senior member*

Abstract— DG application has received increasing attention during recent years. The impact of DG on various aspects of distribution system operation, such as reliability and energy loss, depend highly on DG location in distribution feeder. Optimal DG placement is an important subject which has not been fully discussed yet.

This paper presents an optimization method to determine optimal DG placement, based on a cost/worth analysis approach. This method considers technical and economical factors such as energy loss, load point reliability indices and DG costs, and particularly, portability of DG. The proposed method is applied to a test system and the impacts of different parameters such as load growth rate and load forecast uncertainty (LFU) on optimum DG location are studied.

Index Terms—Distributed generation, optimal placement, cost/worth analysis, customer interruption cost, Dynamic programming

I. INTRODUCTION

Distributed generation (DG) is defined as small generation units installed in distribution systems. It is predicted that DG would have a share of about 20% of new generating units being onlined [1]. Even though the concept of DG application in distribution system is not new, there is an increasing trend towards DG application in power systems. Environmental concerns, economical consideration, technological advancements and power system deregulation are known as accelerating factors for DG application. DG application results in positive and negative side effects for both utility and customers [2]. Generally, DG impacts on distribution system depend on several factors such as DG location, technology and capacity as well as the mode of DG operation with network. Application of DG in distribution networks can lead to considerable reliability enhancement, loss reduction and power cost saving. In contrast, power quality issue, islanding operation and voltage control problems are among troublesome impacts of DG application.

The impact of DG on system operation depends highly on DG location in the distribution system such that installing DG on

improper locations would lead to increase in energy loss and loading of distribution feeders. For this reason, an optimization method must be used to find optimal DG location considering the costs and benefits of DG application to the customers and the utility. Optimal DG placement is a multi-variable optimization problem with different constraints on DG and distribution system operation [3]. In [4], optimal DG location is obtained considering economic and operational limits of DG and distribution system. Optimal DG placement is accomplished in [5] to maximize DG application benefit and minimize the costs for both utility and customers. A loss-minimization approach is used in [6] to find optimal DG location.

These works does not consider all aspects of DG location while finding the optimum location. Particularly, the portability of DG is not incorporated in the existing methods and it was assumed that the DG location would not change during the study period. However, one DG advantage over central generating units is that many DG are portable and can be displaced when required.

In this paper, a method is developed to find the optimum DG location for each year of the study period, based on a cost/worth analysis approach. The method considers the portability of DG and the optimum DG location of each year is found which might be different for those obtained for other years. It is also assumed that DG is owned and operated by the utility and the cost and benefit of DG application to both utility and customers are taken into account. The proposed method is then applied to a distribution test system to find optimal DG location for each year of a 10-year study period. The impact of load growth rate on optimal locations is studied. The method is then extended to incorporate load forecast uncertainty (LFU) in finding optimal DG location and its impact is studied.

II. PROPOSED METHOD

Optimal DG placement aimed to find the optimal DG location in order to maximize or minimize a specific objective function with respects to considered variables and constraints. An important approach is to incorporate the cost and benefit of DG application in the objective function. The problem constraints usually include various technical and operational

The authors are with the centre of excellence in power system control and management, Department of Electrical Engineering, Sharif University of technology, Tehran, Iran.

(email: ahmadigorji@ee.sharif.edu)

(email: abbaspour@sharif.edu)

(email: a_rajabi@ee.sharif.edu)

(email: fotuhi@sharif.edu)

limits of DG and system operation such as DG portability, bus voltage level and feeder loading.

Here, a cost/worth approach is explained for placement of a utility-owned DG in distribution system. The objective function is the benefit to cost ratio of DG application in which DG cost and benefit to both utility and customers are considered. DG cost is composed of the initial investment cost, operation and maintenance cost and DG displacement cost. DG benefit is composed of loss reduction revenue, power purchase saving and reduction of customer interruption cost due to application of DG.

The displacement of DG can take place at the beginning of each year. However, it is assumed that the displacement of DG from its current location to another location is possible if and only if DG has been already installed in its current location for minimum MRT years. The value of MRT depends on DG technology.

The application of DG (i) in the candidate point (k) at year (j) is determined by the binary variable introduced in (1).

$$A_{ijk} = \begin{cases} 1 & \text{if DG(i) locates at place(k) in year(j)} \\ 0 & \text{otherwise} \end{cases} \quad (1)$$

The objective function is defined as in (2).

$$\text{Max BCR} = \frac{\text{Benefit}_{DG}}{\text{Cost}_{DG}} \quad (2)$$

Where BCR refers to benefit to Cost Ratio, Benefit_{DG} and Cost_{DG} refer to total benefits and total costs of DG application, respectively.

$$\text{Benefit}_{DG} = \sum_{k=1}^{N_{DG}} \sum_{j=1}^{N_{year}} \sum_{k=1}^{N_{loc}} (\Delta CIC_{ijk} + LRR_{ijk} + RPS_{ijk}) \times A_{ijk} \quad (3)$$

$$\text{Cost}_{DG} = \sum_{i=1}^{N_{DG}} IC_i + \sum_{i=1}^{N_{DG}} \sum_{j=1}^{N_{year}} \sum_{k=1}^{N_{loc}} (OP_{ij} + MC_{ij} + TC_{ij}) \times A_{ijk} \quad (4)$$

A. DG Benefits Calculation

DG Benefits for each year (8760 hrs) is composed of Loss Reduction Revenue (LRR) and Power Purchase Saving (PPS) as calculated in (5), (6). PPS, particularly, represents the utility saving due to reduction in electric power that must be purchased from electricity market to supply the customers.

$$LRR_{ijk} = \sum_{i=1}^{N_{DG}} \sum_{j=1}^{N_{year}} \sum_{k=1}^{N_{loc}} \Delta Loss_{ijk} \times (1 + IR) \times (EP_j) \quad (5)$$

$$PPS_{ij} = \sum_{i=1}^{N_{DG}} (ADG_i \times EP_j) \quad (6)$$

Where,

EP_j : Wholesale Electricity price in year (j) (c/kwh)

IR : Interest rate (%)

ADG_i : Annual DG generation of DG (i) (kwh)

N_{year} : Number of years in the study period

N_{loc} : Number of candidate locations for DG installation

N_{DG} : Number of DGs

Annual DG generation is calculated considering DG capacity and maintenance and failure outages as presented in section III.

Considering inflation rate IF , the value of EP for year (j) can be calculated using (7):

$$EP_j = EP_0 \times (1 + IF)^{j-1} \quad (7)$$

Where,

EP_j = EP in year (j)

EP_0 = Initial value of EP

Since the DG can't deliver energy to the system during the maintenance outage of D_{main} days, assuming simultaneous and equal maintenance outage for all DGs, $\Delta Loss_{ijk}$ and ΔCIC_{ijk} values are obtained as in (8) and (9):

$$\Delta CIC_{ijk} = \left(\frac{365 - D_{main}}{365} \right) (CIC_{old} - CIC_{ijk}) + \left(\frac{D_{main}}{365} \right) (CIC_{old}) \quad (8)$$

$$\Delta Loss_{ijk} = \left(\frac{365 - D_{main}}{365} \right) (Loss_{old} - Loss_{ijk}) + \left(\frac{D_{main}}{365} \right) (Loss_{old}) \quad (9)$$

Where,

$Loss_{old}$: Annual energy loss, without DG application (kwh)

$Loss_{ijk}$: Annual energy loss when DG applied (kwh)

CIC_{old} : Annual Customer interruption cost, without DG application (\$)

CIC_{ijk} : Annual Customer interruption cost, DG applied (\$)

B. DG costs calculation

Cost_{DG} is composed of following parts:

IC_i : Initial cost of DG (i) (\$)

MC_{ij} : Maintenance cost of DG (i) in year (j) (\$)

OC_{ij} : Operation cost of DG (i) in year (j) (\$)

TC_{ij} : Transition cost of DG (i) at the beginning of year (j) (\$)

Initial cost (IC) includes procurement and installation costs. Maintenance cost (MC) consists of repair cost (RC) and lost DG revenue during maintenance outage (MEC), as in (10) and (11):

$$MC_{ij} = HC_{ij} + MEC_{ij} \quad (10)$$

$$MEC_{ij} = h_{main} \times EP_j \times (1 + IR) \times G_{i,rated} \quad (11)$$

Where, h_{main} is the maintenance duration, in hour, and, $G_{i,rated}$ is the rated power of DG (i). MC is independent of DG location and is calculated for different years according to inflation rate (IF), as in (12):

$$MC_{ij} = MC_{i0} \times (1 + IF)^{j-1} \quad (12)$$

Where,

MC_{i0} = Initial value of MC

MC_{ij} = MC of DG (i) in year (j)

Considering the Annual DG (i) Generation (ADG_i), operation cost (OC) is equivalent to fuel cost and is calculated using (13):

$$OC_{ij} = ADG_i \times FC_j \times FE \quad (13)$$

Where,

OC_{ij} = operation cost of DG (i) in year (j) (\$)

FC_j = Fuel cost in year (j) (\$ / Mbtu)

FE = Thermal efficiency (Mbtu/ Kwhr)

TC_{ij} is composed of two parts of $DC_{ikk'}$ and LDG. $DC_{ikk'}$ represents the cost of DG displacement from point K at the end of year (j-1) to point K' at the beginning of year j, as obtained in (14). $DC_{ikk'}$ includes the costs of DG dismantling and re-installation. Dismantling and re-installation costs are considered to be equal to 30% and 20% of DG initial cost, respectively. LDG is the lost DG revenue during displacement and is calculated using (15).

$$TC_{ij} = \sum_{k=1}^{N_{loc}} \sum_{k'=1}^{N_{loc}} ((A_{i,j-1,k} \times A_{ijk'}) \times (DC_{ikk'} + LDG_{ij})) \quad (14)$$

$$LDG_{ij} = (h_{trans} \times G_{i,rated} \times EP_j \times (1 + IR)) \quad (15)$$

Where, h_{trans} is the DG displacement duration, in hour, which is considered the same for all DGs and all displacements.

C. Optimization Constraints

The objective function (2) is to be solved subjected to the following constraints. Although all DGs are to be applied during the study period, one and only one DG can be placed at each point, so:

$$\sum_{k=1}^N A_{ijk} = 1 \quad i = 1, \dots, N_{DG} \quad (16)$$

$$j = 1, 2, 3, \dots, N_{year}$$

Optimization problem includes other constraints such as MRT and operational constraints. As operational constraints, the voltage of all buses must be between 0.95 to 1.05 pu and the loading of distribution feeders shouldn't exceed their normal

rating. In case of violation of these limits, corrective action such in form of load shedding or load transfer will be applied to remove the violations.

III. CALCULATION OF VARIABLES AND INDICIES

A. Reliability and Loss Calculation

The System is assumed to have its annual peak load. Considering the load growth rate of a , the peak load associated with each year is calculated using (17):

$$L_{pj} = L_{po} \times (1 + a)^{j-1} \quad (17)$$

Where,

L_{po} = Initial Peak load

L_{pj} = Peak load in year j

Calculation of reliability indices and energy loss is one of the main parts of problem solution. In this paper, Digsilent power system analysis software [7] is used in order to calculate the loss and reliability indices (CIC). Digsilent is a powerful digital simulation and power system calculation package. This software is leading software to accomplish different power system studies and is capable of modeling different types of DG [7].

Loss calculation is carried out using load flow module of Digsilent. For reliability calculation, two modes are available: Monte Carlo simulation and state enumeration [8]. In this paper, Monte Carlo simulation mode is applied for reliability calculation (CIC) considering operational constraints.

B. DG Annual Generation Calculation

To calculate DG generation, it is required to calculate the duration of each state of the three-state DG operation model [8], as shown in Fig. 1.

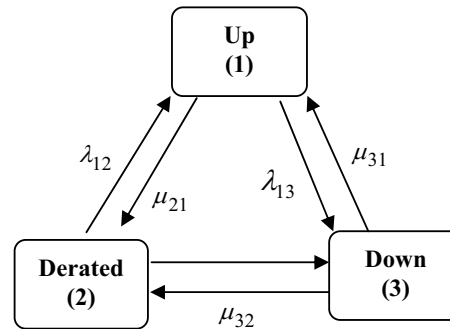

Fig.1. Three-states model for DG

Expected duration of each state is calculated using (18):

$$h_C = P_C \times 8760 \quad (18)$$

Where, h_C is the duration of each is state and P_C is the probability of each state. The Frequency-balanced technique [9] is used to calculate P_C .

$$P_1 (\lambda_{13} + \lambda_{12}) = P_2 \mu_{21} + P_3 \mu_{31} \quad (19)$$

$$P_1 + P_2 + P_3 = 1 \tag{20}$$

Annual DG generation is calculated by (21):

$$ADG = \sum_{C=1}^3 h_C \times G_C \tag{21}$$

Where, G_C is generation capacity in state C.

IV. OPTIMIZATION TECHNIQUE

In this paper, a forward Dynamic Programming (DP) approach is used to solve the optimal DG placement problem. Using this approach, considering inflated rate of cost and benefit in each year and DG portability, all of the possible paths from first year to the 10th year, are searched. At the end, the path with the maximum value of BCR is determined as the optimum solution for DG placement during 10 years.

Both $Benefit_{DG}$ and $Cost_{DG}$ are determined as a matrix with dimension of $N_{state} \times N_{year}$ in which, N_{state} is the total states in each year and N_{year} is the number of years in desired period. Thus, N_{state} can be calculated using (22):

$$N_{state} = N_{loc} \times N_{DG} \tag{22}$$

Therefore, the number of all which must be searched is calculated using (23):

$$N_{path} = N_{state} \times N_{year} \tag{23}$$

If the number of DGs or candidate locations for DG placement increases, the search space and optimization run time increase considerably. The search space can be drastically reduced by adding some restrictions on the searched paths. Fig.2 illustrates the restriction in search space considering $X=5$ and $NP=3$, where X is the total number of states and NP is the allowed number of paths to be searched at each step [10].

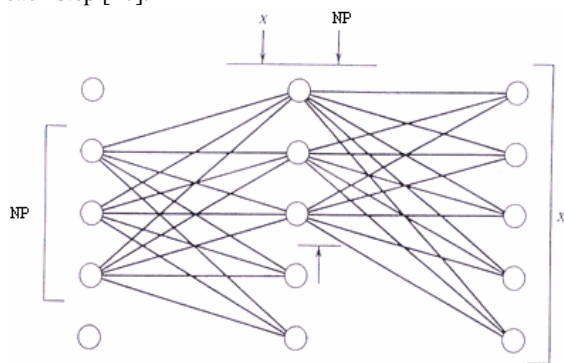

Fig 2. Reduction in search space with $X=5$ and $NP=3$ [10]

IV. METHOD APPLICATION

The proposed method is applied to distribution reliability test system of Digsilent (RTS). Fig.11 demonstrates the single line diagram of this system [7].

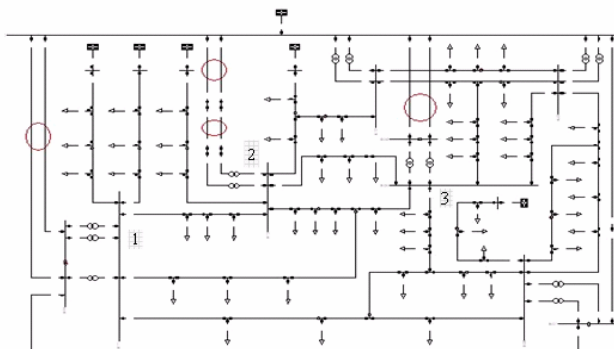

Fig 3. Single line of Distribution test system of Digsilent [7]

This test system is a radial 33/11kV power distribution system including four 33kV and eleven 11kV buses. The system provides the possibility of load transfer in case of contingencies.

DG installation is possible in 11kV buses and the candidate places are shown in Fig3 with numbers of 1, 2, and 3, respectively. One Diesel generator and one Micro turbine are available. DG generation capacity, with respect to Fig 1, is 1.5,1,0 Mw for Diesel and 1, 0.5 and 0 Mw for Micro turbine, respectively. The transition rates presented in [2] and [8] are used for DG operation states are shown in Table 1.

Table 1. Transition rate between DG states

Technology [occ/year]	Diesel	Micro turbine
λ_{12}	36.5	2.9
λ_{13}	0	8.03
λ_{23}	109.5	6.9
μ_{21}	73	91.2
μ_{31}	0	1071.5
μ_{32}	657	62.4

The numerical values of other DG variables are shown in Table 2. Particularly, [11] is used to determine IC and MC of DGs.

Table 2. Numerical value required for optimization

Technology variable	Diesel	Micro turbine
IC (\$)	482000	510000
MC _o (\$)	25000	22000
MRT (years)	2	1
h_{main} (hrs)	48	48
h_{trans} (hrs)	120	120

EP_0 and IR are assumed to be 8.5c/kWh and 5%, respectively.

Based on fuel cost prediction presented in [11], fuel cost in each year is shown in Table 3.

Table 3. Fuel cost during desired period

Year	FC (\$/Mbtu)
1 to 2	2.54
3 to 7	2.61
8 to 10	2.74

$DC_{ikk'}$ for each DG and for the two candidate places are shown in Table 4.

Table 4. $DC_{ikk'}$ of DG displacement between candidate locations (\$)

$DC_{ikk'}$	1-2	1-3	2-3
Diesel	241000	239000	241000
Micro turbine	255000	253000	255000

Also, h_{trans} is considered the same for displacement between each two points of candidate places for both DGs and $DC_{ikk'}$ is considered the same for DG displacement from point (k) to point (k') and visa versa.

A. Study results

Considering number of DGs and candidate points, optimal placement is carried out for a 10-year study period. At first, optimal placement is obtained without any restriction on number of searched paths in the optimization process. Then, a restriction is made on the number of paths that are analyzed during optimization. At each displacement from year ($j-1$) to year (j), only NP paths with higher value of BCR are analyzed and kept for the rest of optimization. This procedure continues until the end year of (10th year).

In this section, optimal placement is carried out with NP=0 and NP=8000. Table.5 shows the optimal placement results for 10 years study period when the load growth rates are assumed to be 2%, 6%, 10%, respectively.

The results obtained show that optimal solution for all load growth rates are equal in the case of NP=0 and NP=8000. However, run times for NP=0 for all load growth is achieved 4.5 hrs, but with respect to NP=8000, this time considerably decreases which is shown in Table 6:

Table 5. Optimal placement results for considered load growth rates

year	DG location			Micro turbine Location		
	a=2%	a=6%	a=10%	a=2%	a=6%	a=10%
1	2	2	2	1	1	1
2	2	2	2	1	1	1
3	2	2	2	1	1	1
4	1	2	2	1	1	1
5	1	2	2	1	1	1
6	1	2	2	1	1	1
7	2	2	2	1	1	1
8	2	2	2	1	1	1
9	2	2	2	2	1	1
10	2	2	2	1	1	1

Table 6. Optimizations run times for associated load growth rate

Load growth (a)	Run time (Sec)
2%	53.48
6%	463.344
10%	626.6

Study results show that, for a=2%, Diesel is displaced 3 times, where, Micro turbine is displaced 4 times. No displacement is observed for the both DGs when a=6%. Therefore, the number of displacement of both DGs during the study period reduces when the load growth rate increases.

In addition, the number of Diesel displacement is less than that of Micro turbine as expected due to higher value of $DC_{ikk'}$ for Diesel, comparing to that of Micro turbine.

Optimum place of the Micro turbine in year 10 is the same for all load growth rates. However, for Diesel unit, in the case of a=2%, optimum place in 10th year is different with the corresponding place for a=6% or 10%.

Table 7 shows the obtained values for BCR , $Benefit_{DG}$, $Cost_{DG}$ and corresponding $Profit_{DG}$ of solution associated with load growth rates.

Table 7. Economical indices of results associated with load growth rates

Load growth rate	BCR	$Cost_{DG}$	$Benefit_{DG}$	$Profit_{DG}$
2%	3.294	10098500	33263700	23165200
6%	3.3438	8357400	27945500	19588100
10%	3.4941	8357400	29202500	20845100

$Profit_{DG}$ is the profit achieved by utility system according to DG application and is calculated using (24):

$$Profit_{DG} = Benefit_{DG} - Cost_{DG} \tag{24}$$

Comparing the results in Tables 7 and 8, it can be seen that by increase of the load growth rate, BCR increases while the benefit and profit firstly decrease and then increase. The DG cost decreases for a=6% and remains unchanged for a=10%. Since there isn't any DG displacement for a=6% and 10%, there isn't any cost associated to DG displacement and, hence, the calculated cost is smaller than that obtained for a=2%.

Fig. 4 illustrates the variation in BCR during 10 years study period for each load growth rate:

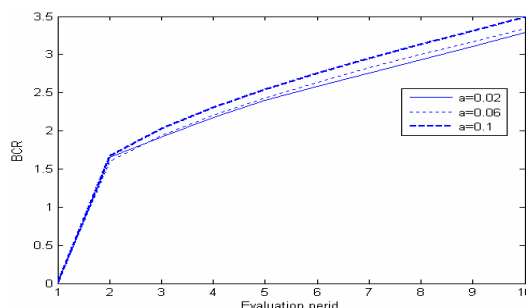

Fig. 4. BCR variation during 10 year

B. Effect of NP on optimal solution

Since NP limits the number of paths searched during optimization, it is probable that the obtained solution wouldn't be the global optimum of the problem. In order to evaluate the impact of NP value on optimal place of DG, the proposed method is applied to the test system for all load growth rates using various NP values such as 1000, 5000,8000,12000. Study results showed that, for a=2%, optimal solution is obtained for NP greater than 8000. However, for a=6% and 10%, the optimal solution is obtained if NP is greater than 5000.

VI. LOAD FORECAST UNCERTAINTY MODELING

It is interesting to incorporate the peak load uncertainty in the optimal DG placement problem. The approach presented in [8] is used to model load forecast uncertainty. In this approach, the system peak load distribution is modeled with a normal distribution function in which the mean value is equal to the forecasted peak load. The distribution is then divided into seven intervals [8] as shown in Fig. 5.

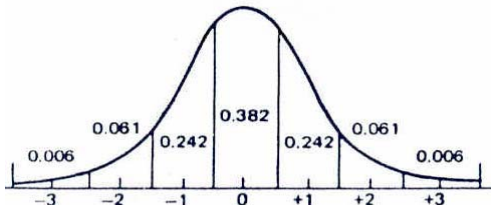

Fig. 5. Normal distribution associated with load forecast uncertainty [8]

In Fig.5, horizontal axis is the interval number. The probability of each interval is also shown in Fig. 5 which is calculated using normal probability function. For each interval, the peak load is equal to the mid-point value of the interval (25).

$$Peak_m = \mu \times (1 + m\sigma) \tag{25}$$

Where,

$Peak_m$ = Peak load for interval m

m= interval number

μ =forecasted peak load for each year (mean value)

σ =standard deviation of peak load uncertainty

The calculation of different component of (2) is performed for each interval, assuming that the system peak load is equal to that obtained for that interval. The results for each interval then are weighted by the corresponding probability of the interval as in (26) to (29).

$$CIC_{old,un} = \sum_{i=1}^7 (P_m \times CIC_{old,m}) \tag{26}$$

$$CIC_{ijk,un} = \sum_{i=1}^7 (P_m \times CIC_{ijk,m}) \tag{27}$$

$$Loss_{old,un} = \sum_{i=1}^7 (P_m \times Loss_{old,m}) \tag{28}$$

$$Loss_{ijk,m} = \sum_{i=1}^7 (P_m \times Loss_{ijk,m}) \tag{29}$$

Where,

$CIC_{old,un}$ = Annual Customer interruption cost before DG application considering LFU

$CIC_{ijk,un}$ = Annual customer interruption cost with DG application, considering LFU

P_m = Probability of interval m

$CIC_{old,m}$ = Customer interruption cost before DG application for interval m

$CIC_{ijk,m}$ = Customer interruption cost with DG application for interval m

$Loss_{old,m}$ = Energy Loss before DG application for interval m

$Loss_{ijk,m}$ = Energy Loss with DG application for interval m

$Loss_{old,un}$ = Annual Energy Loss before DG application considering LFU

$Loss_{ijk,un}$ = Annual Energy Loss with DG application considering LFU

Table 8 shows the optimal solution for all load growth rates with respect to LFU in which, μ is obtained from (17) and $\sigma = 2\%$.

Table 8. Optimal placement results associated with LFU ($\sigma = 2\%$)

year	DG location			Micro turbine Location		
	a=2%	a=6%	a=10%	a=2%	a=6%	a=10%
1	2	1	2	3	2	2
2	2	1	2	3	2	2
3	2	1	2	3	2	2
4	2	1	2	1	2	2
5	2	1	2	1	2	2
6	2	1	2	3	2	2
7	2	1	2	3	2	2
8	2	1	2	1	2	2
9	2	1	2	1	2	2
10	2	1	2	3	2	2

Comparing results in Tables 5 and 9, it can be seen that the optimal place of Diesel t for a=2% doesn't change during 10 years when LFU is considered. The number of displacements of Micro turbine is also the same as that obtained in section V. However, the optimal location for Diesel unit in 10th year for a=6% is different with corresponding location for a=2, 10%, when LFU is considered. Also, optimal place of Micro turbine for a=2% is different with associated places for a=6, 10%.

Obtained values for BCR , $Benefit_{DG}$, $Cost_{DG}$ and corresponding $Pr\ ofit$ of solution in the case of $\sigma = 2\%$, are presented in Table9 :

Table 9. Economical indices of results associated with LFU ($\sigma = 2\%$)

Load growth rate	BCR	$Benefit_{DG}$ (\$)	$Cost_{DG}$ (\$)	$Pr\ ofit_{DG}$ (\$)
2%	1.7762	16613700	9353500	7260200
6%	3.0187	25228400	8357400	16871000
10%	3.4832	29111000	8357400	20753600

Fig. 6 illustrates the variation in BCR during study period for all the load growth rates in the case of $\sigma = 2\%$.

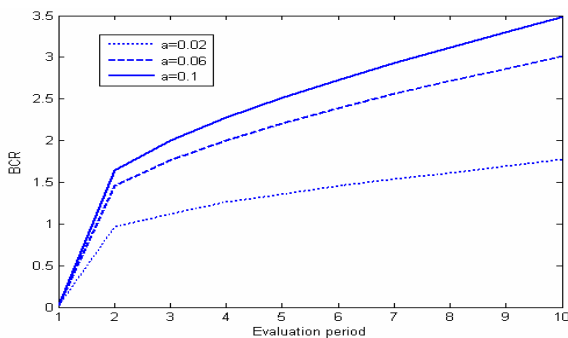

Fig. 6. BCR variation during 10 years ($\sigma = 2\%$)

Comparing Fig 4 and 6, it can be seen that in the case of load forecast uncertainty, the BCR for each load growth rate, reach to lower value than in the case of non-uncertainty for load forecast.

VII. CONCLUSION

A method is proposed to find optimum location of a utility-owned DG during the study period. The method uses a cost/worth analysis approach which considers DG costs and benefits to both utility and customers. Particularly, the DG is assumed to be portable and the optimum location is found for each year of the study period to maximize the benefit to cost ratio of DG application. Considering operational constraints of the network and mechanical constraint of DG displacement, the problem is solved using a forward dynamic programming approach.

The method was then applied to a distribution test system and the impact of various load growth rates was studied. Results showed that the number of DG displacement decreases where the BCR of DG application increases as the load growth rate increases. The method was then extended to incorporate load forecast uncertainty supposing a normal probability distribution for anticipated peak load. The impact of different load forecast uncertainties were studied. Results showed that the optimal DG location can be different form that obtained without considering load forecast uncertainty.

VIII. REFERENCES

- [1] S.M. Moghadas-Tafreshi, "Electrical Energy Generation Resources in 21st century", k.N. Toosi University of Technology Press, 1st Edition, Tehran, 2005.
- [2] M. Fotuhi-Firuzabad, Abbas Rajabi-Ghahnavie, "An Analytical Method to Consider DG Impacts on Distribution System Reliability" IEEE/PES Displacement and Distribution Conference&Exhibition, Asia and Pacific, 2005.
- [3] Jeo-Hao, Teng, Yi-Hwa, Liu, Chia-Yen, Chi-Fa Chen, "value-based distributed generator placements fir service quality improvements", Paper Presented in Electrical Power and Energy Systems 29 Journal, 2007, pp.268-274.
- [4] Rosehart W, Nowicki E, " Optimal Placement of Distributed Generation", Proceeding of 14th Power Systems Computation Conference section 11, Sevillaa 2002, pp.1-5
- [5] Silvestri a, Berrizi A, Buonanno S, "Distributed Generation Planning Using GA", IEEE PowerTech, Budapest, 1999
- [6] Celli G, Pilo F., "Optimal Distributed Generation Allocation in MV Distribution Networks", IEEE PES Conference on Power Industry Computer Applications, PICA 2001, Australia, 2001, pp.81-86.
- [7] (2007) Digsilent, Power System Calculation Package, Available: <http://www.Digsilent.de/software>
- [8] R.Billinton and R N. Allan "Reliability Study of Power Systems" Plenum press-New York, Second Edition, 1994.
- [9] R.Billinton and R. N Allan "Reliability Calculation of Engineering Systems: Concepts and Techniques" Plenum Press, New York, Second Edition, 1998.
- [10] Allen J.Wood and Bruce F. Wollenberg, "Power Generation, Operation and Control", John Wiley and Sons Press, New York, Second Edition, 1998
- [11] H.Lee Willis and Walter G.Scott "Distributed Power Generation: Planning and Study" Marcel Dekker press-New York, 2000.

XI. BIOGRAPHIES



M. Ahmadi-Gorji. was born in Iran in 1984. Obtained his B.Sc. and M.Sc. Degrees in Electrical Engineering from Khajeh-Nasir Toosi University of Technology and Sharif University of Technology, Tehran, Iran in 2006 and 2008, respectively. His areas of interests are power system optimization, Distribution system planning, Distributed Generation (DG) and application of DG in power system studies.



A. Abbaspour, was born in Iran. Obtained his B.Sc. and M.S.c degrees and PhD. Degrees in electrical engineering from Amirkabr University of Technology, Tehran, Iran, and Tehran University, respectively and PhD. Degree in Electrical Engineering from the University of Brekley, California, USA in 1983. His areas of interest are Distributed Generation (DG), new energy, power plant technology and Nuclear power plant technology. Presently. He is an associate professor in Electrical Engineering Department of Sharif University of Technology.



A. Rajabi-Ghahnavieh, (IEEE Student Member, 08) was born in Iran in 1981. Obtained his B.Sc. and M.Sc. Degrees in Electrical Engineering from Isfahan University of Technology, Isfahan, Iran, in 2002 and Sharif University of Technology, Tehran, Iran in 2004, respectively. Presently, he is a joint PhD student

in Department of Electrical Engineering, Sharif University of Technology, Tehran, Iran and the Electrical Engineering laboratory of the Institute National Polytechnique de Grenoble (INPG), France. His areas of interest are reliability assessment of power system and application of probabilistic methods in power system studies.



M. Fotuhi-Firuzabad (IEEE Senior Member, 99) was born in Iran. Obtained B.Sc. and M.Sc. Degrees in Electrical Engineering from Sharif University of Technology and Tehran University in 1986 and 1989 respectively and M.Sc. and Ph.D. Degrees in Electrical Engineering from the University of Saskatchewan in 1993 and 1997 respectively. Dr. Fotuhi-Firuzabad worked as a postdoctoral fellow in the Department of Electrical Engineering, University of Saskatchewan from Jan. 1998 to Sept. 2000 and

from Sept. 2001 to Sept. 2002 where he conducted research in the area of power system reliability. He worked as an assistant professor in the same department from Sept. 2000 to Sept. 2001. Presently he is an associate professor and Head of the Department of Electrical Engineering, Sharif University of Technology, and Tehran, Iran. Dr. Fotuhi-Firuzabad is a member of center of excellence in power system control and management in the same department.