

On Climbing Winding Stairs for a Robotic Wheelchair

Chun-Ta Chen Te-Tan Liao Hoang-Vuong Pham

Abstract—In this paper motion analysis on a winding stair-climbing is investigated using our proposed rotational arm type of robotic wheelchair. For now, the robotic wheelchair is operated in an open mode to climb winding stairs by a dynamic turning, therefore, the dynamics model is required to ensure a passenger's safety. Equations of motion based on the skid-steering analysis are developed for the trajectory planning and motion analysis on climbing winding stairs. Since the robotic wheelchair must climb a winding staircase stably, the winding trajectory becomes a constraint equation to be followed, and the Baumgarte's method is used to solve for the constrained dynamics equations. Experimental results validate the behavior of the prototype as it climbs a winding stair.

Keywords—Climb, robotic wheelchair, skid-steering, winding stair .

I. INTRODUCTION

NOWADAYS, electric powered wheelchairs are very common and efficient for transportation of the old and the disabled, it is certain that electric powered wheelchairs can improve the mobility of physically handicapped people. Although an electric powered wheelchair is more and more important to play the assistant roles, and may bring a happiness and convenience to those who need it, however, architectural barriers like stairs still exist in our living environments to prevent from usefulness. Whilst numerous modifications have been taken in recent years to improve the accessibility of public buildings and transportation services, the problem of negotiating stairs in a wheelchair has not yet been satisfactorily resolved.

Various stair mobility assistance devices have been proposed in recent decades. Many of these devices utilize mechanical leg-type structures to accomplish a dynamic walking or stair-climbing ability [1-3]. However, whilst such legged wheelchairs provide the ability to negotiate staircases or slopes, they require the use of complex algorithms to control the dynamics of the system in a safe and stable manner. Moreover, such locomotion systems are inefficient when utilized to achieve motion in the horizontal plane. Accordingly, some researchers have proposed track-based systems as a means of resolving the stair navigation problem whilst retaining a satisfactory planar navigation capability [4,5]. Such systems

offer better mobility on natural terrains than legged systems. However, accomplishing the stair-climbing maneuver requires a very high grip force to be continuously maintained at the edge of each step. Furthermore, such systems generally utilize an open-loop control mode, and thus ensuring a stable and comfortable ride whilst navigating the stairs is not easily achieved.

Researchers have also proposed stair-climbing systems based on the use of articulated wheel clusters arranged on a rotational link [6,7]. For example, an iBOT 3000 transportation system is based on a two-wheel cluster design, in which the dynamic balance of the wheelchair whilst performing a stair-climbing maneuver was maintained by a closed-loop servo control algorithm via a complex control system comprising tilt sensors, gyroscopes, encoders and computers [8].

Several systems combining mechanical legs with rotating wheel clusters have also been proposed in recent years [9,10]. Lawn and Ishimatzu [11] developed a mechanism comprising eight wheels attached to a rotating link, and optimized the design to enable the wheelchair-assisted ascent and descent of stairs with a high step height in a forward direction. The feasibility of the proposed design was demonstrated by performing single-step entry and exit maneuvers using a scale model of a van. However, such single-step devices have multiple degrees of freedom, and thus sophisticated control schemes are required to ensure a smooth trajectory of the wheelchair during the maneuver. The other staircase-climbing wheelchair featuring two decoupled mechanisms on each axle is proposed, namely one mechanism to negotiate the individual steps in the staircase, and a second mechanism to adjust the position of the axle relative to the chair in accordance with the overall slope of the staircase [12,13].

In most hybrid legged-wheeled staircase-climbing systems, the wheels serve as contact soles when climbing the stairs. However, if the wheels are too large, they only make contact at the edges of each step. Conversely, a small wheel radius improves the contact area on the stair, but reduces the efficiency of the system when navigating planar terrains. Moreover, these mentioned machines only demonstrate stair-climbing maneuvers, no one shows to ascend or descend winding stairs. Accordingly, building upon the work performed by the current group in a previous study [14], this paper investigates the motion analysis on winding stair-climbing for our developed enhanced stair-climbing robotic wheelchair.

C-T Chen and H-V Pham are with the Department of Mechanical and Automation Engineering, Da Yeh University, 112 University Rd., Da Tsuen, Changhwa, Taiwan 515 (886-4-851-1888#2467; e-mail: ctchen@mail.dyu.edu.tw).

T-T Liao is with the Department of Mechanical Engineering Far East University, No.49, Chung Hua Road, Hsin-Shih, Tainan, Taiwan 744 (e-mail: ttliao@cc.feu.edu.tw).

II. MECHANICAL SYSTEM DESCRIPTION

As shown in Fig. 1, the proposed robotic wheelchair comprises a base attached on either side to a mechanical structure comprising a short arm, a long arm and a pair of triangular supports, each carrying a crawler tractor and a wheel, respectively. In each structure, the two limbs are pivotally mounted such that each is capable of rotating independently of the other under the actuating effects of the corresponding epicyclical gear train.

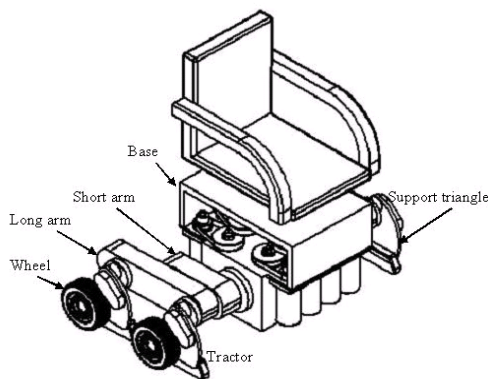

Fig. 1. Schematic illustration of the rotational arm of robotic wheelchair

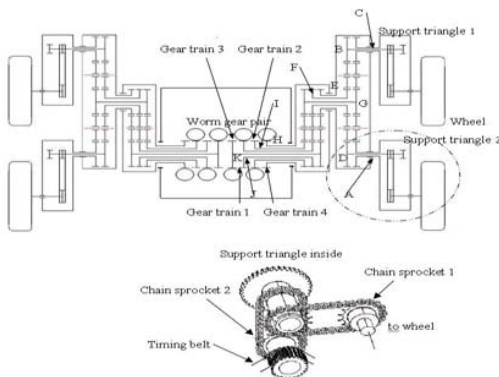

Fig. 2. Details of robotic wheelchair actuation mechanisms

Fig. 2 shows the components within each mechanical structure driven by a total of four transmission gear trains. The short arm is driven directly by worm gear pair 4 through the hollow shaft H, while the long arm is driven by gear train 3 through hollow shaft E. In addition, the rotation of the triangular supports is actuated by gear train 2, while the wheel and crawler tractor attached to each triangular support are driven by gear train 1 via chain & sprocket 1 and chain & sprocket 2, respectively.

The two triangular supports on each long arm carry a wheel (to accomplish navigation over a planar surface) and a crawler tractor (to serve as a contact sole when performing ascent and descent maneuvers). The wheel and crawler tractor are mounted pivotally at the base of each triangular support and are spaced in such a way that when the crawler tractor is in contact with the ground, the wheel is raised, while when the wheel is in contact with the ground, the crawler tractor is raised

III. STAGES OF THE CLIMBING STAIRS

The basic steps in the maneuver can be summarized as follows:

- 1) When navigating a planar surface, a locomotion effect is obtained via the four wheels mounted on the triangular supports, and the base is maintained in a central position relative to the mid-points of the two long arms. However, when performing a stair-climbing maneuver, the triangular supports are rotated such that the crawler tractors make contact with the ground and the base is driven forward relative to the mid-point of the two long arms so as to ensure a statically stable condition.
- 2) During the stair-climbing maneuver, the long and short arms on either side of the base rotate synchronously with the same angular velocity about shafts K and D, respectively. In the initial stride, the crawler tractor mounted on triangular support 2 remains on the ground (together with those on both supports on the opposite side of the base) while triangular support 1 is rotated in the upward and forward direction such that the crawler tractor mounted on its lower surface makes contact with the ground (i.e. the step) in front of triangular support 2. Since hollow shaft E connects to the housing used to rotate the long arm, it can be viewed as an input arm. Furthermore, during the first stride, the crawler tractor on triangular support 2 remains in contact with the ground at all times, and thus the long arm and all the other assemblies revolve about shaft D. Consequently, the orientation of triangular support 1 remains unchanged as the long arm rotates. As a result, the system not only achieves a rotational-type gait, but also ensures that the crawler tractors remain parallel to the ground at all times without the need for an active servo mechanism to constantly re-adjust their orientation as the long arm rotates.
- 3) The procedure described in Step 2 is repeated on the opposite side of the base.
- 4) The base is driven upward and forward along a circular path by turning the two short arms simultaneously about shafts G on either side of the base until the short arms are parallel to the long arms once again.
- 5) The procedures described above are repeated for the next step in the staircase.

The process of maneuvering down the staircase is accomplished by performing the sequence of motions described above in reverse.

IV. DYNAMICS BASED ON SKID-STEERING ANALYSIS

In this section the dynamic equations on climbing winding stairs will be developed considering the design of the robotic wheelchair. A body-fixed frame G-xy is attached to the center of gravity of the robotic wheelchair. The x-axis is along the heading direction of the robotic wheelchair, as shown in Fig. 3. The position of wheelchair robot is specified by the location of its center of gravity, and the orientation is defined by the heading direction ϕ of the robotic wheelchair relative to the

inertial frame O-XY. The external forces acting on the wheelchair robot consist of the gravity force Mg , the active forces F_i and F_o , the resistant forces R_i and R_o .

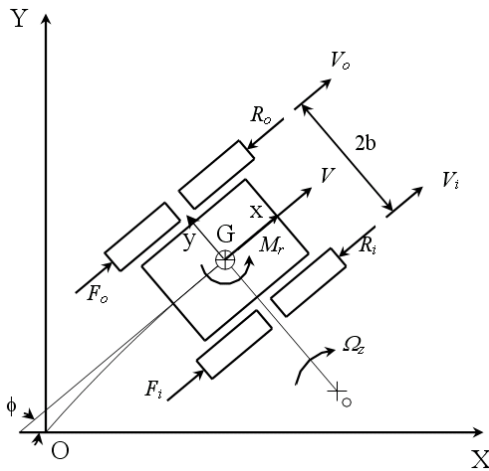

Fig. 3. Winding stair-climbing based on skid-steering analysis

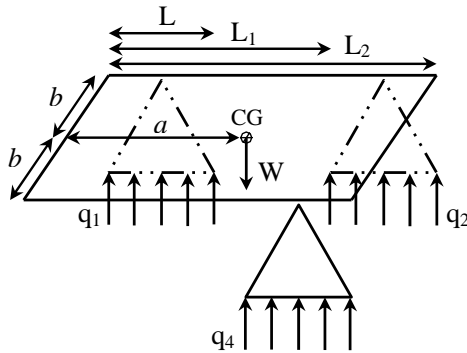

Fig. 4. Normal pressures at the first stage

The robotic wheelchair will carry a person to ascend or descend stairs, velocity should be small enough for safety so that the centrifugal force on the turns will be neglected. The turning behavior, similar to a tracked vehicle using skid-steering, depends on the thrusts F_i and F_o of the outside and inside tracks, the resultant resisting force R_o and R_i , the moment of turning resistance M_r exerted on the track by the ground; v is the heading speed; m is the mass of robotic wheelchair; b is a half of the width of the robotic wheelchair; D is moment of turning resistance exerted on the track by the ground. The behavior of the vehicle can be described by the following equations of motion in the inertial frame as

$$m\ddot{X} = -m\dot{\phi}\dot{Y} + \cos\phi(F_o + F_i - R_o - R_i) \quad (1)$$

$$m\ddot{Y} = m\dot{\phi}\dot{X} + \sin\phi(F_o + F_i - R_o - R_i) \quad (2)$$

$$I\ddot{\phi} = (F_o - F_i - R_o + R_i)b - D \quad (3)$$

Whilst the wheelchair robot ascends and descends winding stairs in a dynamic turning, there are three stages for climbing each step. So the turning resistant moment D in Fig. 4 should be calculated. The L , L_1 and L_2 are defined as a length of the tractor, a distance from front axis to rear axis and a length of the robotic wheelchair.

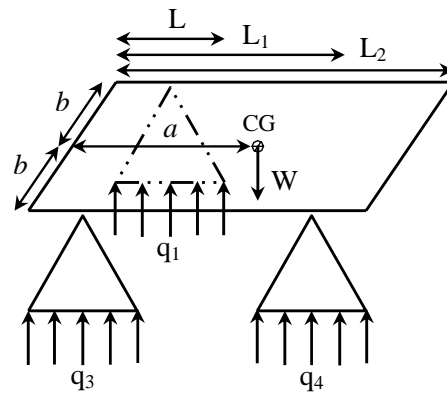

Fig. 5. Normal pressures at the second stage action

Assume that the normal pressure on track is distributed uniformly, based on the static equilibrium, the normal pressures q_1 , q_2 and q_4 can be calculated. As explained above, the location of the center of gravity of the robotic wheelchair varies with the climbing locomotion, therefore, the normal pressures are calculated. According to the following cases.

If $a \leq L_1$, the moment of turning resistance will be computes as followings:

$$D = P_1(a - L/2) + (P_2 + P_3)(L_2 - L/2 - a) \quad (4)$$

And if $a > L_1$, the moment of turning resistance will be computes as followings:

$$D = P_1(a - L/2) + (P_2 + P_3)(a - L_1)/2 + (P_3 + P_4)(L_2 - a)/2 \quad (5)$$

P_1, P_2, P_3 are the lateral frictional force) and will be computed as $P_1 = \mu_f q_1 L; P_2 = \mu_f q_2 L; P_3 = \mu_f q_3 L$

For the second stage, the tractor in the other side of the body lifts up the ground, the normal pressures on tractors contacting to ground. if $a < L$ the moment of turning resistance can be computes as followings:

$$D = (P_1 + P_3)a/2 + (P_2 + P_4)(L - a)/2 + P_3(L_2 - L/2 - a) \quad (6)$$

if $a \geq L$, the moment of turning resistance will be computes as followings:

$$D = (P_1 + P_3)(a - L/2) + P_2(L_2 - L/2 - a) \quad (7)$$

For the third stage, the body moves in a circular path by rotation the short arms, the normal pressure on put in each tractor is shown in figure. In this action, the moment of turning resistance will be computes as followings:

$$D = 2P_1(a - L/2) + 2P_2(L_2 + L/2 - a) \quad (8)$$

V. TRAJECTORY GENERATION FOR WINDING STAIRS

In order to climb a winding stair in an open mode, the robotic wheelchair must follow a circular trajectory, therefore, the circular path can be viewed as a constraint which will be described as the trajectory of centre of gravity of the robotic wheelchair., and then the Baumgarte stability method and coordinate reduction method are applied to determine the trajectory of the robotic wheelchair.

Equations. (1)-(3) can be expressed in a matrix form as

$$\ddot{x} = f \quad (9)$$

in which $x = [X \ Y \ \phi]^T$, and

$$\mathbf{f} = \begin{bmatrix} -\dot{\phi}\dot{Y} + \cos\phi(F_0 + F_i - R_0 - R_i) \\ \dot{\phi}\dot{X} + \sin\phi(F_0 + F_i - R_0 - R_i) \\ ((F_0 + F_i - R_0 - R_i)b - D)/I \end{bmatrix} \quad (10)$$

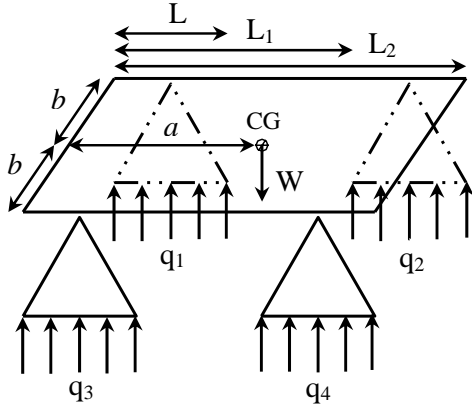

Fig. 6. Normal pressures at the third stage

Because the centre of gravity of the robotic wheelchair moves along a circle which is defined as following as

$$\mathbf{h} = \begin{bmatrix} X - R(1 - \cos\phi) \\ Y + R\sin\phi \end{bmatrix} = 0 \quad (11)$$

The trajectories of the robotic wheelchair can be planned by differentiating (11) such that

$$\dot{\mathbf{h}} = \mathbf{B}\dot{\mathbf{x}} = \begin{bmatrix} 1 & 0 & -R\sin\phi \\ 0 & 1 & R\cos\phi \end{bmatrix} \dot{\mathbf{x}} = 0 \quad (12)$$

$$\ddot{\mathbf{h}} = \mathbf{B}\ddot{\mathbf{x}} + \dot{\mathbf{B}}\dot{\mathbf{x}} = 0 \quad (13)$$

Equations (11)(12) are substituted into (9), and the required thrusting forces F_0, F_i can be solved using (9)(10).

In order to analyze the corresponding winding stair-climbing motion by simulation, the Baumgarte method is introduced to assure asymptotic stability by using the following expression for the constraints as

$$\ddot{\mathbf{h}} + [\alpha]\dot{\mathbf{h}} + [\beta]\mathbf{h} = 0 \quad (14)$$

in which the elements of the diagonal constant matrix $[\alpha]$ $[\beta]$ must satisfy $\alpha_i > 0$ and $\alpha_i^2 - 4\beta_i \leq 0$ to achieve asymptotical stability. Substituting (12) (13) into (14), the constraints are expressed as

$$\mathbf{B}\ddot{\mathbf{x}} = -(\dot{\mathbf{B}} + [\alpha]\mathbf{B})\dot{\mathbf{x}} - [\beta]\mathbf{h} \quad (15)$$

Further, the coordinate reduction method is applied to (9), the equations of motion will become

$$\mathbf{T}\ddot{\mathbf{x}} = \mathbf{T}\mathbf{f} \quad (16)$$

in which applied matrix $\mathbf{T} = [R\sin\phi \quad -R\cos\phi \quad 1]$ satisfies

$$\mathbf{T}\mathbf{B}^T = 0 \quad (17)$$

Equations (15)(16) are used for the motion analysis for the robotic wheelchair.

VI. SIMULATION AND EXPERIMENTAL RESULTS

A winding stair, which is based on ISO 7176-24, is used for the simulations and experiments. The winding stair has nineteen steps in one circle and each step is 19° . The required

thrusting forces for climbing the specified winding stair are shown in Fig. (7). It is noted that the forces are for only three steps. The peaks in the figures are resulted from the transition of each climbing stages. Fig. 8 shows the trajectories of the center of gravity of the robotic wheelchair and its body respectively. Because the trajectory is planned with respect to the center of gravity of the robotic wheelchair, the path of its body fluctuates. However, the body is for a mounted seat, it may be better to plan trajectories with respect to the body of the robotic wheelchair. The 3D trajectory is shown in Fig. 9 to validate the development of the equations of motion.

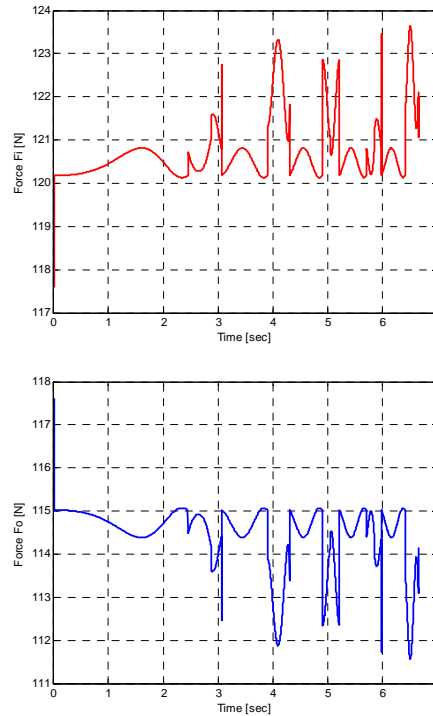

Fig. 7. Required thrusting forces for the specified winding stair

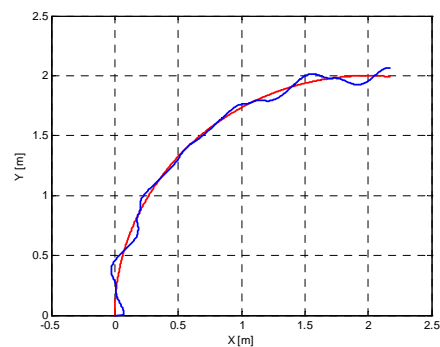

Fig. 8. The trajectories of the center of gravity (Red line) and the center of body (Blue line) in XY-plane

The experiment is implemented using the designed robotic wheelchair. The climbing processes are shown in Fig. 10(a)-(h). It is seen that the robotic wheelchair can overcome the winding

staircase while keeping its body level.

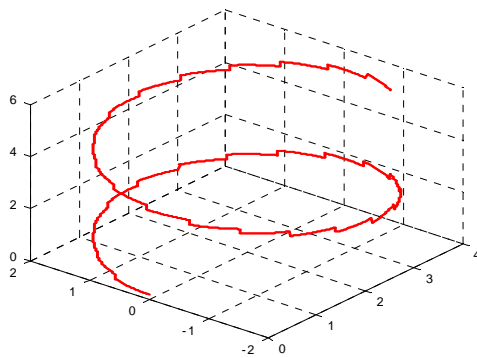

Fig. 9 Trajectory of the center of gravity of the robotic wheelchair on climbing the specified winding stair

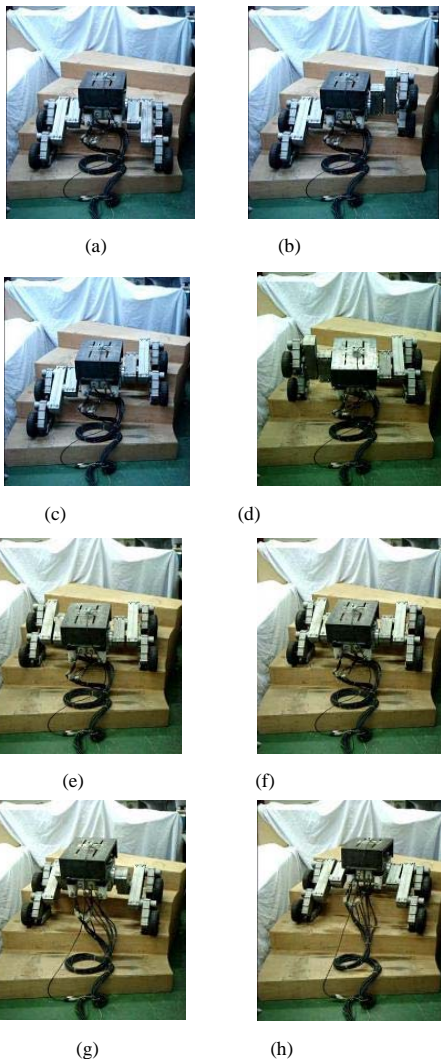

Fig. 10(a)-(h) Photographs of experimental trial on winding stair-climbing

VII. CONCLUSION

This paper presents a novel stair-climbing robotic wheelchair in which a pair of rotational multi-limbed structures pivotally mounted on opposite sides of a rigid support base are driven using epicyclical gear trains in such a way as to achieve a rotational-type gait. In this way, the robotic wheelchair can climb stairs, especially climb winding stairs.

Moreover, the equations of motion for the winding stair-climbing analyses are developed, and the trajectories are planned when the robotic wheelchair is operated in an open mode. Simulation results present the required thrusts and the corresponding motion. Experimental trials also demonstrate that our proposed robotic wheelchair can ascend a winding staircase successfully.

In the future, the trajectories will be planned with respect to the body considering an operator's comfort. In addition, a feedback controller will be designed to climb the winding stairs more robust.

ACKNOWLEDGMENT

This work is supported by the National Science Council of the ROC under the Grant NSC 98-2221-E-212 -026.

REFERENCES

- [1] P. Wellman., V. Krovi, V. Kumar and W. Harwin, "Design of a wheelchair with Legs for people with Motor Disabilities", *IEEE Transactions on Rehabilitation Engineering*, Vol.3, No. 4, pp. 343-353, 1995.
- [2] S. Hirose, K. Yoneda, K. Arai and T. Ibe, "Design of a quadruped walking vehicle for dynamic walking and stair climbing", *Advanced Robotics*, Vol. 9, No. 2, pp. 107-124, 1995.
- [3] D. J. Pack, "Perception-based control for a quadruped walking robot", in Proceedings of the IEEE International Conference on Robotics and Automation, 1996, pp. 2994-3001.
- [4] J. D. Martens and W. S. Newman "Stabilization of a mobile robot climbing stairs", in Proceedings of the IEEE International Conference on Robotics & Automation, 1994, pp. 2501-2507.
- [5] T. Kagiwada, "Robot design for stair navigation", *JSME International Journal, Series C: Dynamics, Control, Robotics, Design and Manufacturing*, Vol. 39, No3, pp. 629-635, 1996.
- [6] Taguchi, K., "Enhanced wheel system for step climbing", *Advanced Robotics*, Vol. 9, No. 2, pp. 137-147, 1995.
- [7] Y. Uchida, K. Furuichi and S. Hirose, "Fundamental performance of 6 wheeled off-road vehicle HELOS-V", in Proc. of the 1999 IEEE International Conference on Robotics & Automation, pp. 2336-234, 1999.
- [8] D. Din and R. A. Cooper, "Electric-powered wheelchair", *IEEE Control Systems Magazine*, pp. 22-34, 2005.
- [9] M. Miyagi, T. Uchida, T. Komeda, H. Komeda and H. Funakubo, "Development of stair climbing wheelchair with legs and wheels system (1st Report)-Development of stair climbing mechanism", *Journal of the Japan Society for Precision Engineering*(in Japanese), Vol.64, No.3, pp. 403-407, 1998.
- [10] N. G. Bourbakis, "Kydonas-an autonomous hybrid robots: walking and climbing", *IEEE Robotics & Automation Magazine*, pp. 52-59, 1998.
- [11] M. J. Lawn and T. Ishimatsu, "Modeling of a stair-climbing wheelchair mechanism with high single-step capability," *IEEE Transaction on Neural Systems and Rehabilitation Research*, Vol. 11, No. 3, pp. 323-332, 2003.
- [12] R. Morales, V. Feliu, A. Gonzalez and P. Pintado, "Kinematic model of a new staircase climbing wheelchair and its experimental validation", *The international Journal of Robotics Research*, Vol. 25, No. 9, pp. 825-841 .2006.

- [13] A. Gonzalez, R. Morales, V. Feliu and P. Pintado, "Improving the mechanical design of new staircase wheelchair", *Industrial Robot: An International Journal*, Vol. 34, No. 2, pp. 110-115, 2007.
- [14] C. Chen, C. Feng and Y. Hsieh, "Design and realization of a mobile wheelchair robot for all terrains", *Advanced Robotics*, Vol. 17, No. 8, pp. 739-760, 2003.