

Numerical Modeling of Natural Convection on Various Configuration of Rectangular Fin Arrays on Vertical Base Plates

H.R.Goshayeshi, M.Fahiminia, and M.M.Naserian

Abstract—In this research, the laminar heat transfer of natural convection on vertical surfaces has been investigated. Most of the studies on natural convection have been considered constantly whereas velocity and temperature domain, do not change with time, transient one are used a lot. Governing equations are solved using a finite volume approach. The convective terms are discretized using the power-law scheme, whereas for diffusive terms the central difference is employed. Coupling between the velocity and pressure is made with SIMPLE algorithm. The resultant system of discretized linear algebraic equations is solved with an alternating direction implicit scheme. Then a configuration of rectangular fins is put in different ways on the surface and heat transfer of natural convection on these surfaces without sliding is studied and finally optimization is done.

Keywords—Natural convection, vertical surfaces, SIMPLE algorithm, Rectangular fins.

I. INTRODUCTION

THIS document is a Natural convection is observed as a result of the movement of fluid because of density changes which is caused by heating process. A radiator used for warming the house is an example of a practical equipment for heat transfer of natural convection. The movement of fluid, whether gas or liquid, in natural convection is caused by buoyancy force due to density reduction beside to heat transfer's surfaces in heating process. When the domain of an exterior force such as gravity, has no effect on the fluid then will be no buoyancy force and heat transfer will be in the form of conduction. But gravity is not the only force causing natural convection. When a fluid is confined in the rotating machine, centrifugal force is exerted on it and if one surface or so, with more or less temperature than that of the fluid are in touch with the fluid, natural convection flows will be experienced. The fluid which is adjacent to the vertical surface with constant temperature, and the fluid temperature is less than the surface temperature, a velocity boundary layer forms the natural convection. The velocity profile in this boundary layer is completely different with the velocity profile in forced convection. The velocity is zero on the wall due to lack of

sliding. Then the velocity goes up and reaches its maximum and finally is zero on the external border of velocity boundary layer. Since the factor that causes the natural convection, is temperature gradient, the heating boundary layer appears too. The temperature profile has also the same value as the temperature of wall due to the lack of particles sliding on the wall, and temperature of particles goes down as approaching to external border of temperature boundary layer and it would reach the temperature of far fluids. The initial boundary layer enlargement is laminar, but in the distance from the uplifting edge, depending on fluid properties and the difference of temperature of wall and the environment, eddies will be formed and movement to turbulent zone will be started. Today being more aware about energy sources' limitations and also increase demand for energy consumption from one side and considerable waste of energy in heating systems from the other side, have caused the societies to investigate on energy systems and find solutions for reducing energy dissipation from these systems. There are many appliances in engineering in which two environments with different temperatures are separated by a wall or a thin surface. The wall on one side is getting warm and on the other side is making the beside fluid warm. Heat transfer between the two environments and the temperature of the wall, depends on the shape of the boundary layers on the wall surfaces. The amount of temperature on the wall will reach a balance of the temperature of both environments.

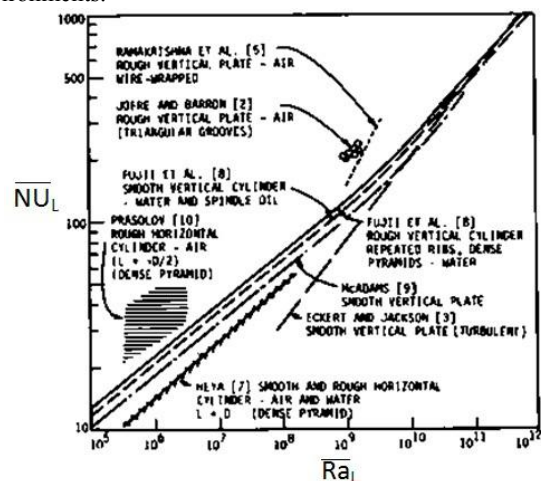

Fig. 1 A number of reports in the field of heat transfer of natural convection on extended surfaces.

F. A. H.R.Goshayeshi is with the Department of Mechanical Engineering, Islamic Azad University, Mashhad Branch, Iran (corresponding author, (e-mail:goshayeshi@yahoo.com).

S. B. M. Fahiminia is with the Department of Mechanical Engineering, Islamic Azad University, Mashhad Branch, Iran (e-mail:Maaahdi2003@gmail.com).

T. C. M.M.Naserian is M.Sc Student; Islamic Azad University, Mashhad Branch, Young Researchers Club; (e-mail: Mmahnas@yahoo.com).

Since the boundary layer of one side makes the boundary layer of the other side they are called conjugate boundary layers.

Although a lot of investigations have been done on natural convection heat transfer, the data the effect of geometrical complexes on natural convection heat transfer has many deficiencies. As in Fig. 1 a number of published results for extended surface has been gathered to provide a general image from the works done so far with different contexts [1]. Jofre and Barron have gathered some data on natural convection heat transfer, which the fluid is air, on the vertical surface with some swells in the shape of triangle ribs [2]. They concluded that at $Ra_L = 10^9$. The average Nusselt number is increased %200 compared to the average Nusselt of turbulent flow achieved by Eckert and Jackson [3].

Of course if the fact is considered that the flow on the flat surface is not turbulent on all the surface, and the data are compared with upstream flow that is assumed laminar flow, the results show %100 increase as compared to the recent one. We should say that this big difference is caused by the lack of attention to the correct way of radiation heat transfer [4].

Bhavani and Burgles after several experiments proved that making special changes on vertical surfaces (horizontal little fins) reduces heat transfer in the natural convection heat transfer process. This conclusion can cause changes in the ways of insulating heat repelling surfaces and in this respect is of great importance. On the other hand we face many practical technologies causing natural convection heat transfer on the fins vertical surfaces. This matter is more obvious in the electronic circuit in which segment duty cycle is highly effected by the duty cycle [5]. Rebert, Green, Chapman and others have offered five important advantages of algorithmic solving method [6], [7]. Numerical solution of the governing equations of boundary zones for vertical surfaces has been done by Helus and Churchill and step changes of surface temperature has been achieved [8], [9]. The results tend to stable state in great times and shows a minimum amount for Nusselt number. Most of the works in this field are true for low Prandtl and in high Prandtl, computing errors can not be negligible.

Although there are many articles about forced convection gas flow on vertical surfaces, there are quantitative research done about natural convection flow on surfaces with rectangular fins. In this paper, a complete numerical solution including developing and developed enlarged hydrodynamic and heating parts is presented to analyze natural convection flow on the extended vertical surface.

II. NUMERICAL MODELING

For analyzing the above mentioned matter, first the differential equation of the movement of this layer should be achieved. So y axis is on the horizon and x axis is erected vertically on the surface as in Fig. 2. 2-dimensional flow is considered with physical properties, fixed wall temperature, more than the entrance free flow temperature. So upward flow is produced by buoyancy force on the surface. Two ends of the surface are open towards the environment with free flow temperature. Compressibility effect in the free flow with low

velocity taken here, can be negligible, and just laminar flow regime can be considered [10]. Density conversion caused by temperature changes is exerted in buoyancy force is done by Boussinesq approximation. The equation of conservation of mass, momentum and the energy for stable and laminar flow is described follow [11], [12].

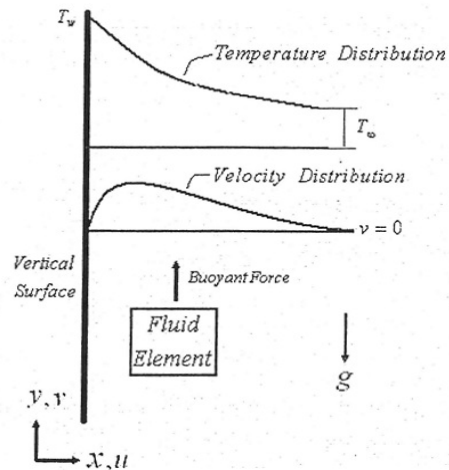

Fig. 2 Geometry and coordinate system

Continuity Equation:

$$\frac{\partial u}{\partial x} + \frac{\partial v}{\partial y} = 0. \quad (1)$$

X-Momentum Equation:

$$\rho \left(u \frac{\partial u}{\partial x} + v \frac{\partial u}{\partial y} \right) = - \frac{\partial p}{\partial x} + \nu \nabla^2 u + B_x \quad (2)$$

Y-Momentum Equation:

$$\rho \left(u \frac{\partial v}{\partial x} + v \frac{\partial v}{\partial y} \right) = - \frac{\partial p}{\partial y} + \nu \nabla^2 v - g. \quad (3)$$

Energy Equation:

$$\left(u \frac{\partial (\rho c_p T)}{\partial x} + v \frac{\partial (\rho c_p T)}{\partial y} \right) = \alpha \frac{\partial^2 T}{\partial y^2} \quad (4)$$

with boundary conditions:

$$\begin{cases} x = 0 \\ u = v = 0 \\ T = T_w \end{cases} \quad (5)$$

$$\begin{cases} x \rightarrow \infty \\ v = 0 \\ T = T_{\infty} \end{cases}$$

Assuming that there are not any parameter changes on x direction, (2) is omitted. Pressure gradient on "y" direction is caused by changes in height of the fluid. Out of velocity boundary layer, u, v, and their derivative are zero.

$$\frac{\partial p}{\partial y} = -\rho_{\infty} \cdot \quad (6)$$

with putting (6) in (3), we have:

$$u \frac{\partial v}{\partial x} + v \frac{\partial v}{\partial y} = -(\rho_{\infty} - \rho) + \frac{\mu}{\rho} \frac{\partial^2 v}{\partial x^2}. \quad (7)$$

Difference of density can be defined according to Thermal Expansion Coefficient.

$$\beta = -\frac{1}{\rho} \left(\frac{\partial \rho}{\partial T} \right)_P. \quad (8)$$

$$\beta \approx -\frac{1}{\rho} \frac{\rho_{\infty} - \rho}{T_{\infty} - T}.$$

$$u \frac{\partial v}{\partial x} + v \frac{\partial v}{\partial y} = -\beta(T_{\infty} - T) + \frac{\mu}{\rho} \frac{\partial^2 v}{\partial x^2}. \quad (9)$$

Above mentioned equation defines the momentum in natural convection velocity boundary layer, this momentum is caused by temperature gradient. So momentum equation (9) and energy equation (4) should be solved simultaneously because velocity and temperature are both unknown, since temperature depends on the velocity and vice versa. Now considering boundary conditions, temperature and velocity distributions are guessed and put in equations. Governing equations are solved using a finite volume approach. The convective terms are discretized using the power-law scheme, whereas for diffusive terms the central difference is employed. Coupling between the velocity and pressure is made with SIMPLE algorithm. The resultant system of discretized linear algebraic equations is solved with an alternating direction implicit scheme [13].

III. RESULT

In this paper, first, vertical surface is considered, then fin Configuration is put on the surface. Dimensions, distances between fins, the type of fins and the location they are put in, are considered. The dimensions are considered as shown in Table I.

TABLE I
DIMENSIONS OF THE FIN CONFIGURATIONS

FIN LENGTH L(MM)	FIN WIDTH W(MM)	FIN THICKNESS T(MM)	BASE THICKNESS D(MM)
80	59.8	1	1.4
FIN HEIGHT H(MM)	FIN SPACING S(MM)	NUMBER OF FIN N	
29.2	2.1	20	
29.2	3.9	13	
29.2	7.4	8	
29.2	18.6	4	

The mentioned geometrical Configuration as shown here.

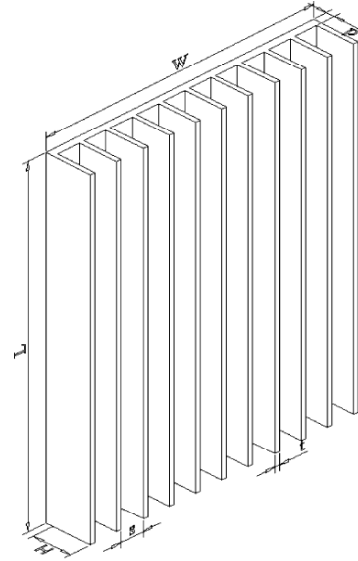

Fig. 3 Fin configuration geometry

The studies on different surfaces show that in fins with low distances, air flow between the fins is fully developed due to boundary layers interference, and therefore heat transfer rate is achieved by.

$$\dot{Q}_c^1 \text{ single channel} = \dot{m} C_p \Delta T. \quad (10)$$

$$\dot{m} \approx \frac{\rho \beta s^3 \Delta T}{\nu} H. \quad (11)$$

If $n = w/s$, then ,

$$\dot{Q}_c^1 \approx \frac{\rho \beta s^3 \Delta T}{\nu} H k \Delta T \frac{W}{S}. \quad (12)$$

$$\dot{Q}_c^1 \approx \frac{\beta s^3 \Delta T}{\nu \alpha} H k \Delta T \frac{W}{S}. \quad (13)$$

Unlike the previous way, if the fin distances are great, the boundary layer thickness is so much less than the distance between the fins and the space between the fins is like the flow in parallel surfaces in which boundary layers have no interference. Natural convection heat transfer of from two

surfaces of a fin is as follow:

$$\dot{Q}_c^1 \approx hA\Delta T. \tag{14}$$

In which heat transfer coefficient is defined as:

$$h \approx \left(\frac{\rho\beta L^3 \Delta T}{\nu\alpha}\right)^{\frac{1}{4}} \frac{k}{L}. \tag{15}$$

If A=H×L, then:

$$\dot{Q}_c^2 \approx \left(\frac{\rho\beta L^3 \Delta T}{\nu\alpha}\right)^{\frac{1}{4}} kH\Delta T \frac{W}{s}. \tag{16}$$

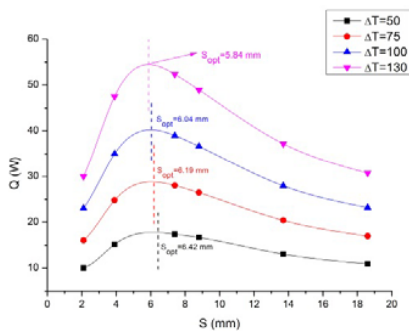

Fig. 4 Variation of convective heat transfer rate with base-to-ambient temperature difference at H=29.2 mm and L=80 mm

$\dot{Q}_c^1 \approx s^{-1}$, $\dot{Q}_c^2 \approx s^2$ is observed.

The investigations show that in the same fin length and height and constant difference of temperature, heat transfer rate first increases with increasing the fins distance, until reaches the maximum point and then decreases. The maximum point is called optimum distance between the fins, is the distance in which there is the maximum heat transfer. We can have an equation for the optimum distance, by interfering equation (12) and (16).

$$\frac{S_{opt}}{L} \approx Ra_L^{-\frac{1}{4}}. \tag{17}$$

For dimensionless presentation of the order of magnitude of optimum fin spacing, the Rayleigh number is employed according to its definition.

$$Ra_L = \left(\frac{\rho\beta L^3 \Delta T}{\nu\alpha}\right). \tag{18}$$

And according to our investigations on mentioned dimensions the optimum distance equation calculated as follow:

$$\frac{S_{opt}}{L} = 2.93Ra_L^{-\frac{1}{4}}. \tag{19}$$

As a point of departure for the presentation of heat transfer rates from fin-arrays are plotted as a function of temperature differences as in Fig. 5.

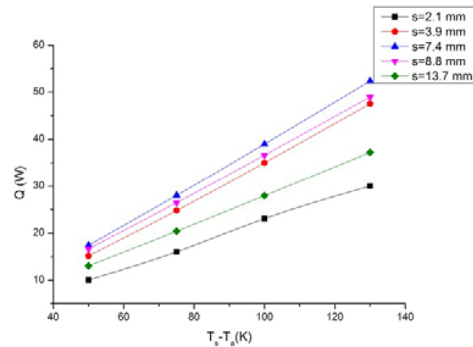

Fig. 5 Variation of convective heat transfer rate with fin spacing(fin height 29.2 mm)

From these Figs it can also be seen that, at a given fin height and temperature difference, the convection heat transfer rates increases with increasing fin spacing and reaches a maximum. With further increases of fin spacing, heat transfer rate starts to decrease. The occurrence of this maximum has significant practical applications for optimum performance of fin-arrays. It would be appropriate to manufacture the fin array with aforementioned fin height and spacing. The values of heat transfer coefficient obtained for an ambient air temperature of 27°C and plate surface temperatures of 77, 102, 127 and 157°C appear in Fig.6. As may be seen, the natural convection heat transfer coefficient increases substantially as the gap between fins increases from 2.1 to 18.6 mm, and then flattens out with further increases in gap. It may be noted that the values shown for a gap of 19 mm are within a few per cent of those obtained using a correlation for an individual vertical plate.

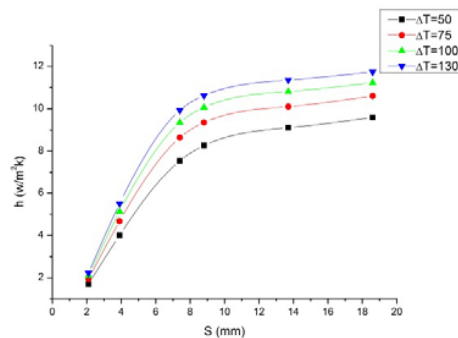

Fig. 6 Natural convection heat transfer coefficients for array of plates.

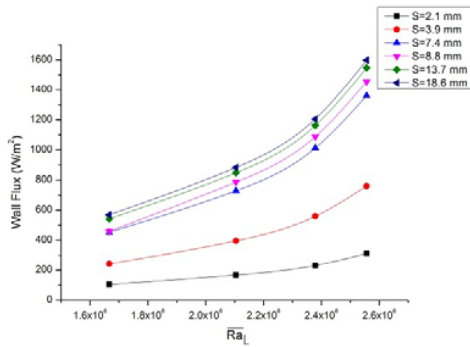

Fig.7 Variation of heat flux rate with Average Rayleigh number at H=29.2 mm and L=80 mm

The temperature at the upper surface of the heat sink base, the surface exposed to the operating fluid can then be found from (20), knowing the temperature at the bottom of the base by thermocouple measurement and the heat flux through the base.

$$T_w = T_{bp} - \left(\dot{Q}_c \frac{d}{kA} \right). \quad (20)$$

The heat flux at the base in W/m² is found with (20), knowing that the exposed base area is 4768 mm².

$$\dot{q}_c = \frac{\dot{Q}_c}{A}. \quad (21)$$

Finally, the heat transfer coefficient is calculated using (22) and the thermal resistance using (23).

$$h = \frac{\dot{q}_c}{(T_w - T_\infty)}. \quad (22)$$

$$R = \frac{(T_w - T_\infty)}{\dot{Q}_c}. \quad (23)$$

Refer to (22), (23), thermal Resistance has reverse relation to heat transfer coefficient.

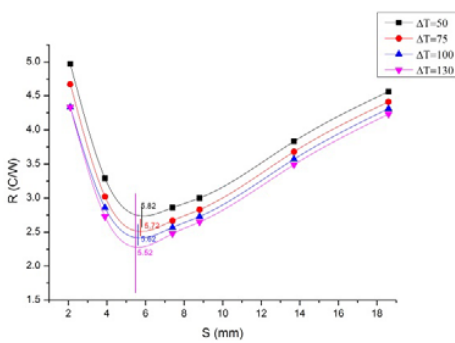

Fig. 8 Variation of thermal Resistance with heat transfer coefficient

As in Fig.9, average nusselt number is increased with increasing

average Rayleigh number and at a certain average Rayleigh number, average nusselt number is increased by increasing the distance between the fins.

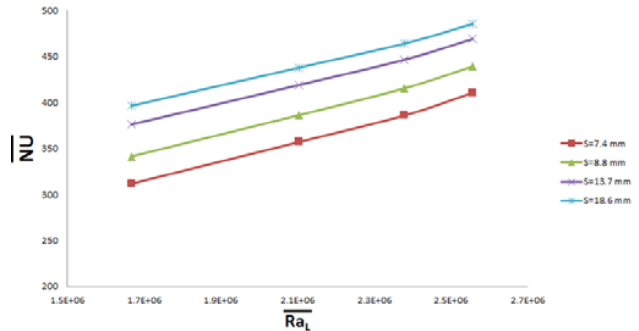

Fig. 9 Variation of average nusselt number with average Rayleigh number

According to above mentioned subjects and the diagrams, the optimum distance for vertical surface with fins of mentioned dimensions is S_{opt}=6.85, also is clear that if there are more fins, or reduce the distance between the fins, the rate of heat transfer increases. The length of the surface shouldn't be so big because increases the turbulence. if the distance between the fins are selected properly, there will be no interference between boundary layer and the surfaces. For stating the magnitude of for having the most heat transfer of convection of fins, we consider, on the fin surface, there comes the boundary layer immediately. in the other situation, we choose the distance between the fins big so that the thickness of boundary layer is smaller than the distance between the fins and increases without any interfering. Also, boundary layer interference is observed in Figs. 10 to 12.

TABLE II
UNITS FOR NATURAL CONVECTION HEAT TRANSFER

Symbol	Quantity	Unit
A	area	m ²
h	convection heat transfer coefficient	w/m ² k
T	temperature	°k
Cp	specific heat at constant pressure	kJ/kg°k
g	gravitational acceleration	m/s ²
H	fin height	m
k	thermal conductivity	w/m°k
L	fin length	m
\dot{m}	mass flow rate	kg/s
β	volumetric thermal expansion coefficient	1/°k
n	number of fins	
\dot{Q}_c^1	convection heat transfer rate from fins in small-s limit	w
\dot{Q}_c^2	convection heat transfer rate from fins in large-s limit	w
\dot{Q}_c	convection heat transfer rate	w
T _w	base plate temperature	°k
T _∞	ambient temperature	°k
W	base plate width	m
ν	kinematic viscosity	m ² /s
α	thermal diffusivity	m ² /s

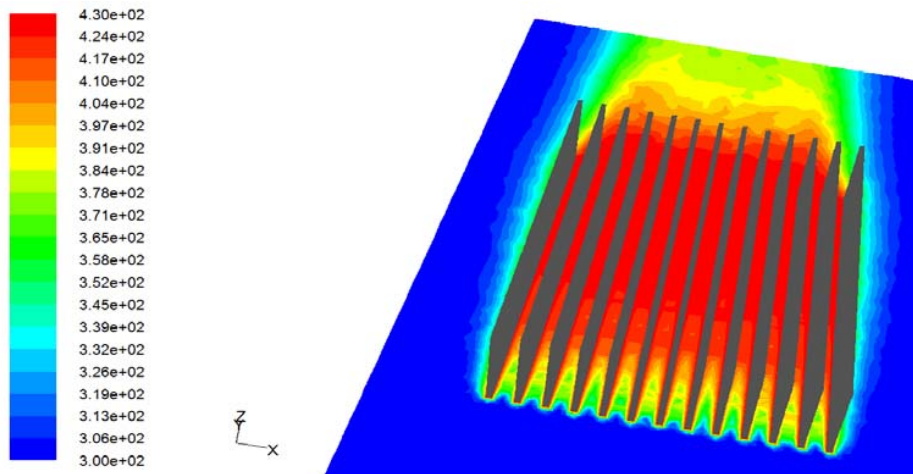

Fig.10 Variation of temperature contour of the heat sink (s=2.1mm)

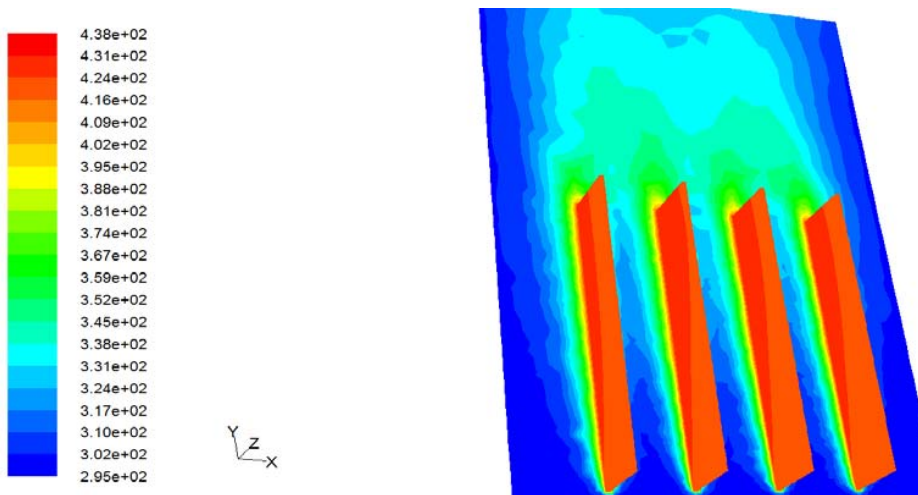

Fig.11 Variation of temperature contour of the heat sink (s=18.6 mm)

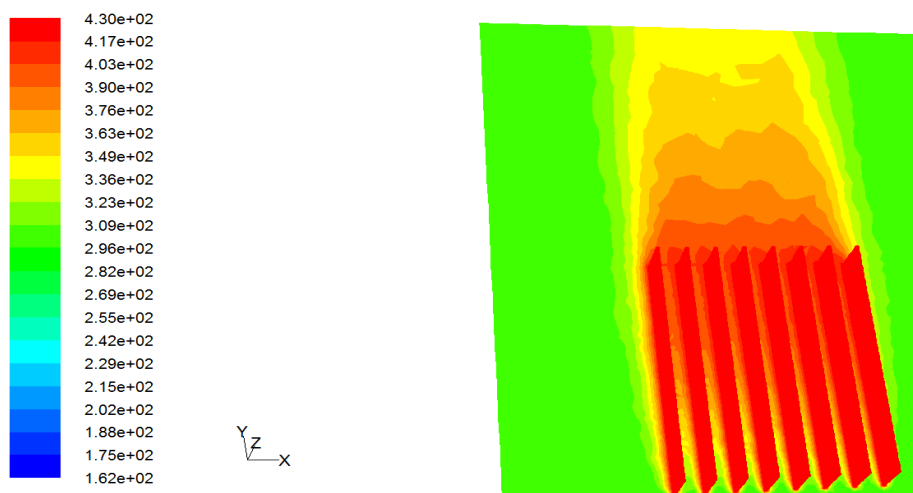

Fig. 12 Variation of temperature contour of the heat sink (s=7.4 mm)

REFERENCES

- [1] Bhavnani, S.H., Bergles, A.E. "Effect of surface geometry and orientation on laminar natural convection heat transfer from a vertical flat plate with transverse roughness elements" *Int.J.Heat Mass Transfer*, Vol. 44, No. 1, PP 155-167
- [2] Jofre, R.J., Baron, R. F "Free Convection heat transfer to a rough plate," ASME Paper No.67.
- [3] Ekert, E. R. Jackson, T.W., "Analysis of turbulent Free Convection Boundary on flat plate," NCA Report .1015 ,(1951)
- [4] Bergles, A.E., Junkhan, G.H, "Energy Conservation Via heat transfer management quarterly," Progress Report No. . Coo . 4649-59 January.31 March (1979)
- [5] Bhavnani, S.H., Bergles, A.E, "Effect of surface geometry and orientation on laminar natural convection heat transfer from a vertical flat plate with transverse roughness elements," *Int.J.Heat Mass Transfer*, Vol.43, No. 1, PP 135-121
- [6] Rubbert, P.E, "The emergence of advanced computational methods in the aerodynamic design of commercial Transport aircraft," in *Proc.Intsymp.comp.Fluid Dynamics*, Vol.1 ,PP.42-48
- [7] Green, J.E, "In numerical methods in aeronautical fluid Dynamics," ed .by P .L.Roe ,PP.1-39(1982)
- [8] Chapman, D.R., *J.A.I.A.A.*, Vol. 1, pp.293-1313,(1981)
- [9] Churchill, S.W., Usagi, "A general for the correlation of Rates of transfer and other Phenomena," *Alche J.* Vol. 18, PP.1121-1128(1979)
- [10] Kavehpour, H.P., Faghri, M., Asako, Y. 1997, "Effects of compressibility and rarefaction on gaseous flows in microchannels," *American Society of Mechanical Engineers Heat. Transfer Division (Publication) HTD*, pp. 41-47.
- [11] Gray, D., Giorgini, A., 1976, "The validity of the Boussinesq approximation for liquids and gases," *International Journal of Heat and Mass Transfer* 19: 545-551.
- [12] Patankar, S.V., 1980, "Numerical Heat Transfer and Fluid Flow," McGraw-Hill, New York
- [13] Harahap, F., Setio, D., "Correlations for Heat Dissipation and Natural Convection Heat-Transfer from Horizontally-Based, Vertically-Finned Arrays," *International Journal of Applied Energy*, Vol. 69, pp. 29-38, 2001.



Dr. Hamid Reza Goshayshi has an Honors Degree in Chemical Engineering, M. Sc. and Ph. D in Mechanical Engineering from South Bank University in London and did his post doctoral research on "Improvement of the Rankine Cycle." He was an Industrial Trainee Engineer in the Black Wall Tunnel Refineries with his responsibilities being in energy management (i.e. savings, operation, policy). He also worked as a Lab Manager in the South Bank University School of Engineering. He served as Assistant Professor in Azad University (Iran) and presently is serving as Vice Chancellor for research in Mashhad Azad University (Iran).



Mahdi Fahiminaw was born in 1984. He was admitted in Mechanical engineering (Fluid Mechanics) at Mashhad Azad University (Iran), in 2003. In 2007, he graduated as the top student. His research is diversified in the areas of theoretical and numerical modeling of natural convection heat transfer and electronic cooling... He started to study M. Sc. in Mechanical Engineering at IAUM in 2008, he has more than 6 dissertations in National & International Conferences and also 4 Iranian Journals.



Mohammad Mahdi Naserian was born in 1986. He was admitted in Mechanical engineering (Solid Mechanics) at Mashhad Azad University (Iran), in 2004. In 2008, he graduated as the top student. His research is diversified in the areas of theoretical and numerical modeling of natural convection heat transfer and electronic cooling... He started to study M. Sc. in Mechanical Engineering at IAUM in 2008. He has more than 6 dissertations in National & International Conferences and also 4 Iranian Journals.