

Network Mobility Support in Content-Centric Internet

Zhiwei Yan, Jong-Hyouk Lee, Yong-Jin Park, Xiaodong Lee

Abstract—In this paper, we analyze Network MOBility (NEMO) supporting problems in Content-Centric Networking (CCN), and propose the CCN-NEMO which can well support the deployment of the content-centric paradigm in large-scale mobile Internet. The CCN-NEMO extends the signaling message of the basic CCN protocol, to support the mobility discovery and fast trigger of Interest re-issuing during the network mobility. Besides, the Mobile Router (MR) is extended to optimize the content searching and relaying in the local subnet. These features can be employed by the nested NEMO to maximize the advantages of content retrieving with CCN. Based on the analysis, we compare the performance on handover latency between the basic CCN and our proposed CCN-NEMO. The results show that our scheme can facilitate the content-retrieving in the NEMO scenario with improved performance.

Keywords—CCN, handover, NEMO, mobility management.

I. INTRODUCTION

THERE is a growing interest in deploying high-speed wireless LANs (WLAN) on public transport vehicles to allow travelers to connect their devices to the Internet. Such an on-board mobile network (NEMO) typically consists of a high-speed mobile LAN and a Mobile Router (MR) which provides connectivity to the Internet through wireless links (e.g. WLAN, WiMAX or 4G). A mobile network may attach inside another one and the aggregated hierarchy of mobile networks is called a nested mobile network. The nodes inside the mobile network are generally called Mobile Network Node (MNN).

In order to support the network mobility in the IPv6 architecture, the NEMO basic supporting protocol (NEMO-BSP) [1] was designed based on the basic Mobile IPv6 (MIPv6) [2]. However, the NEMO-BSP suffers from all the shortcomings of MIPv6, such as the heavy signaling cost and long handover latency. Besides, some particular problems arise according to the NEMO-BSP, such as the sub-optimized routing and high overhead for the packet transmission in the nested case. Then the Proxy Mobile IPv6 (PMIPv6) [3] based NEMO solutions were proposed after the efficient PMIPv6 was standardized. While, the PMIPv6 based proposals are still under study and none of them has been standardized until now.

Although there are many researches about the NEMO and its related extensions, most of them are based on the IP protocols. And the security, scalability and efficiency shortcomings of the IP Internet are of course inherited in those NEMO extensions.

Z. W. Yan and X. D. Lee Yan are with China Internet Network Information Center, Beijing, P. R. China (e-mail: yanzhiwei@cnnic.cn, xl@cnnic.cn).

J.-H. Lee is with Department of Computer Science and Engineering, Sangmyung University, Seoul, Korea (e-mail: jonghyouk@smu.ac.kr).

Y.-J. Park is with Department of Communications and Computer Engineering, School of Fundamental Science, Waseda University, Tokyo, Japan (e-mail: yjp@ieee.org).

In order to effectively solve these problems of the current Internet and make it more suitable for the future applications, the concept of Information-Centric Networking (ICN) [4], [5] was proposed and the Content-Centric Networking (CCN) [6] is one of the most important representatives among the ICN proposals. In CCN, the communication is consumer-initiated and a consumer retrieves an individual content object by sending an Interest that specifies the name of the desired content object. Based on this basic principle, many extensions are proposed to support its deployment in the mobile Internet. However, the NEMO supporting scheme is still in the air and that is just the motivation of this paper.

Although the basic CCN routing scheme supports the receiver mobility in nature by the re-issuing of Interest after the handover, the location change may be transparent for the MNNs in NEMO. So in the proposed scheme of this paper, the CCN signaling message is extended to support the mobility discovery and trigger the Interest re-issuing when the entire subnet moves. Besides, the MR functions are extended to support the optimized content retrieving and relaying in the local subnet and this can be supported even in the nested NEMO case.

The remainder of this paper is organized as follows: Firstly, we present the NEMO concept in the MIPv6 environment. Secondly, we introduce our scheme in detail. After the performance analyzing, the concluding remarks are given as the last part.

II. RELATED WORK

A. Network Mobility in MIPv6 Network

Based on the MIPv6, the NEMO-BSP was proposed to provide the network mobility in the MIPv6 environment. In NEMO-BSP, the MR manages the movement of the entire mobile network and provides continuous and uninterrupted Internet access to the MNN. The MR combines MIPv6 MN functionality with basic Access Router (AR) functionality and manages the delivery of packets to and from the mobile network. Home Agent (HA) is a mobility anchor point which assists MR by keeping track of the current point of network attachment, also known as Care-of Address (CoA) of MR and delivering packets destined to the Mobile Network Prefix (MNP) to the current CoA of MR.

When the MR moves away from its home network, it acquires a CoA as the MN does in MIPv6. To set up a bidirectional tunnel with the HA, the MR first sends a Binding Update (BU) message to the HA and the HA then replies with a Binding Acknowledgement (BA) message. The bidirectional tunnel between the HA and the MR have endpoints with the address of the HA on one end and the CoA of the MR on the other end. When a packet is originated from a Corresponding

Node (CN), it is sent through this tunnel. The MR then decapsulates this packet and forwards it to the MNN. Similarly, the packet is encapsulated at the MR and decapsulated by the HA when it is originated from a MNN. According to this basic principle, the nested-tunnels will be used when the MR attaches to another MR in a nested manner and packet transmission will be inefficient. The root reason of this disadvantage is the communication model in the IP network.

B. CCN and Its Mobility Support Extensions

The CCN changes the communication model in the IP network and it is shown in Fig. 1. Requests (Interest packets) for some content are forwarded toward a publisher location. A CCN router maintains a Pending Interest Table (PIT) for outstanding forwarded requests, which enables request aggregation. That means a CCN router would normally not forward a second request for a specific content when it has recently sent a request for that particular content. The PIT maintains state for all Interests and maps them to network interface where corresponding requests have been received from. Data is then routed back on the reverse path using this state.

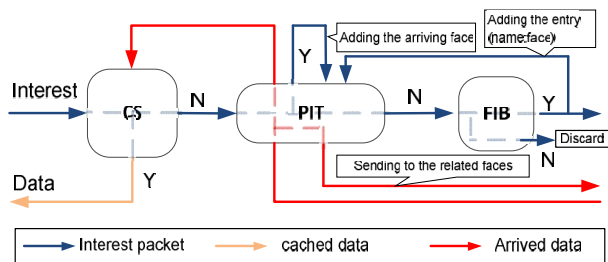

Fig. 1 CCN communication model

CCN supports on-path caching: contents received by a CCN router (in responses to requests) can be cached in the Content Store (CS) so that subsequent received requests for the same object can be answered from that cache. If the Interest cannot be consumed by the CS and has no match entry in the PIT, the router will send it out according to the Forwarding Information Base (FIB), which is maintained as the routing table in the IP network. Based on this basic communication model, many extensions in the mobile environment are studied and developed recently. For example, there are some works about the receiver mobility [7], source mobility [8], MANET support [9] and V2V support [10] in the CCN. Although the CCN can support the mobility in nature due to its connectivity-less feature (the mobile receiver only needs to re-issue the Interests at the new location), the NEMO will pose new challenge because the MR mobility is transparent to the MNN. In this way, the MNN based on the basic CCN will re-issue the pending Interests only after the Interest timeout and which will induce extra handover latency and discounted user experience. Then we propose a NEMO protocol based on CCN in this paper for efficient content retrieving.

III. CCN-NEMO

A. Problem statement

The possible NEMO scenarios are illustrated in Fig. 2. There are some problems have to be solved if the NEMO supporting is based on the basic CCN protocol.

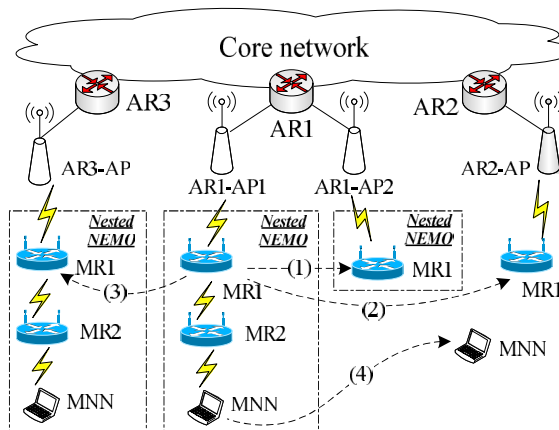

Fig. 2 Basic CCN based NEMO

- 1) When the handover of MR happens between different access points but under the same access router, the MNN still re-issues the pending Interests unnecessarily. For example, when the MR1 moves from AR1-API to AR1-AP2 (case 1 in Fig. 2) together with the whole subnet, the pending Interests will be duplicated to the AR1 and cause extra signaling cost.
- 2) In the nested NEMO scenario, the upper-layer MR will continually retrieve the Data corresponding to the pending Interests, although the related MNN/MR has left due to the reorganized NEMO structure. For example, when the MR1 hands over from AR1 to AR2 alone (case 2 in Fig. 2), it will still maintain the pending Interests. However, the MR2 and MNN may move to other places and then the PIT cannot be updated timely.
- 3) If the nested level is large and the wireless condition is bad, some Interests may be lost during the transmission especially when the handover happens frequently. For example, the fast moving MR1 hands over from AR1 to AR3 (case 3 in Fig. 2), the Interests sent by the MNN may be lost along the unstable wireless links. Then the MNN can only re-issue the Interests after the timeout because the movement of the MR is transparent to it.
- 4) The MNN may be involved in some delay-sensitive services and then the path (location) information is needed to support its mobility management. For example, the MNN may be involved in an audio/video chat or providing/receiving some real-time multimedia content during its movement (case 4 in Fig. 2), a seamless handover solution is needed in order to guarantee the user experience. According to the current researches of the mobility management in CCN, the identification of the access router is necessary and it is better to be a

hierarchical structure to follow the CCN routing scheme. Some examples include the Indirection Point based solution [8], Tunnel-based Redirection solution [11], Interest Forwarding based solution [12] and Interest Forwarding + Indirection Point based solution [13].

Based on the above considerations, we propose the CCN-NEMO which is inherited from the basic CCN protocol with the extended signaling message and FIB/PIT management scheme. The MR/AR is an extended CCN router to broadcast this signaling message for the mobility discovery in the local subnet. Besides, the MR maintains the default route in the FIB to transmit the local traffic to the upstream router. In this way, the PIT and CS in the MR can also be used for the content retrieving in the local subnet to improve the data addressing performance.

B. Extended Signaling Message

The signaling message herein is used for the mobility discovery in the local wireless subnet. We do not specify its format in this paper; however, the mandatory information should have the identification of the upper-layer router and the related lifetime. If this signaling message is extended from CCN Announcement message, the prefix part should be also generated as a CCN hierarchical name. For example, the domain part is "location-ws", which identifies that this name is used as the location identification in the wireless scenario. For an AR, the format of its identification name is

/location-ws/AR

In this way, the attached MR which receives it can establish a default route in its FIB as

/ → /location-ws/AR → Face

It means all the Interests which cannot be satisfied in the local subnet should be transmitted to the AR's interface. In this way, the FIB should be extended with an index section (the identification or path information) based on the basic CCN protocol.

For the MR, it is an extended AR and then this kind of signaling message has to be periodically sent out with the following identification information

/location-ws/AR/MR

In order to construct the above identification (or path) information, the MR only needs to attach its identification to the received one.

In order to reduce the signaling cost caused by periodically broadcast of the above signaling message by the MR/AR, we here propose that a 1-bit flag can be added in the above signaling message to support the passive broadcast of path information and this 1-bit flag is denoted as "M". When the MR hands over to a new location or discovers its mobility, the signaling message is sent out and the value of this 1-bit binary "M" is calculated as

$M=0b(M+1)$

Besides, the MR/MNN records the "M" flag together with the identification information as

M: /location-ws/AR/MR

When the signaling message is received, the MR/MNN only needs to compare the "M" flag when no detachment happens and then decide whether the handover happened in the upper level. For the MR, it also needs to modify its "M" flag and immediately broadcasts the modified signaling message in its subnet if the received "M" is different from the recorded one. This identification information is also attached in the Interest message sent out by the MR/MNN. In this way, the upper-layer MR/AR can establish the index of the PIT entries as shown in following format

Content-name → /location-ws/AR/MR → Face

Besides, when the MR/MNN moves between different access points under the same access router, it will send a blank Interest to the MR/AR (recorded in the default route) with its identification information. Then the upper-layer MR/AR can easily recognize that the MR/MNN moves only between access points and then changes the face of the PIT entries to the new access point related direction.

Based on the CCN naming structure, we can easily identify the network topology and help the MR/MNN to know its accurate location and maintain the up-to-date default route with this index. Besides, the MR/AR can manage the PIT more accurately.

C. Mobility Discovery

When the MR receives the signaling message above, it will extract the path information from it firstly. Then the MR compares the path information with its default route index. If the match is positive, no operation is needed because it means the connected AR or MR does not change. If the match is negative, the MR firstly updates its default route in the FIB. Then it should reconstruct the signaling message with the new path information based on the received one.

When the MNN receives the signaling message with different path information, it recognizes that the subnet has moved as a whole or it hands over to a new MR/AR.

D. Interest Re-Issuing

Based on the mobility discovery scheme above, two kinds of Interest re-issuing policy can be adopted:

MNN-based: the MNN should have the functionality for the mobility discovery and then re-send the pending Interests accordingly. In this way, the MR only needs to re-retrieve the Data corresponding to the currently attached MNN. Because we use the identification information in the Interest and introduce the blank Interest to announce the live state of the MR/MNN, the congestion can be reduced because the MNN do not need to re-issue all the pending Interests again but only need a single Interest to notify its existence to the attached MR.

Based on the analysis in the problem statement, this policy is suitable for the dynamic case in which the MNN handover is frequent and the network condition is bad.

MR-based: the MR maintains the PIT when the MNN sent the Interests. Then the MR can re-send all the Interests based on the PIT records when the handover is discovered. In this way, the network mobility is still transparent to the MNN. Besides, the Interests can be aggregated further in this mode which can reduce the cost in the local subnet caused by the MNN-based announcement in the above case. However, the MR will retrieve all the Data in the PIT and some of them may not be needed because the related MNN may have left at that moment and then the extra cost is induced. Based on the analysis in the problem statement, this policy is suitable for the stable case in which the MNN handover is infrequent and the network condition is good.

E. Data Routing

When the MR receives the Interest packet from MNN, it firstly checks its CS and PIT to find whether there is matched data. If yes, the Interest can be satisfied immediately. If no, the MR will send the Interest to the face maintained in the FIB and then a PIT entry is established. That means our scheme inherits the basic CCN routing scheme and then the extensions on the MR will be minimized. Although the local searching from both directions in the nested NEMO case may optimize the content retrieval, it will make the protocol more complex because the tuning between local searching and normal addressing should be carefully designed and the extra operations of MR will be needed. So we only consider the upward check in this paper.

F. Handover Procedure

The handover procedure is illustrated in Fig. 3.

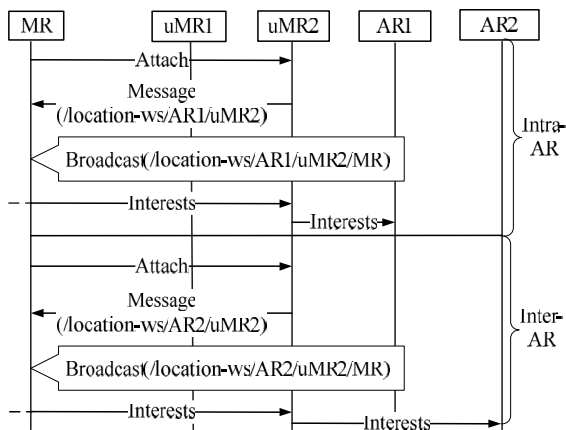

Fig. 3 Handover procedure of CCN-NEMO

In the intra-AR scenario, the MR moves between uMR1 and uMR2 (uMR means upper-layer MR), and they are located under the same AR (e.g., AR1). While, in the inter-AR scenario, the MR moves from uMR1 to uMR2, and they are located under different ARs (e.g., uMR1 and uMR2 are located at AR1 and AR2 separately). We use the basic signaling message in the following and the “M” flag is not considered

because it is only introduced to reduce the signaling cost during the mobility discovery. Besides, the MNN-based Interest re-issuing policy is adopted as an example.

- 1) The handover procedure of intra-AR is listed as follows: Before handover, the MR’s default route in the FIB is

$/ \rightarrow /location-ws/AR1/uMR1 \rightarrow Face1$

Besides, the signaling message broadcasted by the MR in its subnet contains the path information as

$/location-ws/AR1/uMR1/MR$

When MR moves from uMR1 to uMR2, the MR receives the signaling message from the uMR2 and the path information in this signaling message is

$/location-ws/AR1/uMR2$

After the comparison between this path information and the recorded one, the MR recognizes that the upper level access router changes from uMR1 to uMR2. Then the MR updates its default route in the FIB as

$/ \rightarrow /location-ws/AR1/uMR2 \rightarrow Face2$

We assume that the interface attaching to the uMR2 is Face2. Besides, the MR sends a signaling message to its subnet and the included path information is

$/location-ws/AR1/uMR2/MR$

Because MNN finds that the path information has changed but it still resides under the same MR, it will send a blank Interest to announce its existence and do not wait the pending Interests timeout according to the MNN-based policy. In this way, the MR will re-issue the related pending Interests corresponding to this MNN and send them to the new default face (e.g., uMR2) as soon as possible. Then the uMR2 checks its CS and sends out the unmatched Interests to the AR1. Because the AR1 is the branching node of uMR1 and uMR2, it can immediately serve these Interests with the cached data.

- 2) The handover procedure of inter-AR is listed as follows: Before handover, the MR’s default route in the FIB is

$/ \rightarrow /location-ws/AR1/uMR1 \rightarrow Face1$

Besides, the signaling message broadcasted by the MR in its subnet contains the path information as

$/location-ws/AR1/uMR1/MR$

When MR moves from uMR1 to uMR2, the MR receives the signaling message from the uMR2 and the path information in this signaling message is

$/location-ws/AR2/uMR2$

After the comparison between this path information and the recorded one, the MR recognizes that the first-hop access router changes from uMR1 to uMR2 and the second-hop access router changes from AR1 to AR2. Then the MR updates its default route in the FIB as

$$/ \rightarrow /location-ws/AR2/uMR2 \rightarrow Face2$$

We assume that the interface attaching to the uMR2 is Face2. Besides, the MR sends a signaling message to its subnet and the included path information is

$$/location-ws/AR2/uMR2/MR$$

Likewise, MNN will send a blank Interest to announce its existence and the re-issued Interests are transmitted from MR to the uMR2 as soon as possible. The uMR2 checks its CS and sends out the unmatched Interests to the AR2. And the AR2 also checks its CS and then routes the unmatched Interests as in the normal case.

IV. ANALYSIS

In this section, we study the nested CCN-NEMO to analyze its handover latency and compare it with the basic CCN case. Because the handover latency will be different under different Interest re-issuing policies, we here only use the MNN-based policy as the worst case of CCN-NEMO (from the aspect of handover latency).

A. Network Model

We adopt the network model for our analysis as shown in Fig. 4. In terms of AR and MR locations, we assume that the total number of MRs within an AR is N and these MRs are located in the binary tree architecture with nested level as $n = \log_2(N+1)$. For example, let's assume that there are 15 MRs, and then the hierarchy level (n) is determined as 4.

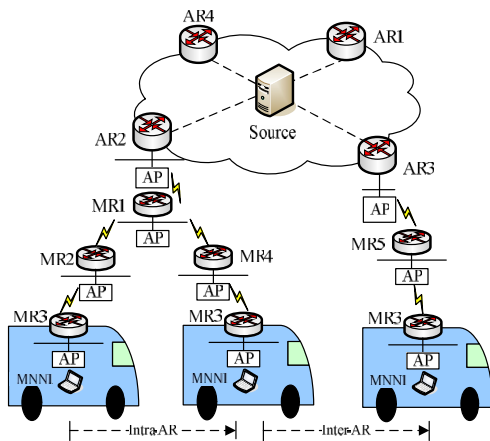

Fig. 4 The network model

We assume that a MR carrying the MNNs resides in a lowest level MR for a period and moves to the neighbor subnet. This is reasonable for the car or train as shown in Fig. 4 and the

residence time of MR in a subnet has Gamma distribution with mean $E(T_r) = 1/\lambda_p$ and variance ν [14]. Table I lists the values of the used parameters [14], [15]. T is the simulation duration, L is the timeout latency of the Interest packets. T_1 and L_2 denote the one-hop wire-line transmission latency and link-layer handover latency, respectively. h is the hops between AR and Source, T_c is the lifetime of the CCN cache.

TABLE I
PARAMETER SETTINGS

Parameter	Value	Parameter	Value
$1/\lambda_p$	30s	T	500s
L	100ms	T_1	100ms
L_2	200ms	ν	$10/\lambda_p^2$
h	2~10(default 6)	T_c	800ms

B. Handover Latency

We reasonably assume that the value of L is much smaller than the MR/AR subnet residence time and then the shortest handover latency (the duration between the last Data receiving moment in the previous subnet and the first Data arriving moment in the new subnet) of the proposed scheme is

$$H_p = L_2 + 7 \times T_1 + 2X \times T_1 \quad (1)$$

After the link-layer handover (the latency is L_2), the MR will ask for the new path information because it recognizes the handover (the latency is $2 \times T_1$). Because the recorded path is different from the received one, the MR immediately generates its new path information and broadcasts it in the local subnet (the latency is $1 \times T_1$). This will trigger the blank Interest issuing of the MNN and then the Interests will be transmitted from its attached MR to the new upper-layer MR (the latency is $2 \times T_1$). The new upper-layer MR also sends the Interest to its up-streaming MR until they arrive at the branching point between the previous upper-layer MR and this new upper-layer MR (the latency is $X \times T_1$). Because the branching node may cache the received data and then can consume the Interests immediately, the data returning time is $X \times T_1 + 2 \times T_1$. In the above analysis, X denotes the hops to arrive at the branching node and it is decided by the old and new locations of the MR.

While, if the above handover latency is too long, the branching node may delete that out-of-date cache data and then the MRs and AR have to request that data from the potential Source as the request for the first time. We use H here to denote the latency from the handover moment to the arriving moment of the re-issued Interest at the branching node. And then the average handover latency is

$$P(H < T_c) \times H_p + P(H > T_c) \times [H_p + 2(n - X + h) \times T_1] \quad (2)$$

where $H = L_2 + 5 \times T_1 + X \times T_1$. Besides, $2(n - X + h) \times T$ denotes the latency for the data retrieval from the branching node to the Source.

In the basic CCN case, the MNN may re-issue the Interests until they are timeout. And then its handover latency in the best case is prolonged by L . Then its average handover latency is

$$P[(H + L) < T_c] \times (H_p + L) + P[(H + L) > T_c] \times [H_p + L + 2(n - X + h) \times T_1] \quad (3)$$

C. Numerical results

Fig. 5 shows the handover latency of CCN-NEMO and the basic CCN as the function of hops between the AR and the CCN Source. Due to the active mobility discovery in the CCN-NEMO, the handover latency can be effectively reduced. The prolonged handover latency based on the basic CCN causes the timeout of the cached data at the branching node with higher possibility and then the MRs and AR have to fetch the data again from the core network and may be from the Source. And then the user experience will be degraded further.

Fig. 6 shows the handover latency of the proposed CCN-NEMO and the basic CCN under different timer settings. The timer of the Interest has no influence on the CCN-NEMO because the Interest re-issuing in CCN-NEMO is triggered actively. However, with the increased value of cache timer, the re-issued Interests may be satisfied by the branching node with higher possibility. And then the handover in CCN-NEMO can be reduced significantly. However, the handover latency of basic CCN is higher than that of CCN-NEMO under any condition due to the passive re-issuing of pending Interests. In addition, the CCN-NEMO with MR-based Interest re-issuing policy will be more efficient on the aspect of handover latency because it can avoid the one-hop wireless transmission from MNN to the MR. When the cache timer is 0.9s, the handover latency of CCN can be reduced about 1s if the timer of Interest is smaller than 0.3s because the cache in branching node can be used in this case. In other cases, the long handover latency induces the re-fetching from the Source and then the latency under different cache timers is identical.

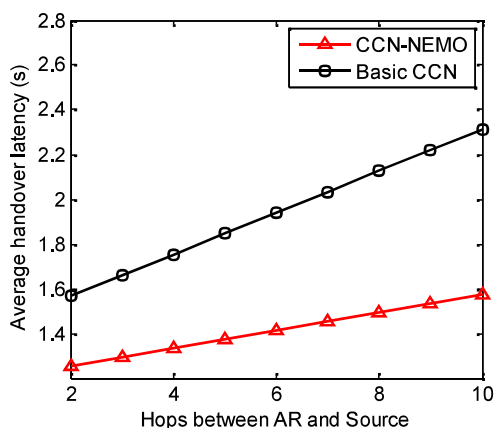

Fig. 5 Handover latency as the function of hops between AR and Source

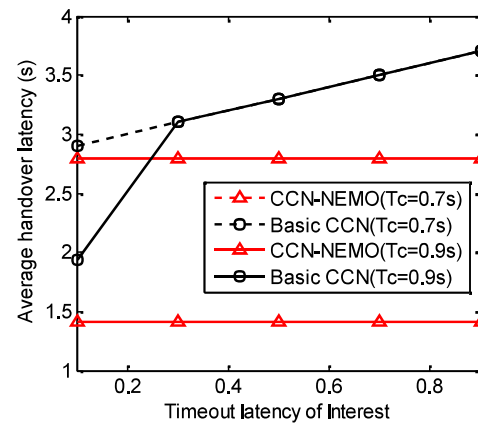

Fig. 6 Handover latency as the function of timers

V. CONCLUSION

In this paper, we propose an efficient NEMO supporting scheme in the content-centric Internet. Based on the extended signaling message, the MR/MNN in the NEMO can immediately recognize the mobility of the upper-layer MR and trigger the re-transmission of pending Interests. In this way, the MNN can receive the Data packets as soon as possible after the handover. The functionality of the MR is extended based on the basic CCN router to establish and maintain the default FIB routing entry on one hand, and to search the Data in the local subnet and identify its path information on the other hand. Then we setup an analytical scenario and analyze the performance of the proposed CCN-NEMO and compare its worst case with the basic CCN scenario. The numerical results show that the proposed scheme inherits the high efficiency of basic CCN and improve the handover performance in the NEMO scenario. Such a feature would especially favor to next generation Internet with the increasing deployment of mobile network and large scale traffic of mobile network.

ACKNOWLEDGMENT

This paper was supported by the National Natural Science Foundation of China under Grant No. 61303242.

REFERENCES

- [1] V. Devarapalli, et al., Network Mobility (NEMO) Basic Support Protocol, IETF RFC 3963, January 2005.
- [2] D. Johnson, et al., Mobility Support in IPv6, RFC 6275, June 2011.
- [3] S. Gundavelli, et al., Proxy Mobile IPv6, IETF RFC5213, August 2008.
- [4] D. Trossen, M. Sarela, and K. Sollins, Arguments for an information-centric internetworking architecture, SIGCOMM Computer Communication Review, 40(2): 26-33, 2010.
- [5] B. Ahlgren, C. Dannowitz, C. Imbrenda, D. Kutscher, and B. Ohlman, A Survey of Information-Centric Networking (Draft), In Information-Centric Networking, Dagstuhl Seminar Proceedings, February 2011.
- [6] V. Jacobson, et al., Networking Named Content, Proc. CoNEXT, Rome, Italy, 2009.
- [7] G. Tyson, et al., A Survey of Mobility in Information-Centric Networks: Challenges and Research Directions, Proc. of ACM NoM, June 2012.
- [8] F. Hermans, et al., Mobile Sources in an Information-Centric Network with Hierarchical Names: An Indirection Approach, Proc. of the 7th Swedish National Computer Networking Workshop, June 2011.

- [9] M. Meisel, et.al., Listen First, Broadcast Later: Topology-Agnostic Forwarding Under High Dynamics, Proc. of Annual Conference of International Technology Alliance in Network and Information Science, September 2010.
- [10] L. Wang, et.al., Data naming in vehicle-to-vehicle communications, Proc. of the 1st Workshop on Emerging Design Choices in Name-Oriented Networking, NOMEN'12, Mar. 2012.
- [11] J. Lee, S. Cho and D. Kim, Device Mobility Management in Content-Centric Networking, IEEE Communications Magazine, 50(12):28-34, December 2012.
- [12] D. Kim, J. Kim, Y. Kim, H. Yoon, and I. Yeom, Mobility Support in Content Centric Networks, Proc. of ACM ICN 2012, August 2012.
- [13] D. Han, et.al., PMC: Publisher Mobility Support for Mobile Broadcasting in Content Centric Networks, in Proceedings of AsiaFI 2012 summer school, Kyoto, Japan, August 2012.
- [14] T. L. Sheu and B. C. Kuo, An analytical model of two-tier handoff mechanisms for a hierarchical NEMO system, Wireless Networks, 14(6): 795-802, 2008.
- [15] J. H. Lee, Z. W. Yan, and I. You, Enhancing QoS of Mobile Devices by a New Handover Process in PMIPv6 Networks, Wireless Personal Communications, 61(4): 591-602, December 2011.

Zhiwei Yan received his Ph.D. degree from the National Engineering Laboratory for the Next Generation Internet Interconnection Devices at Beijing Jiaotong University. He joined China Internet Network Information Center in 2011 and is currently an Associate Professor of the Chinese Academy of Sciences. Since April 2013, he has been an Invited Researcher at Waseda University, Japan. His research interests include mobility management and network security.