

Multirate Neural Control for AUV's Increased Situational Awareness during Diving Tasks Using Stochastic Model

Igor Astrov and Andrus Pedai

Abstract—This paper focuses on a critical component of the situational awareness (SA), the neural control of depth flight of an autonomous underwater vehicle (AUV). Constant depth flight is a challenging but important task for AUVs to achieve high level of autonomy under adverse conditions. With the SA strategy, we proposed a multirate neural control of an AUV trajectory for a nontrivial mid-small size AUV “r2D4” stochastic model. This control system has been demonstrated and evaluated by simulation of diving maneuvers using software package Simulink. From the simulation results it can be seen that the chosen AUV model is stable in the presence of noises, and also can be concluded that the proposed research technique will be useful for fast SA of similar AUV systems in real-time search-and-rescue operations.

Keywords—Autonomous underwater vehicles, multirate systems, neurocontrollers, situational awareness.

I. INTRODUCTION

SITUATION awareness has been formally defined as “the perception of elements in the environment within a volume of time and space, the comprehension of their meaning, and the projection of their status in the near future” [1]. As the term implies, situation awareness refers to awareness of the situation. Grammatically, situational awareness (SA) refers to awareness that only happens sometimes in certain situations.

SA has been recognized as a critical, yet often elusive, foundation for successful decision-making across a broad range of complex and dynamic systems, including emergency response and military command and control operations [2].

The term SA have become commonplace for the doctrine and tactics, and techniques in the U.S. Army [3]. SA is defined as “the ability to maintain a constant, clear mental picture of relevant information and the tactical situation including friendly and threat situations as well as terrain”. SA allows leaders to avoid surprise, make rapid decisions, and

choose when and where to conduct engagements, and achieve decisive outcomes.

In [4], a two stage flight control procedure using two adaptive neural networks for helicopter as small-scale unmanned aerial vehicle (UAV) model was proposed. The proposed control strategy has been verified by simulation of descending and landing maneuvers of helicopter using software package Simulink and demonstrated good performance for fast SA.

This paper concentrates on issues related to the area of [4], but demonstrates another field for application of these ideas, i.e., research technique using multirate control system modeling and simulation on the basis of state-space equations of motion of chosen stochastic model of the autonomous underwater vehicle (AUV) for fast SA.

The AUV provides the commander with a number of capabilities including:

- Enhanced SA.
- Target acquisition.
- Enhanced management capabilities (assessment of surface damage and visualization of blockage far and near).

Some conditions for conducting underwater reconnaissance with AUVs are as follows.

- Time is limited or information is required quickly.
- Threat conditions are known; also the risk of collisions with a rough-surfaced sea bottom is high.
- Sea bottom relief restricts approach by large-scale underwater vehicles.

A mid-small size AUV offers many advantages, including low cost, the ability to fly at constant depth levels within a narrow space and the unique diving characteristics.

The fundamental requirement for diving control is the knowledge of the depth under the sea surface, and a properly designed controller to govern the process.

Optimum values for PID (proportional–integral–derivative) controllers are derived via the simulations of an AUV “r2D4” motion based on the closed-loop vehicle dynamics [5].

The characteristics of an AUV motion depend on mode of maneuvering, forward speed, instantaneous attitude, and outside appendages such as measuring instruments. In addition, it is hard to model the system disturbances, cross-flow and the coupling effects. Due to these reasons, the neural network controllers are needed to control AUV motions.

Manuscript received August 13, 2010. This work was supported in part by the Ministry of Education and Research of Estonia under Project SF0140113As08.

I. Astrov is with the Department of Computer Control, Tallinn University of Technology, Tallinn 19086, Estonia (corresponding author to provide phone: 372-620-2113, fax: 372-620-2101; e-mail: igor.astrov@dcc.ttu.ee).

A. Pedai is with the Department of Computer Control, Tallinn University of Technology, Tallinn 19086, Estonia (e-mail: andrus.pedai@dcc.ttu.ee).

In this paper our research results in the study of depth controls of an AUV which make such SA task scenario as “go-search-find-return” possible are presented.

The contribution of the paper is twofold: to develop new schemes appropriate for SA enhancement by multirate neural control of an AUV trajectory in real-time search-and-rescue operations, and to present the results of diving maneuvers for chosen stochastic model of the AUV for fast SA in simulation form using the MATLAB/Simulink environment.

II. AUV MODEL

Consider the stochastic model using linear model of mid-small size AUV “r2D4” [5] in terms of a state variable representation as follows:

$$\dot{x}_1 = A_1 x_1 + B_1 u_1 + v_1 \quad (1)$$

$$y_1 = C_1 x_1 + w_1 \quad (2)$$

$$\dot{x}_2 = A_2 x_2 + B_2 u_2 + v_2 \quad (3)$$

$$y_2 = C_2 x_2 + w_2 \quad (4)$$

where

$$u_1 = (n_m \quad n_{v_f} \quad n_{v_r} \quad \delta_{e_l} \quad \delta_{e_r})^T, u_2 = (\delta_{p_r} \quad \delta_{e_r} \quad \delta_{e_l})^T,$$

$$x_1 = (u \quad w \quad q \quad \theta)^T, x_2 = (v \quad p \quad r \quad \phi)^T,$$

$u(m/s), v(m/s), w(m/s)$ are surge, sway and heave velocities;

$p(radn/s), q(radn/s), r(radn/s)$ are angular velocities of roll, pitch and yaw motions;

$n_m(rps), n_{v_f}(rps), n_{v_r}(rps)$ are numbers of revolutions per second of main, fore-vertical and rear-vertical thrusters;

$\delta_{p_r}(radn), \delta_{e_r}(radn), \delta_{e_l}(radn)$ are deflection angles of main thruster axis, right and left elevators;

$\phi(radn), \theta(radn)$ are roll and pitch displacements;

$$A_1 = \begin{bmatrix} -0.1465 & 0.0263 & 0 & -0.0006 \\ 0.0683 & -1.3658 & 3.8905 & 0.1900 \\ -0.0062 & -0.0132 & -1.2340 & -0.0832 \\ 0 & 0 & 1 & 0 \end{bmatrix},$$

$$B_1 = \begin{bmatrix} 0.0491 & 0 & 0 & 0 & 0 \\ 0 & 0.0112 & 0.0006 & 0.0679 & 0.0679 \\ 0 & -0.0029 & 0.0018 & -0.0979 & -0.0979 \\ 0 & 0 & 0 & 0 & 0 \end{bmatrix},$$

$$A_2 = \begin{bmatrix} -0.5266 & -0.0024 & -0.8046 & -0.0052 \\ -3.5308 & -4.7897 & 8.0281 & -10.5544 \\ -0.1472 & -0.0332 & -0.4068 & -0.0722 \\ 0 & 1 & 0 & 0 \end{bmatrix},$$

$$B_2 = \begin{bmatrix} -0.0335 & -0.0011 & 0.0011 \\ 0.0244 & -2.1704 & 2.1704 \\ 0.0486 & -0.0149 & 0.0149 \\ 0 & 0 & 0 \end{bmatrix},$$

$$C_1 = C_2 = \begin{bmatrix} 1 & 0 & 0 & 0 \\ 0 & 1 & 0 & 0 \\ 0 & 0 & 1 & 0 \\ 0 & 0 & 0 & 1 \end{bmatrix}.$$

In [6], the derivative of yaw displacement ψ of an AUV could be expressed as

$$\dot{\psi} = (q \sin(\phi) + r \cos(\phi)) / \cos(\theta) \quad (5)$$

Then, we have

$$\psi(\tau) = \int_0^{\tau} \dot{\psi}(t) dt + \psi(0) \quad (6)$$

III. MULTIRATE SUBSYSTEMS

Consider the stochastic continuous-time control system described by the state and output equations

$$\dot{x}(\tau) = Ax(\tau) + Bu(\tau) + v(\tau) \quad (7)$$

$$y(\tau) = Cx(\tau) + w(\tau) \quad (8)$$

where $x(\tau) \in R^n, u(\tau) \in R^m, y(\tau) \in R^p, v(\tau) \in R^n, w(\tau) \in R^p$ are the state, control input, output, noise of excitation of state and noise of measurement vectors, respectively.

In [7] it is offered the approach to design of decomposed multirate stochastic linear systems, which consist of naturally grouped entrance and target signals that are caused by their characteristic frequencies.

Setting $q(\tau) = T\lambda(\tau)$, where T is a nonsingular matrix, we see that (7)-(8) are transformed into the equations

$$\dot{z}_1(\tau) = \Lambda_1 z_1(\tau) + B_1 u(\tau) + T_1 v(\tau) \quad (9)$$

$$\dot{z}_2(\tau) = \Lambda_2 z_2(\tau) + B_2 u(\tau) + T_2 v(\tau) \quad (10)$$

$$y(\tau) = C_1 z_1(\tau) + C_2 z_2(\tau) + w(\tau) \quad (11)$$

where

$$|\lambda(\Lambda_1)| \langle \gamma_{s_{\max}}, |\lambda(\Lambda_2)| \rangle \gamma_{f_{\min}}.$$

Definition 1: A function with a large derivative, which is quickly decreasing, is said to be the “fast” function, a function with a small derivative, which is slowly decreasing, is said to be the “slow” function.

Consider the first time interval $0 < \tau_f \leq \tau_{fs}$. According to Definition 1, the variable z_1 can be considered as a “slow” function on this interval. Hence, assuming that $\dot{z}_1(\tau_f) = 0$, from (9), we see that

$$z_1(\tau_f) = -\Lambda_1^{-1} B_1 u(\tau_f) - \Lambda_1^{-1} T_1 v(\tau_f). \tag{12}$$

From (10)-(12), we find that the state equations for a “fast” subsystem may be written as

$$\dot{z}_f(\tau_f) = A_f z_f(\tau_f) + B_f u_f(\tau_f) + T_f v_f(\tau_f) \tag{13}$$

$$y_f(\tau_f) = C_f z_f(\tau_f) + D_f u_f(\tau_f) + w_f(\tau_f) \tag{14}$$

where

$$A_f = \Lambda_2, B_f = B_2, T_f = T_2, C_f = C_2,$$

$$D_f = -C_1 \Lambda_1^{-1} B_1, V_f = -C_1 \Lambda_1^{-1} T_1,$$

$$z_f(\tau_f) = z_2(\tau_f), u_f(\tau_f) = u(\tau_f), v_f(\tau_f) = v(\tau_f),$$

$$y_f(\tau_f) = y(\tau_f), w_f(\tau_f) = w(\tau_f) + V_f v(\tau_f).$$

Consider the second time interval $\tau_s > \tau_{fs}$. According to Definition 1, the variable z_2 can be considered as a “fast” function of time, achieving on this interval a steady meaning. Hence, assuming that $\dot{z}_2(\tau_s) = 0$, from (10), we find

$$z_2(\tau_s) = -\Lambda_2^{-1} B_2 u(\tau_s) - \Lambda_2^{-1} T_2 v(\tau_s). \tag{15}$$

From (9), (11) and (15), we find that the state equations for a “slow” subsystem may be written as

$$\dot{z}_s(\tau_s) = A_s z_s(\tau_s) + B_s u_s(\tau_s) + T_s v_s(\tau_s) \tag{16}$$

$$y_s(\tau_s) = C_s z_s(\tau_s) + D_s u_s(\tau_s) + w_s(\tau_s) \tag{17}$$

where

$$A_s = \Lambda_1, B_s = B_1, T_s = T_1, C_s = C_1,$$

$$D_s = -C_2 \Lambda_2^{-1} B_2, V_s = -C_2 \Lambda_2^{-1} T_2,$$

$$z_s(\tau_s) = z_1(\tau_s), u_s(\tau_s) = u(\tau_s), v_s(\tau_s) = v(\tau_s),$$

$$y_s(\tau_s) = y(\tau_s), w_s(\tau_s) = w(\tau_s) + V_s v(\tau_s).$$

The “fast”-subsystem dynamic (13)-(14) of system (1)-(2) is described by

$$A_{f_1} = \begin{bmatrix} -1.2650 & 0.2030 \\ -0.2030 & -1.2650 \end{bmatrix},$$

$$B_{f_1} = \begin{bmatrix} 0.0009 & -0.0041 & -0.0048 & 0.1614 & 0.1614 \\ -0.0075 & 0.0651 & -0.0356 & 2.0014 & 2.0014 \end{bmatrix},$$

$$T_{f_1} = \begin{bmatrix} 0.0184 & -0.9665 & -2.3187 & -0.2278 \\ -0.1529 & 0.6334 & -20.0041 & -1.3744 \end{bmatrix},$$

$$C_{f_1} = \begin{bmatrix} 0.0224 & 0.0015 \\ -0.9620 & 0.1087 \\ -0.0319 & -0.0494 \\ 0.0185 & 0.0421 \end{bmatrix},$$

$$D_{f_1} = \begin{bmatrix} 0.3376 & 0.0006 & 0.0007 & -0.0260 & -0.0260 \\ 0.0135 & 0.0025 & -0.0014 & 0.0801 & 0.0801 \\ -0.0003 & 0.0027 & -0.0016 & 0.0871 & 0.0871 \\ -0.0270 & -0.0377 & 0.0223 & -1.2286 & -1.2286 \end{bmatrix},$$

$$V_{f_1} = \begin{bmatrix} 6.8764 & 0.1440 & 0.3656 & -0.1913 \\ 0.2752 & 0.0141 & -0.8080 & -0.9964 \\ -0.0061 & 0.0088 & -0.8841 & -1.0620 \\ -0.5496 & -0.1374 & 12.4547 & 15.0195 \end{bmatrix}.$$

The “slow” subsystem (16)-(17) of system (1)-(2) is specified by

$$A_{s_1} = \begin{bmatrix} -0.1458 & 0 \\ 0 & -0.0706 \end{bmatrix},$$

$$B_{s_1} = \begin{bmatrix} -0.1961 & 0.0004 & -0.0008 & 0.0374 & 0.0374 \\ -0.0083 & -0.0055 & 0.0033 & -0.1798 & -0.1798 \end{bmatrix},$$

$$T_{s_1} = \begin{bmatrix} -3.9944 & -0.0814 & -0.4385 & -0.1607 \\ -0.1686 & -0.0220 & 1.8216 & 2.2049 \end{bmatrix},$$

$$C_{s_1} = \begin{bmatrix} -0.2497 & -0.0149 \\ -0.0072 & -0.0322 \\ 0.0032 & -0.0339 \\ -0.0218 & 0.4801 \end{bmatrix},$$

$$D_{s_1} = \begin{bmatrix} -1.4148e-005 & 0.0002 & -0.0002 & 0.0106 & 0.0106 \\ -0.0004 & 0.0008 & 0.0048 & -0.1922 & -0.1922 \\ 0.0003 & -0.0027 & 0.0016 & -0.0871 & -0.0871 \\ -0.0003 & 0.0022 & -0.0013 & 0.0709 & 0.0709 \end{bmatrix},$$

$$V_{s_1} = \begin{bmatrix} -0.0003 & -0.0140 & -0.1183 & -0.0093 \\ -0.0085 & 0.7073 & 2.4535 & 0.2203 \\ 0.0061 & -0.0088 & 0.8841 & 0.0620 \\ -0.0051 & 0.0132 & -0.7150 & -0.0497 \end{bmatrix}.$$

The constant matrices of the “fast” subsystem (13)-(14) of system (3)-(4) are given by

$$A_{f_2} = \begin{bmatrix} -2.3681 & 2.2258 \\ -2.2258 & -2.3681 \end{bmatrix},$$

$$B_{f_2} = \begin{bmatrix} 0.0907 & -0.6604 & 0.6604 \\ 0.1281 & 2.2581 & -2.2581 \end{bmatrix},$$

$$T_{f_2} = \begin{bmatrix} -0.6275 & 0.2958 & 1.2850 & -1.5942 \\ -1.0733 & -1.0565 & 2.4259 & -3.1388 \end{bmatrix},$$

$$C_{f_2} = \begin{bmatrix} 0.0032 & 0.0013 \\ 1.2011 & -0.6099 \\ 0.0098 & -0.0034 \\ -0.3978 & -0.1164 \end{bmatrix},$$

$$D_{f_2} = \begin{bmatrix} -0.3826 & -0.0017 & 0.0017 \\ -0.0510 & -0.0001 & 0.0001 \\ 0.2064 & -0.0012 & 0.0012 \\ 0.3075 & -0.0003 & 0.0003 \end{bmatrix},$$

$$V_{f_2} = \begin{bmatrix} 3.2336 & 0.0380 & -5.6632 & 0.0014 \\ 0.3745 & 0.0053 & -0.7935 & -0.0005 \\ -0.8582 & -0.0242 & 3.6674 & 0.0103 \\ -1.8951 & -0.0335 & 5.0381 & 0.0076 \end{bmatrix}.$$

In terms of (16)-(17) for system (3)-(4), the "slow"-subsystem matrices are

$$A_{s_2} = \begin{bmatrix} -0.1760 & 0 \\ 0 & -0.8109 \end{bmatrix},$$

$$B_{s_2} = \begin{bmatrix} 0.4195 & -0.0007 & 0.0007 \\ -0.2092 & 0.0096 & -0.0096 \end{bmatrix},$$

$$T_{s_2} = \begin{bmatrix} -2.4575 & -0.0462 & 6.9611 & 0.0120 \\ -2.7191 & 0.0395 & -6.1990 & -0.0551 \end{bmatrix},$$

$$C_{s_2} = \begin{bmatrix} -0.1826 & -0.2039 \\ -0.0231 & -0.0156 \\ 0.0788 & -0.0721 \\ 0.1311 & 0.0192 \end{bmatrix},$$

$$D_{s_2} = \begin{bmatrix} 0.0002 & 0.0019 & -0.0019 \\ 0.0510 & 0.0001 & -0.0001 \\ 0.0004 & 0.0010 & -0.0010 \\ -0.0199 & -0.2055 & 0.2055 \end{bmatrix},$$

$$V_{s_2} = \begin{bmatrix} -0.0013 & -0.0009 & 0.0029 & -0.0037 \\ -0.3745 & -0.0053 & 0.7935 & -0.9995 \\ -0.0032 & -0.0005 & 0.0069 & -0.0087 \\ 0.1586 & 0.0970 & -0.3498 & 0.4481 \end{bmatrix}.$$

IV. AUV ATTITUDE

The derivative of attitude vector $(x \ y \ z)^T$ for center of mass of an AUV can be described in a common way through next expression as indicated in [6]

$$\begin{bmatrix} \dot{x} \\ \dot{y} \\ \dot{z} \end{bmatrix} = \begin{bmatrix} j_{11} & j_{12} & j_{13} \\ j_{21} & j_{22} & j_{23} \\ j_{31} & j_{32} & j_{33} \end{bmatrix} \begin{bmatrix} u \\ v \\ w \end{bmatrix},$$

(18)

where

$$j_{11} = \cos(\psi)\cos(\theta),$$

$$j_{12} = -\sin(\psi)\cos(\phi) + \cos(\psi)\sin(\theta)\sin(\phi),$$

$$j_{13} = \sin(\psi)\sin(\phi) + \cos(\psi)\cos(\phi)\sin(\theta),$$

$$j_{21} = \sin(\psi)\cos(\theta),$$

$$j_{22} = \cos(\psi)\cos(\phi) + \sin(\phi)\sin(\theta)\sin(\psi),$$

$$j_{23} = -\cos(\psi)\sin(\phi) + \sin(\theta)\sin(\psi)\cos(\phi),$$

$$j_{31} = -\sin(\phi),$$

$$j_{32} = \cos(\theta)\sin(\phi),$$

$$j_{33} = \cos(\theta)\cos(\phi).$$

Then, we have

$$x(\tau) = \int_0^\tau \dot{x}(t)dt, \quad y(\tau) = \int_0^\tau \dot{y}(t)dt, \quad z(\tau) = \int_0^\tau \dot{z}(t)dt, \quad (19)$$

where $x(0) = 0, y(0) = 0, z(0) = 0$.

From (1)-(6), (18)-(19) we can see that the attitude vector $(x \ y \ z)^T$ for given model of the AUV can be computed.

V. SIMULATION RESULTS

Consider the control of the AUV "r2D4" decomposed multirate model for the case of hybrid control system with one neurocontroller.

The goal of the following simulations is twofold. First, we verify that this neurocontroller is able to control the diving trajectory. Second, we observed the effect of enhanced SA because the variety of such trajectory parameter as constant depth flight easily can be changed the possible diving trajectory of an AUV.

Initial conditions and desired constant depth level for multirate control subsystems are chosen to be:

$$x(0) = 0m, \quad y(0) = 0m, \quad z(0) = 0m, \quad z^0 = -25m.$$

Simulation results for the offered block scheme (see Fig. 1) are shown in Figs. 3-7.

In [8], the two approximations to the nonlinear autoregressive moving average (NARMA) model called the NARMA-L1 and the NARMA-L2 are proposed. From a practical stand-point, the NARMA-L2 model is found to be simpler to realize than the NARMA-L1 model. The

neurocontroller used in this section is based only on the NARMA-L2 approximate model.

The NARMA-L2 neurocontroller from Fig. 1 can be implemented in Fig. 2.

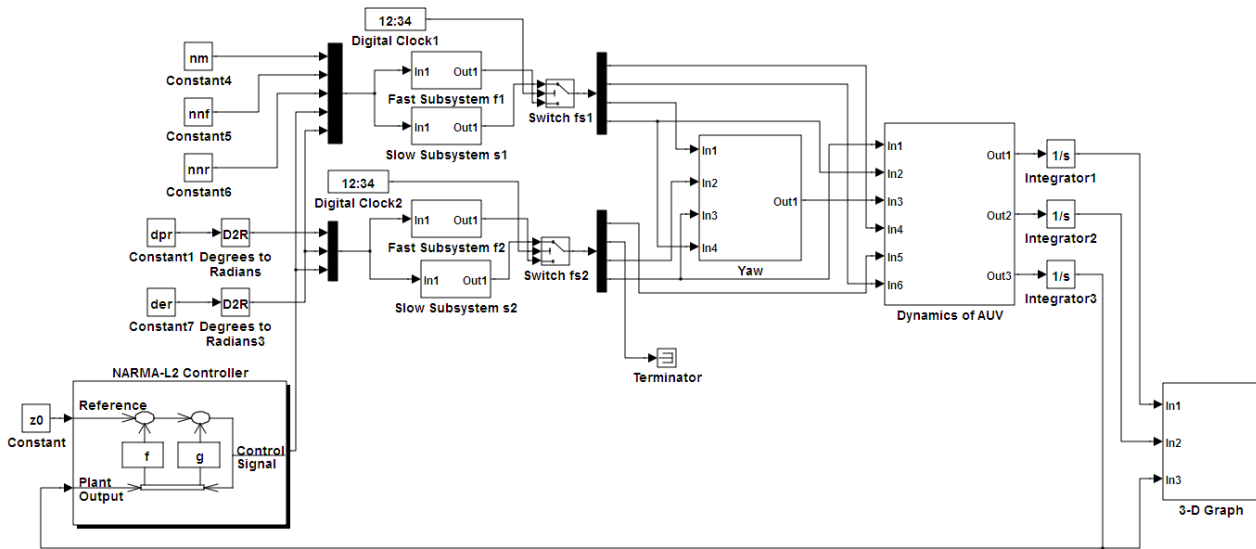

Fig. 1. Block diagram of hybrid control system.

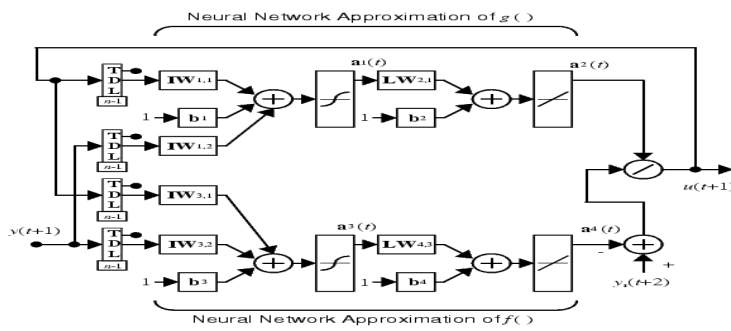

Fig. 2. Structure of a neural network representation for the NARMA-L2 approximate model.

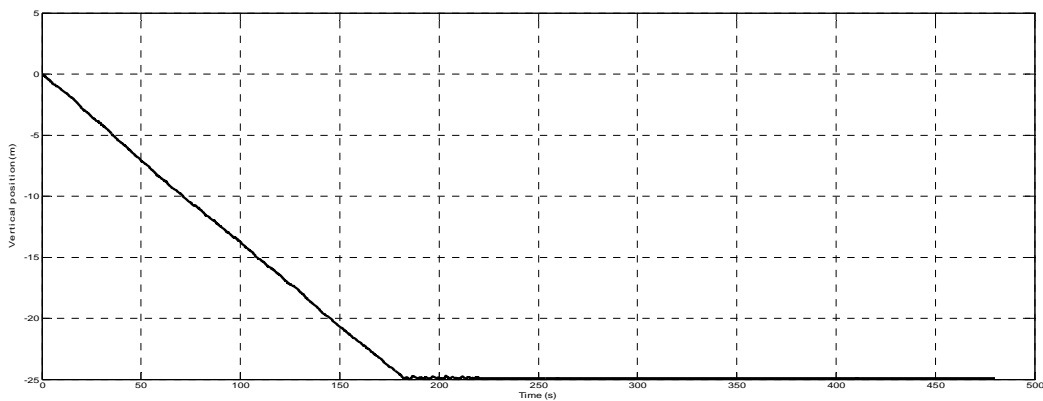

Fig. 3. AUV depth trajectory.

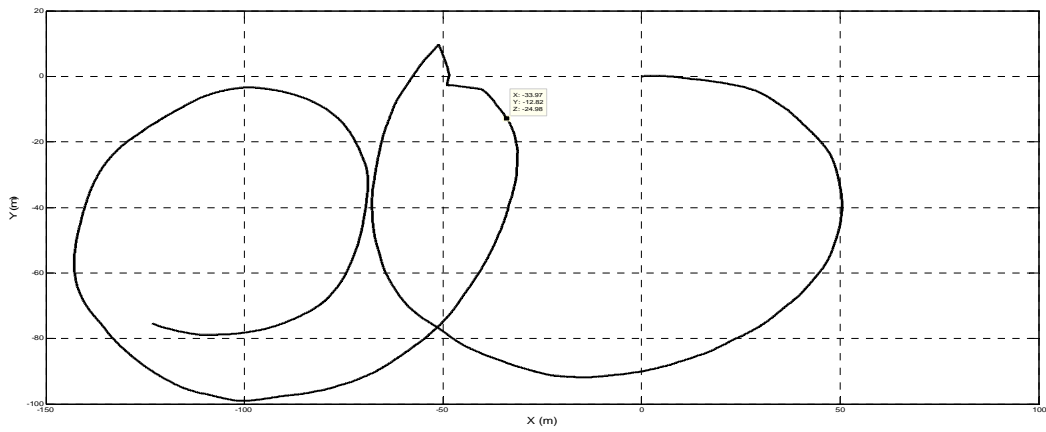

Fig. 4. X-Y view of AUV trajectory.

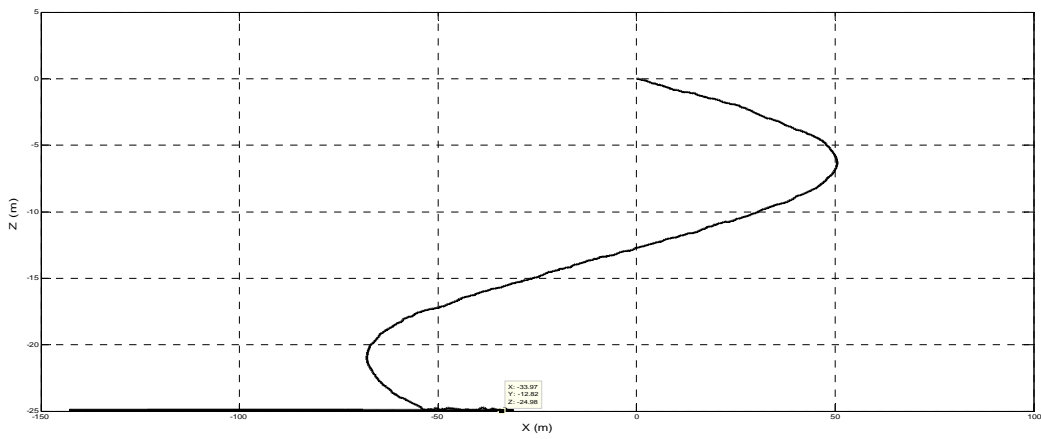

Fig. 5. X-Z view of AUV trajectory.

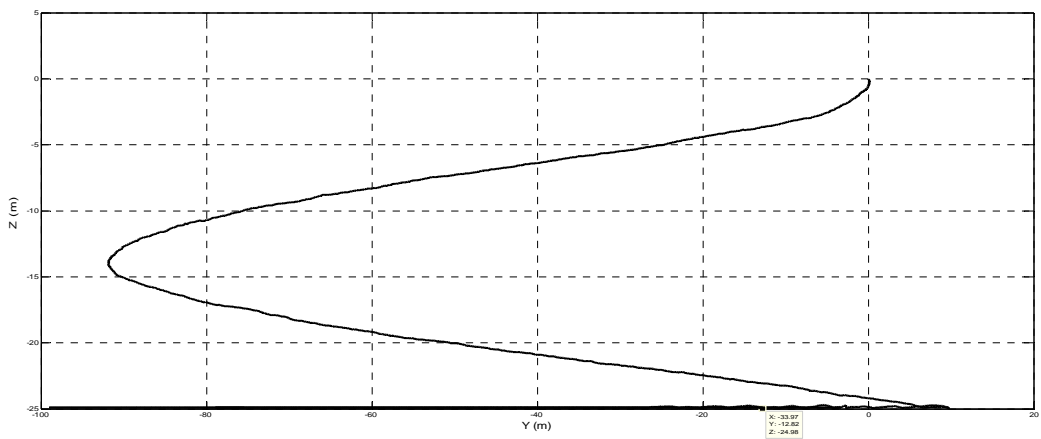

Fig. 6. Y-Z view of AUV trajectory.

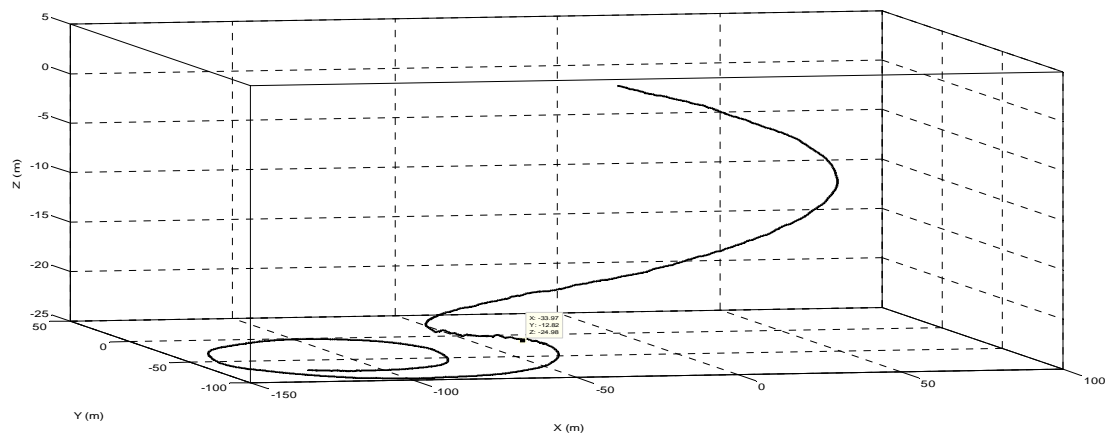

Fig. 7. 3-D motion of AUV.

From the simulation studies of diving tests, the following can be observed:

- By following the proposed methodology, the AUV “r2D4” model structure (1)-(4) is decomposed into two groups of subsystems: the “fast” subsystems used in the initial phase of trajectory (downward motion), and the “slow” subsystems used in the final phase of trajectory (approach motion). Note that the obtained subsystems not only have reduced dimensions of state-space matrices, but also various speeds of actuation (fast and long response times). Further analysis of the decomposed subsystems can be produced separately with the help of modern computer-aided control analysis software.

- Possibility to consider a rough-surfaced sea bottom in a place of a constant depth flight.

- Possibility of lag in the various constant depth levels.

- Fine and simplified adjustment of chosen adaptive neurocontroller for any changes of desired constant depths.

- The 3-D display forms give a researcher the view of an AUV “r2D4” motion with a range of such parameter as constant depth flight. This enhances the researcher’s understanding of diving maneuvers.

- The multirate control works more qualitatively than the single-rate control.

These results support the theoretical predictions well and demonstrate that this research technique would work in real-time diving conditions.

VI. CONCLUSIONS

The need for accurate and directionally stable diving for AUV class autonomous vehicles has increased morbidly for critical situations in real-time search-and-rescue operations with existence of system disturbances, cross-flow and the coupling effects for fast SA.

A new research technique is presented in this paper for enhanced SA in possible AUV missions. The effectiveness of this technique has been verified in field of diving simulation

tests for chosen model of the AUV “r2D4” using software package Simulink.

From the applications viewpoint, we believe that this depth multirate neural control using NARMA-L2 neurocontrollers furnish a powerful approach for enhancing SA in applications to AUV class autonomous vehicles in real-time search-and-rescue operations.

Although many of the details inevitably relate with this particular AUV model, there is sufficient generality for this research technique to be applied to similar AUV models for simulation of diving maneuvers.

Future work will involve further validation of the performance of the proposed research technique and exploring other relevant and interesting AUV missions.

REFERENCES

- [1] M. R. Endsley, “Toward a theory of situation awareness in dynamic systems,” *Human Factors*, vol. 37, pp. 32-64, March 1995.
- [2] J. Gorman, N. Cooke, and J. Winner, “Measuring team situation awareness in decentralized command and control environments,” *Ergonomics*, vol. 49, pp. 1312-1325, October 2006.
- [3] Interim Brigade Combat Team Newsletter. [Online]. Available: http://www.globalsecurity.org/military/library/report/call/call_01-18_toc.htm
- [4] I. Astrov and A. Pedai, “Enhancing situational awareness by means of hybrid adaptive neural control of vertical flight in unmanned helicopter,” in *Proc. International Conf. Control, Automation and Systems 2008*, Seoul, Korea, 2008, pp. 329-332.
- [5] T. Ura, T. Obara, K. Nagahashi, K. Kim, Y. Oyabu, T. Sakamaki, A. Asada, and H. Koyama, “Introduction to an AUV “r2D4” and its Kuroshima Knoll survey mission,” in *Proc. Conf. OCEANS '04. MTS/IEEE TECHNO-OCEAN '04*, Kobe, Japan, 2004, pp. 840-845.
- [6] J. H. Li and P. M. Lee, “Design of an adaptive nonlinear controller for depth control of an autonomous underwater vehicle,” *Ocean Engineering*, vol. 32, pp. 2165-2181, December 2005.
- [7] I. Astrov, A. Pedai, and E. Rüstern, “Simulation of two-rate adaptive hybrid control with neural and neuro-fuzzy networks for stochastic model of missile autopilot,” in *Proc. 5th World Congress on Intelligent Control and Automation*, Hangzhou, China, 2004, pp. 2603-2607.
- [8] K. S. Narendra and S. Mukhopadhyay, “Adaptive control using neural networks and approximate models,” *IEEE Trans. Neural Networks*, vol. 8, pp. 475-485, May 1997.