

# Modeling and Investigation of Elongation in Free Explosive Forming of Aluminum Alloy Plate

R. Alipour, F. Najarian

**Abstract**—Because of high ductility, aluminum alloys, have been widely used as an important base of metal forming industries. But the main weak point of these alloys is their low strength so in forming them with conventional methods like deep drawing, hydro forming, etc have been always faced with problems like fracture during of forming process. Because of this, recently using of explosive forming method for forming of these plates has been recommended. In this paper free explosive forming of A2024 aluminum alloy is numerically simulated and during it, explosion wave propagation process is studied. Consequences of this simulation can be effective in prediction of quality of production. These consequences are compared with an experimental test and show the superiority of this method to similar methods like hydro forming and deep drawing.

**Keywords**—free explosive forming, CEL, Johnson – cook

## I. INTRODUCTION

ALUMINUM weight is about 1/3 of steel in the same volume [2] so now a day's aluminum alloys has found wide application, as a substitute of steel, in industries like aerospace, automotive and military [1]. The most important weak point of aluminum, Compared with steel, is it's elasticity that causes fracturing during the forming. This problem is more seen during the forming by using usual method like hydro forming and deep drawing.

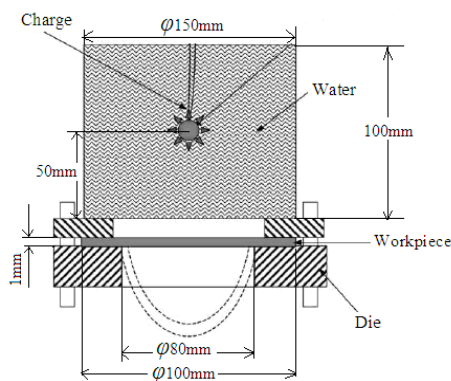

Fig.1 An explosive forming system schematic

So recently, free explosive forming method for forming

Roozbeh Alipour is with member of faculty of Islamic Azad University – Mahshahr branch, Iran, (Tel: +989166141452; e-mail: r.alipour@mahshahriau.ac.ir).

Farhad Najarian is an instructor in the Islamic Azad University – Saveh branch, Iran, (e-mail: Farhad\_najarian@yahoo.com.)

aluminum alloys has been in the center of attention [3, 4]. An explosive forming system schematic for aluminum parts production is shown Figure 1. As it is seen in this situation the blank is between to blank holder and above it there is a water tank.

Spherical explosive charge is above the blank in the water and in the distance called stand off. Explosive geometry and mass are chosen according to data in the in the references [5]. All measures for modeling of this process have been set according to experimental tests [6].

## II. PROCESS MODELING

### A. Modeling Method

According what is mentioned in references of this paper [7] Couple Eulerian Lagrangian (CEL) base on FEM, is the best possible way to model this process. So the mentioned model is used to this process. All the modeling and analyses steps are done by LS\_DYNA\_971 software.

### B. Explosive Modeling

The explosive used in the simulation of PETN which its properties are in table1 [6].  $P_{cj}$  and  $d_{cj}$  are the highest pressure and highest velocity produced by explosion of explosive base on Chapman-Jouguet respectively. Explosive geometry is considered spherical. To model the explosive in LS\_DYNA\_971 software the model of High\_Explosive\_Burn is used.

TABLE I  
PROPERTIES OF PETN MATERIALS

Charge Type	$\rho$ (kg/m <sup>3</sup> )	$D_{cj}$ (km/s)	$P_{cj}$ (Gpa)
PETN	1.763	8.274	31.5

### C. Water Modeling

The model of MAT\_NULL is used for water modeling in LS\_DYNA\_971 software that doesn't bear shear stress and seems convenient for fluid materials modeling [8]. In fact water as an energy transfer media with higher density, compared with air, plays the role as transmission material for transferring of explosion wave from charge to blank. Even though, there is around a tank around the water, but in this model instead of tank a rigid wall has been stretched around the elements of water.

D. Modeling of Aluminum Blank

Aluminum disk is consider of A2024 for description of range of effective stress rate on blank the Johnson – Cook equation has a lot of applications in the modeling of this problem by considering work hardening, strain rate, temperature variations, etc [9]. Formula 1 shows Johnson – Cook equation.

$$\sigma = (A + B\varepsilon^n)(1 + C \ln \dot{\varepsilon}_p)(1 - T^{*m}) \tag{1}$$

Where  $\varepsilon$  is equivalent plastic strain,  $\dot{\varepsilon}_p$  is plastic strain rate for  $\varepsilon_0 = 1$ , that T is absolute temperature for  $T^* = \frac{T - T_{room}}{T_{melt} - T_{room}}$  and

A, B, C, n and m are constant. Constants in this equations is obtained from simple mechanical tests such as isothermal tension and torsion tests, that is given in Table 2 for the materials used in this study.

TABLE II  
JOHNSON – COOKS CONSTANTS FOR ALUMINUM 2024

A (MPa)	B (MPa)	C (Mpa)	M	n	T <sub>melt</sub> (°K)
265	465	0.015	0.34	0.5	775

E. Equation of States

In addition to conservation essential equations including, mass conservation, linear and angular momentum conservation and energy conservation, in problems that are followed by intensive pressure, stress or volume variations there is a need to equation between thermodynamics properties (pressure, density and temperature). One of most applied equation of state for explosive is JWL<sup>1</sup> equation and Mie-Gruneisen for metal and water [10, 11].

Equation of JWL is in the form of equation 2.

$$P = C_1 \left(1 - \frac{\omega}{r_1}\right) e^{-r_1 v} + C_2 \left(1 - \frac{\omega}{r_2}\right) e^{-r_2 v} + \frac{\omega \psi}{V} \tag{2}$$

Where C<sub>1</sub>, C<sub>2</sub>, r<sub>1</sub>, r<sub>2</sub> and  $\omega$  are the constants of JWL equation. V is the ratio of the volume of the product gases to initial volume of undetonated explosive. The constant is given in Table 3 for the PETN [6] used in this investigation.

TABLE III  
JWL CONSTANTS OF PETAN

A(GPa)	B(GPa)	C(GPa)	R <sub>1</sub>	R <sub>2</sub>	$\omega$
1032.158	90.57014	3.72735	6	2.6	0.57

Equation of Mie-Gruneisen is in the form of equation 3.

$$P = \frac{\rho_0 C_0^2 \eta}{(1 - S\eta)^2} \left[ 1 - \frac{\Gamma_0 \eta}{2} \right] + \Gamma_0 \rho_0 E \tag{3}$$

Where  $\rho_0$  is initial density. E is internal energy.  $\Gamma_0$  is Gruneisen parameter.  $\eta = 1 - \rho / \rho_0$ , C<sub>0</sub> and S are material

constants. For the related materials, the values of those constants are given in table 4 [3, 12].

TABLE IV  
VALUES OF MIE - GRUNEISEN EQUASION CONSTANTS

MATERIAL	$\rho$ (kg/m <sup>3</sup> )	C <sub>0</sub> (m/s)	S	$\Gamma_0$
WATER	1000	1490	1.79	1.65
A2024	2770	3900	1.5	1.3

III. RESAULT AND DISCUSSION

A. Study of Shock Wave Propagation

Fig2 shows pressure contours of water elements. According to this figure a shock wave has been produced by explosion under the water in time between 5 $\mu$ s to 10 $\mu$ s and has started its spherical propagation. After 15 $\mu$ s, arrives in the middle of blank and the reflective wave is produces. This is completely visible after 20 $\mu$ s. The pressure produced by this wave rapidly drops at this moment. The wave produced by explosion cause the drawing the aluminium blank to 50mm depth. Forming of the blank goes to an end after 400 $\mu$ s.

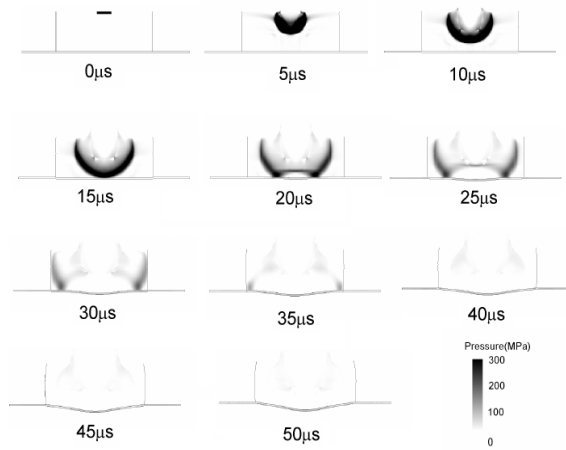

Fig.2 An explosive forming system schematic

B. Study of Forming Process

The rate of aluminium plate deformation was shown in fig3. The time in this figure is between "0 to 400 micro second". The curve related to this forming process was shown in fig4 as well. As it is obvious from fig3 and 4 the most deformation is between "10 to 25 micro second" and Strain rate became less after that the most available elongation. Using the explosive forming method; the maximum depth of drawing is 30.2, it is obvious from fig4.

<sup>1</sup> - Jones – Wilkins - lee

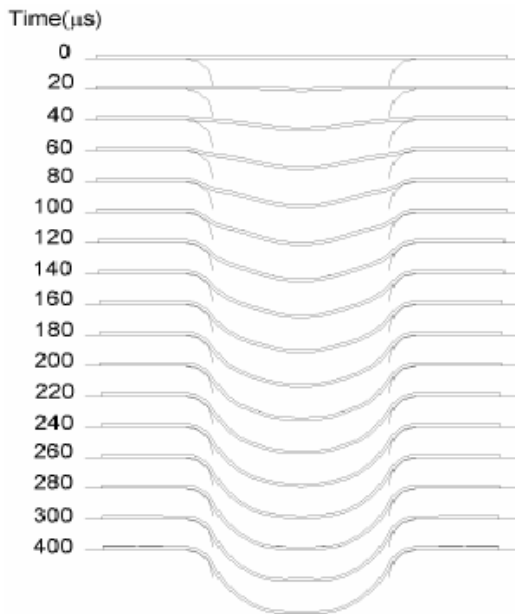

Fig. 3 The rate of aluminium plate deformation

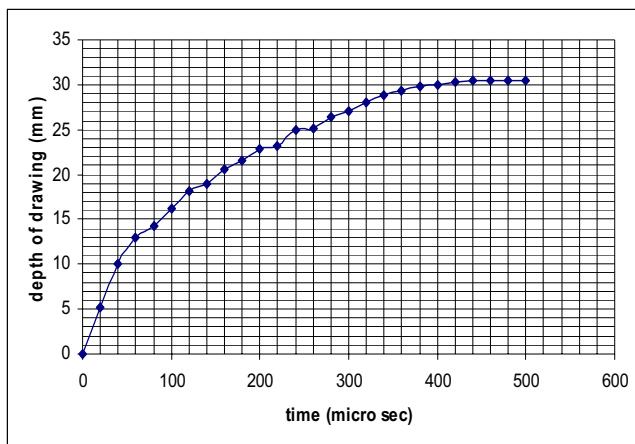

Fig. 4 The curve related to aluminium forming process

### C. Experimental and Theoretical Conclusions Comparison

The comparison between simulation and experimental conclusion was brought in table5

Method	Maximum depth of drawing
Deep drawing (experimental)	15.4 mm
Hydro forming (experimental)	19.1 mm
Explosive forming (experimental)	25.8mm
Explosive forming (numerical)	30.2 mm

According to that table the most elongation in hydro forming, deep drawing and explosive forming methods was studied and their conclusions of their simulation were

compared. In all mentioned in table5 test; plate materials A2024, the blank primary diameter 100mm, the die cavity diameter 80mm and the plate thickness in all models is 1mm. According to table5 information the most available elongation in hydro forming method had increase 24%, compared with deep drawing method. But this parameter had increasing in explosive forming method compared with deep drawing method 67% and hydro forming method 35%. The reason of this elongation increase in explosive forming methods compared with other methods can be mostly related to decreasing of friction effects, work hardening and increasing in effective strain rate. Although the error coming out of numerical methods in comparison with experimental method is 17%. That is ignorable according some factors in experimental methods such as spring back.

### IV. CONCLUSION

Available elongation in free explosive forming is more considerable in comparison with similar methods. The increase in elongation can happen because of following reasons: The live out friction effects between punch and work piece that doesn't exist in the explosive forming method. Because the mentioned factors lead to increase in she stress in aluminium plate and consequently precocious fracture. This effect goes down in hydro forming method because hydrostatic stress on plate. The decrease of work hardening and spring back effects due to high strain rate. Numerical methods in this article seem so trustable and affective because of low errors in comparison with experimental date.

### REFERENCES

- [1] D.J. Mynors, B. Zhang, "Applications and Capabilities of Explosive Forming", *Materials Processing Technology J.*, vol. 125-126, pp.1-25, 2002.
- [2] E. Paul Degarmo and others, "materials and processes of manufacturing", 3rd ed. McGraw-Hill, pp. 123-138, 2003.
- [3] A. A. Akbari Mousavi, G. Joodaki, "Explosive Welding Simulation of Multilayer Tubes", VIII conference of computational plasticity, 2005, Barcelona, Spain.
- [4] V.N. Wijayathunga, D.C. Webb, "Experimental evaluation and finite element simulation of explosive forming of a square cup from a brass plate assisted by a lead plug", *Materials Processing Technology J.*, vol.172, pp.139-145, 2006.
- [5] R. Alipour, D. Javabvar and A. Alavinia, "Numerical Simulation of Explosive Forming of Spherical Shells By Charge Geometry Variations", ISME Conf, 2008, Shahid Bahonar University, Kerman, Iran.
- [6] R. Alipour, "Simulation of explosive forming", M.sc Thesis in Mechanical Engineering, Islamic Azad university of Dezfoul, Iran, 2008, pp.56-86.
- [7] D. Javabvar, A. Alavinia, R. Alipour, "Investigation & Proffering a Suitable Numerical Method to Simulation of Non-Die Explosive Forming Problems", *energetic materials J.*, vol. 6, pp. 11-20, 2008.
- [8] LSTC. Ls\_Dyna, "Non-Linear Dynamic Analysis of Structures in Three Dimensions", Version 971, Theoretical Manual, Live More Software Technology Corporation, 2004.
- [9] G. H. Liaghat, "Production of Multi Layer Tube (Stainless Steel and Carbon Steel) by Explosive Welding", *Energetic Materials J.*, Vol. 2, pp. 1 - 11, 2002.

- [10] Z. Liang, "Numerical Analysis of Tensile Damage and Blast Crater in Brittle Rock Due to Under Ground Explosion", *Mechanics and Mining Science J.*, vol. 44, pp 730-738, 2007.
- [11] M. Queen, "The Equation of States of Solid from Shock Wave Studies", 7nd ed., New York: McGraw-Hill, 1970, pp. 242-251.
- [12] S.A.A. Akbari Mousavi , M. Riahi and A. Hagh Parast, "Experimental and numerical analyses of explosive free forming", *Materials Processing Technology J.*, vol.187-188, pp 512-516, 2007.

**R. Alipour** was born in Abadan in south of Iran, on September 1981. He has obtained the Master degree on 2008 in Mechanical Engineering from Iran.

He has interested to study about metal forming process like Explosive forming, Hydro forming and Deep drawing. The other domain of his researches concerns the Non-linear FEM for modeling, Stress Analysis, Tool Monitoring and New method for characterizing of mechanical phenomena.

Mr. Alipour is a member of faculty in Islamic Azad University – Mahshahr branch in Iran as a researcher and lecturer in mechanical engineering. He is a member of ISME (Iranian Society of Mechanical engineering) and ISAEM (Iranian Scientific Association of Energetic Materials) since 2005. R.Alipour@mahshahriau.ac.ir

**F. Najarian** was born in Tehran, Iran, on 1982. He has obtained the Master degree on 2009 in Mechanical Engineering from Iran. He has interested to study about Tool Monitoring, Tool Wear and Traditional and Modern Machining Processes. The other domain of his researches concern the Non-linear FEM, Stress Analysis, Tool Monitoring and New method for characterizing in mechanical phenomena. Mr. Najarian is a lecturer on faculty Mechanical engineering in Islamic Azad University – saveh branch in Iran. He is a member of ISME (Iranian Society of Mechanical engineering).Farhad\_Nadjarian@yahoo.com