

Mitigation of Flicker using STATCOM with Three-Level 12-pulse Voltage Source Inverter

Ali Za'fari

Abstract—Voltage flicker is a disturbance in electrical power systems. The reason for this disturbance is mainly the large non-linear loads such as electric arc furnaces. Synchronous static compensator (STATCOM) is considered as a proper technique to mitigate the voltage flicker. Application of more suitable and precise power electronic converter leads to a more precise performance of the compensator. In this paper a three-level 12-pulse voltage source inverter (VSI) with a 12-terminal transformer connected to the ac system is studied and the obtained results are compared with the performance of a STATCOM using a simple two-level VSI and an optimal and more precise performance of the proposed scheme is achieved.

Keywords—Flicker mitigation, STATCOM, Inverter, 12-pulse, 3-level

I. INTRODUCTION

IN RECENT years, power quality in power systems becomes very important due to the growth of the industrial plants, increase in the energy consumption and diversity of the electrical loads [1]. Voltage flicker is one of the common problems that have a negative effect on the power quality. Electric arc furnace (EAF) is an important load in industry with very large active and reactive time varying powers in the melting and refining processes period which causes irregular voltage oscillation at the point of common coupling (PCC) [2]. This leads to an undesirable effect on the electric light sources, power electronics devices (within protective relays) and their lifetime [3]. IEEE519-1992 indicates that only 0.5% changes in the voltage amplitude leads to light intensity change which harms the human eyes [4, 5]. So voltage flicker mitigation is essential for the power systems.

Various techniques for reduction of the buses voltage fluctuations, below the standard limit, have been so far introduced. Considering the nature of the voltage flicker, which is rapid and unpredictable, a compensator used must quickly response to the voltage fluctuations and variations. Other important factors including non-bulky compensator (drawback of SVC), suitable harmonic behavior, unlimited kVar (drawback of active filters), disuse of expensive tools (drawback of smart trafo) [6], DG algorithm [3, 7], UPFC [8] and unlimited line commutation (drawback of dynamic phase controlling method) [9], must be taken into account.

Among various compensators that have been so far introduced, STATCOM has the above-mentioned features and is a desirable technique for voltage flicker mitigation [10]. The

primary duty of the STATCOM is regulating the voltage in order to improve the voltage profile of the power system [11]

The factor that plays a very important role in the improvement of the STATCOM performance is the use of power electronics converter as the core of the STATCOM. A more precise performance of the converter leads to a more precise compensator. In this paper, a three-level 12-pulsed PWM voltage source inverter (VSI) with a 12-terminal transformer connected to the ac system is proposed. It is expected that this structure is more precise than that of the simple two-level type, because a 12-pulsed three-level converter offers better sinusoidal waveform compared to that of the two-level one. On the other hand, a lower voltage harmonic leads to the use of low-voltage switches which are quicker, smaller and cheaper than that of the high-voltage switches in two-level case. In addition, a lower the THD, lower switching losses due to the lower switching frequency, a better overall efficiency of the system at full-load and consequently a smaller heat-sink and higher reliability are the other advantages of the three-level converters compared to that of the two-level converters [12]. As reported in [12], the total losses of the two-level converter are 44% higher than that of the three-level one. However, the two-level converter is 27% cheaper than that of the three-level configuration. The reasons are the dc link capacitors, IGBTs and more diodes and more complicated control strategy in the three-level converter. It is noted that the output dv/dt in the three-level converter is smaller than that of the two-level converter and consequently it has less stress on the cables [13]. Therefore, the higher cost of the three-level converters compared to the two-level one is justifiable. It is noted that a secure operation of the converter must be provided when one switch in the series switches fails to operate; it means that there need a number of additional switches which leads to a more expensive three-level converter. Use of the STATCOM is basically a costly process. On the other hand, the used transformer in the proposed converter has very lower output (1 kVA versus 1 MVA) compared to the 6-terminal type. Therefore, the cost of transformer is higher than the precious version, considering the output; it is economical in long-term run.

The paper has been organized as follows: Section II describes the principle of the STATCOM operation. Section III expresses the performance of a three-level converter and section IV analyzes the simulation results of this procedure. Finally section V concludes the paper.

II. PRINCIPLE OF STATCOM OPERATION

The STATCOM consists of two basic components: 1) a three-phase voltage source inverter (VSI) and 2) a step-down

A.Za'fari is with the Islamic Azad University-Neka branch (corresponding author to provide phone: 00989111518099; e-mail: Azafari@iauneka.ac.ir).

adaptive transformer. The latter component is interface between the power system and inverter. It is noted that this transformer, which connected in parallel with the bus, creates a limitation due to the elimination of harmonic by STATCOM. Since the transformer is not able to pass the harmonic currents. This compensator is connected in parallel with the furnace (or other non-linear load) to the furnace bus (for instance the system proposed in [14]), or PCC bus (the proposed system in [15]).

A general scheme of a STATCOM connected to an AC system has been presented in Fig. 1. If the primary voltage of the transformer (inverter side) becomes larger than that of the secondary voltage (system side), the current passes the AC power system through the leakage reactance (X) of the transformer, and inverter generates reactive power for the power system (capacitive case). If the secondary voltage of the transformer (inverter side) becomes larger than the primary voltage (system side), the reactive current passes from AC system to the inverter and inverter observes reactive power (inductive case). This current is calculated as follows:[16]

$$I = \frac{U_{acs} - U_{vsi}}{X} \tag{1}$$

where U_{acs} and U_{vsi} are the ac power system and VSI voltages, respectively and X is the leakage reactance of the transformer. In the case of equal secondary and primary voltage, interchange of the reactive power is equal to zero. The ac voltage difference across X generates reactive power exchange between the STATCOM and the ac power system which can be obtained as follows:

$$Q = \frac{1 - \frac{U_{vsi}}{U_{acs}}}{X} U_{acs}^2 \tag{2}$$

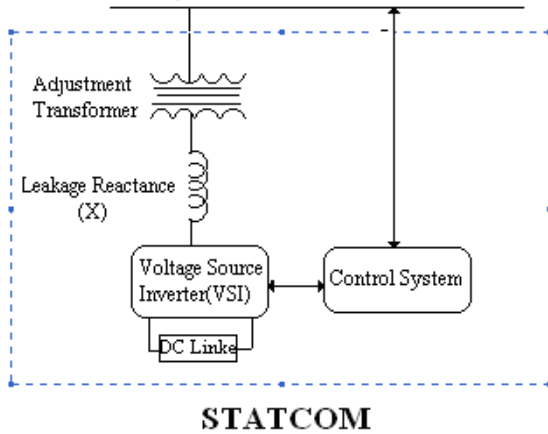

Fig. 1. A general scheme of a STATCOM connected to an AC system

Therefore, STATCOM helps to provide or inject the shortage or excessive reactive power in the system respectively. This helps to provide the load requirements as a compensator.

III. PERFORMANCE OF THREE-LEVEL CONVERTER

A three-level converter enables to vary the ac output voltage without forcing the change of the dc voltage, Fig. 2 shows one

of base phases of a three-level converter. As seen, any semi-base phase has been divided into two series valves: 1-1', 1A-1'A. The middle of the divided valves has been connected to the middle N by diodes D1 and D4. It seems that the valves number raises from two into four in any base phase. In addition, two extra diodes have been provided. However, doubling the valves number with the same permissible voltage level, will double the dc voltage, therefore the converter power is doubled. So, only adding D1 and D2 increases the converter cost. Presence of these diodes helps to divide the voltage between the two semi-valves.

Fig. 3 shows the output voltage of one base phase of a three-level converter. Waveform a is a complete 180 degrees square wave which generates $+V_d/2$ by switching on 1 and 1A over 180 degrees and $-V_d/2$ by switching 4 and 4A again over 180 degrees. Now consider waveform b, where 1 has been switched off and 4A has been switched on α degrees sooner than that of proposed 180 degrees case. In such a case, only 1A and 4A are switched on where by combination of diodes D1 and D4, phase voltage V_a (with reference to N), free from the current direction, is kept equal to zero. This case continues until 2α where 1A switches off and 4 switched on and voltage jumps to $-V_d/2$, while both lower 4 and 4a switched on and 1A switched off, etc. Of course angle α is variable and the

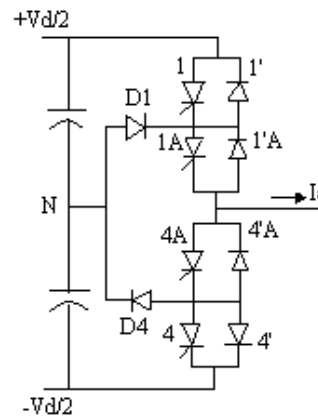

Fig. 2. A base phase of a three-level converter[16]

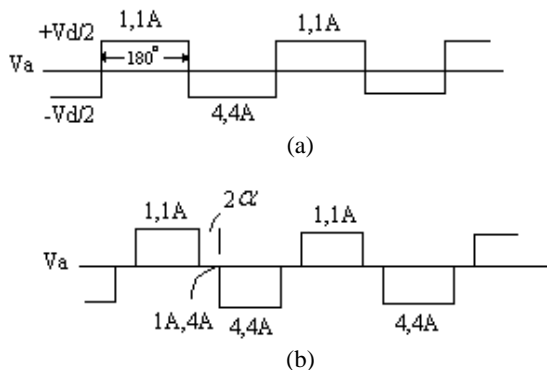

Fig. 3. Ac output voltage in: (a) a complete 180 degrees square and (b) less than 180 degrees square[16]

output voltage V_a consists of the square waveforms $\sigma=180^\circ-2\alpha^\circ$. This variable period σ over an half-cycle permits

practically that voltage V_a has been independently variable with quick response. It is clear that 1 and 4 switch on 180° degrees over any cycle and 1 and 4 over $\sigma=180^\circ-2\alpha^\circ$, while diodes D1 and D4 conduct over $2\alpha^\circ=180^\circ-\sigma$. For any instantaneous operation, the switching-off devices and parallel diodes do alternating and rectifying process respectively. The switch-on diodes D1 and D4 with lower devices 1A and 4A pass the current during the on time, where D1 and 1A carry the negative current (a current toward ac system), D4 and 4A carry the positive current. Finally, if three legs of phases are placed besides each other, a three-level six-pulsed converter is obtained. Now by cascading or paralleling three-level six-pulsed converters, a 12-pulsed type is obtained. It is expected that the more precise performance in generating a sinusoidal waveform and advantages of the above-mentioned converter leads to a precise and better performance of the controller. Fig. 4 shows the connections of a three-level 12-pulsed converter with its transformer.

In this structure two three-level converters are connected in series in the dc side in order to provide a 12-pulsed converter. In this case the output voltage contains harmonics $12n\pm 1$. The role of the transformer in the reduction of harmonics is considerable. The precise analysis of this topic is out of scope. Fig. 5 shows the phase output voltage in this structure which has been independently simulated. Comparison of Fig. 5 with the phase voltage in the three-level six-pulsed converter in Fig. 3 indicates a better quality of the output waveform from sinusoidal waveform point of view. Switching logic in the proposed method is PWM. Fig. 6 shows the general scheme of the logic. In this method, the generated reference currents are compared with the system currents and the compensated error by PI compensator as reference signal is compared with the carrier signal (specified in the figure). Depending to number 1, 0 or -1, the comparison result generates suitable commands for the corresponding switches with $+V_{dc}/2$, 0 and $-V_{dc}/2$.

IV. SIMULATION RESULTS ((2ND PROCEDURE)

In this section the system in [15] is considered and

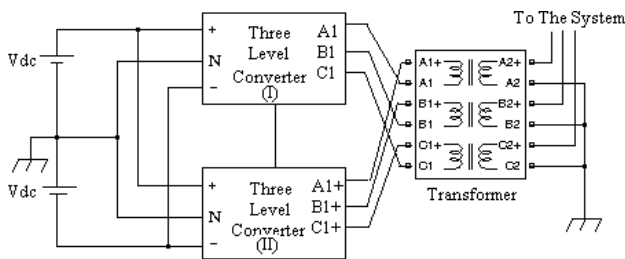

Fig. 4. Block diagram of proposed scheme for converter

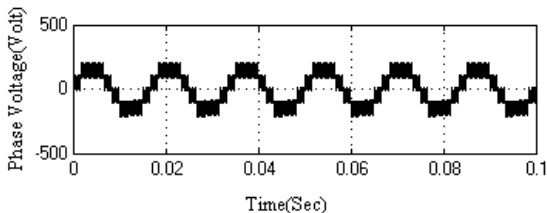

Fig. 5. Phase output voltage of a three-level 12-pulsed converter

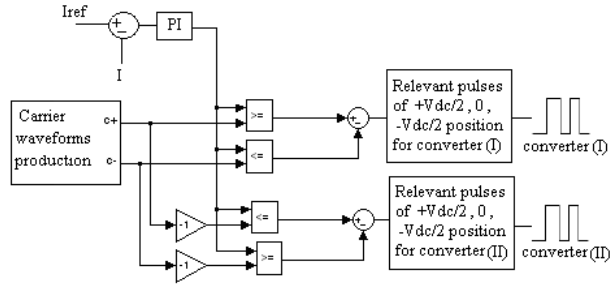

Fig. 6. PWM technique for switching

Only the two-level VSI (six-pulsed) is replaced by the converter having new structure. Fig. 7 shows the schematic of this system with a simple two-level VSI. In this converter a GTO is used as power electronics switch.

There are different models for EAF. Here, a time variant non-linear model of the EAF is used and shown its per phase model in Fig. 8. In this model, the product of the EAF phase current and simulation time (sinusoidally modulated) is applied to the controlled voltage source and generates a sinusoidal variations in the envelop of the bus voltage waveform, this is modeling of the fluctuations.

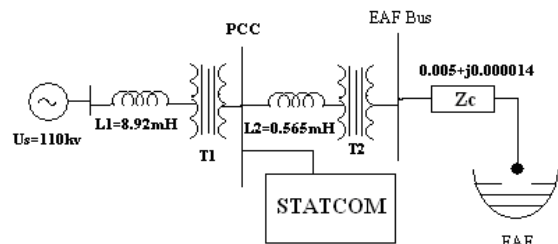

Fig. 7. Schematic of proposed system

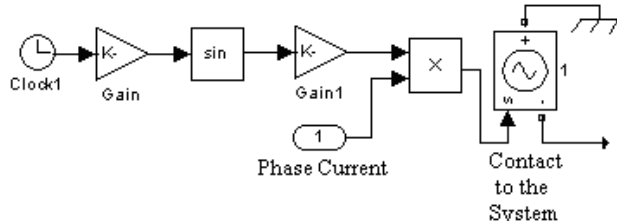

Fig. 8. Model of EAF[15]

This will show the efficient and positive role of the compensator with the new structure in mitigating and compensating the voltage flicker and its better performance compared with the simple two-level converter.

Fig. 9 shows the envelop of the PCC bus voltage waveform in two cases: with a simple two-level and three-level 12-pulsed converters. Comparison of Fig. 9a and Fig. 9b indicates that in the three-level 12-pulsed compensator, the envelop of the PCC envelop bus voltage is very smooth and fluctuations are almost zero. Therefore, a better quality and precision of the power electronics converter lead to a better performance of the compensator. All components of the compensators concerning all reference currents algorithm and control loop aim to

provide the necessary reactive current compensator for the system or absorb the excessive reactive current. This is the converter that is responsible to generate or absorb the reactive power according to the control loop. Therefore, it is deduced that the proposed converter has a better and more precise performance in the exchange of the reactive currents.

Performance of two STATCOM structures can be compared from supplied reactive power point of view in the compensated cases. Fig. 10 shows these powers. As seen, when a simple two-level converter is used 218.5 MVar reactive power is generated which is unable to fully respond the demand of the furnace; this is the reason for voltage variations in the buses of the system, while in the new structure of the compensator the network injects 217 MVar to the system and responds well to the load requirements, such that the voltage variations in PCC tends zero. It means that in this case the compensator is more powerful in providing the reactive power.

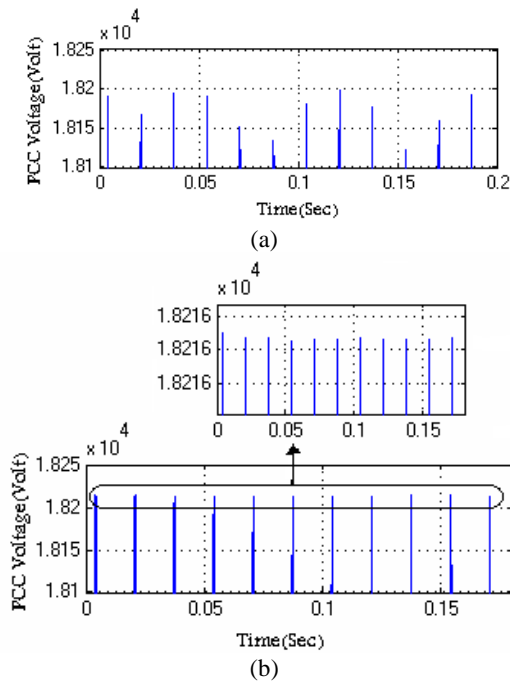

Fig. 9. PCC voltage in two compensator cases: (a) a two-level and (b) a 12 pulse three-level

Active power waveforms also show the positive aspects of the new scheme. In the two-level converter scheme, the supply is forced to generate 113.5 MW while in the new scheme this number is 112.7 MW. In the other words, in the new structure of the supply system generates 0.8 MW less power and also response with a better quality.

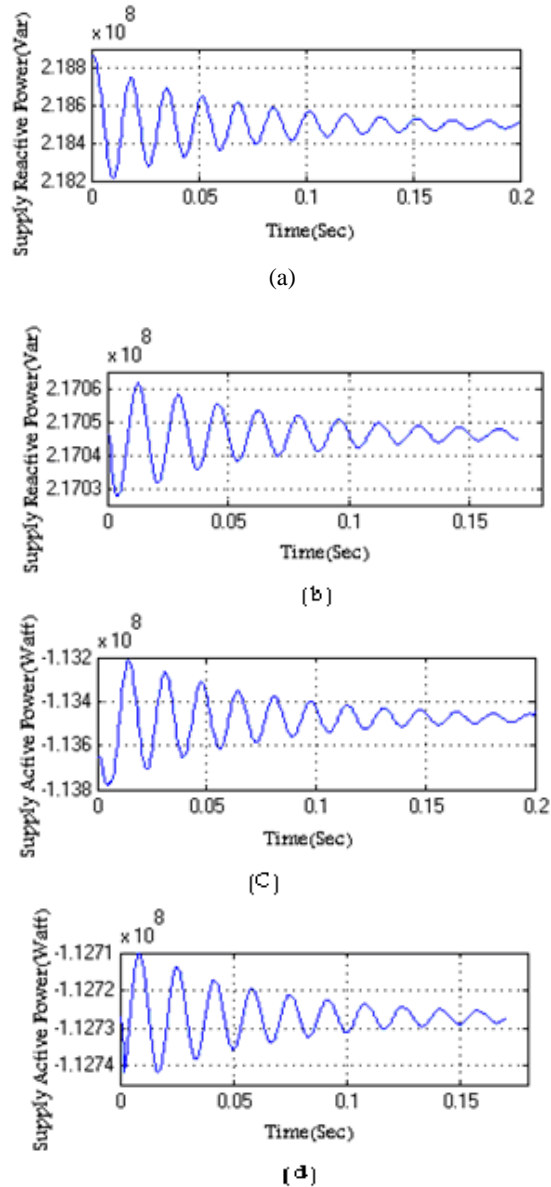

Fig. 10. (a) Reactive power supply for two-level converter, (b) reactive power supply for three-level 12-pulsed converter, (c) active power supply for two-level converter, and (d) active power supply for three-level 12-pulsed converter

Other problem that can be paid attention is the active and reactive power that generated by STATCOM and injects to the network as shown in Fig. 11. The output of the STATCOM in the first scheme is 1 MVar and 2 MW while these are 200 Var and 700 W respectively in the new scheme. It is noted that in the first scheme a 6-terminal transformer with 1 MVA power has been used while in the new scheme a 12-terminal transformer with 1 kVA power has been utilized. The transformation ratio and other specifications of the transformers are identical. Therefore, a lower power transformer with very lower output provides a more desirable respond and this is considered as a

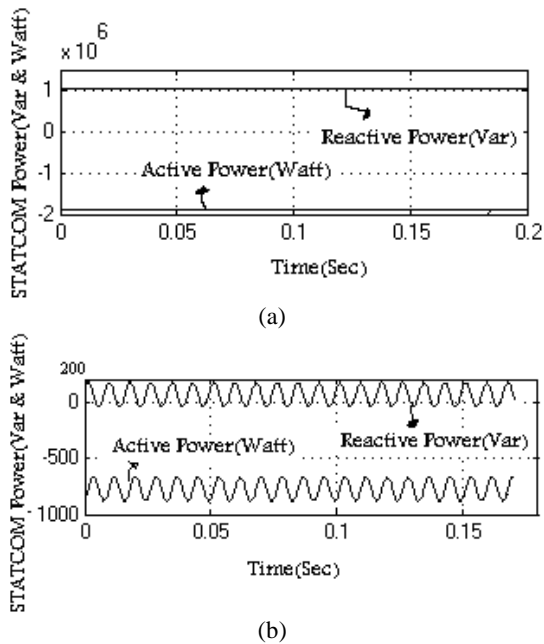

Fig. 11. Active and reactive STATCOM power in two schemes: (a) a simple two-level converter and (b) a (three-level converter

TABLE I
COMPARISON OF SIMULATION RESULTS

Converter type	PCC voltage variations (V)	Power station reactive Power (MVar)	STATCOM output
Two-level	75	218.5	1MW+2MVar
12 pulse three-level	0	217.0	700W+200 Var

very positive. It is noted that the transformer used is expensive due to the winding and iron; however considering very large difference in VA of the two transformers and smaller exchanged reactive and active currents in this case compared with the previous case, it cannot be concluded that the copper and iron losses are higher. In this case, there is no need to use expensive connection cables with large cross section and there is less stress on the cables. So, by spending more in transformer and converter, many expenses will be reduced.

Table I presents the simulation results. It indicates that the compensator in both structures has desirable performance and variations are in the permissible range (IEEE519-1992 standard). However, in this range the new structure shows a better performance.

In the system under study the EAF has been basically used as a reactive load. In actual system, there are variety of consumers with higher power factors, and overall this leads to a better power factor. Since in this system only one EAF has

been used as the load, the power factor is low. However, this cannot disturb the analysis and compensation of the reactive power. In the other words, compensation of the reactive power component is proposed.

V. CONCLUSION

In this paper it was indicated that the converter type used in the STATCOM can be one of the major factors in the compensator operation quality. The reason is that the target of all compensator elements such as reference currents algorithms and control loop is to provide the necessary reactive current compensator for the system or absorb the extra reactive current; this is the power electronics converter that generates or absorbs the reactive power according to the control loop. Investigation in this paper shows that application of the 12 pulse three-level converter provides quality compensation compared with that of the two-level converter. The reasons are:

- 12 pulse three-level converter*: The converter (or inverters) generates a waveform, depending on the number of pulses or level of the inverter, their precision and approximation level differ with the smooth sinusoidal. In the present case, a three-level, 12- pulse VSI and a two-level, 6-pulse VSI were proposed. Therefore, it was expected that the new scheme had more precision performance and compensation than that of the two-level type. Meanwhile, advantages of the three-level converter such as less stress on the cables compared to the two-level converter are clear.
- Type of Adaptive Transformer*: The used transformer is a new designed 12-terminal one with 1 kVA power and very lower output compared with that of the 6-terminal with 1 MVA power in the two-level converter. However, the performance of the compensator in the new case is better than that of the previous one. It means that a smaller power transformer with a very lower output has been used and more desirable respond has been achieved. This considers as a very positive aspect.

REFERENCES

- Chong Han, Alex Q. Huang, Subhashish B. hattacharya, and Mink Ingram, "Field Data-based Study Electric Arc Furnace Flicker Mitigation", IEEE Industry Applications Conference, 41st IAS Annual Meeting, Vol. 1, 2006, pp. 131-136.
- S.R. Mendis, M.T. Bishop, and J.F.Witte, "Investigations of Voltage Flicker in Electric Arc Furnace Power System", IEEE Industry Applications Magazine, Vol. 2, No. 1, 1996, pp. 28-34.
- M.I.Marei, E.F.EL-Saadany, and M.M.A.Salama, "An Intelligent Control For the DG Interface to Mitigate Voltage Flicker", 18th Annual IEEE Applied Power Electronics Conference and Exposition, APEC03., Vol. 1, 2003, pp. 179-183.
- C.Sharmeela, G.Uma, M.R.Mohan and K.Karthikeyan, "Voltage Flicker Analysis and Mitigation Case Study in Electric Arc Furnace Using PSCAD/MTDC", IEEE International Conf. on Power System Tech., 2004.

- [5] G.T.Heydt, M.bakroun, and A.Inan, "Voltage Flicker Estimation based on Linearization and Lp Norms", IEEE Trans. on Power Delivery, Vol. 18, No. 4, 2003.
- [6] H. Abdolrehman, and P. Bauer, "Flicker Mitigation with the Smarttrafo", European Conference on Power Electronics and Applications, 2005, pp. P.10.
- [7] Mostafa. I. Marei, Tarek. K. Abdel-Galil, Ehab. F. EL. Saadany, Magdy and M.A.Salama, "Hilbert transform based Control Algorithm of the DG Interface for Voltage Flicker Mitigation", IEEE Trans. on Power Delivery, Vol. 20, No. 2, 2005, pp. 1129 – 1133.
- [8] A.Elnady, W.El-Khattam and M.M.A. Salama, "Mitigation of AC Arc Furnace Voltage Flicker using the Unified Power Quality Conditioner", IEEE Power Engineering Society Winter Meeting, Vol. 2, 2002, pp. 735-739.
- [9] Chau-Shing, Wang,Michael, and J. Devaney, "Incandescent Lamp Flicker Mitigation and Measurement", IEEE Trans. on Instrumentation and Measurement, Vol. 53, No. 4, 2004, pp. 1028-1034.
- [10] Cong Han, Zhanoning Yang, Bin Chen, Alex Q. Huang, Bin Zhang, Mike Ingram and Aty Edris, "Evaluation of Cascade-Multilevel Converter Based STATCOM for Arc Furnace Flicker Mitigation", 14th IAS Annual Meeting, 2005, pp. 67-71.
- [11] M. S. El-Moursi and A.M. Sharaf, "Novel controllers for the 48-pulse VSC STATCOM and SSSC for voltage regulation and reactive power compensation", IEEE Trans. on Power Systems, Vol. 20, No. 4, Nov. 2005, pp. 1985-1996.
- [12] Ikonen, M., Laakkonen, O. and Kettunen, "Two-level and three-level converters comparison in wind power application, www. elkraft. ntnu.no/smola2005 /Topics/15.PDF.
- [13] <http://elkraft.ntnu.no/%7erichard1/mli.html>. Visited 29. 8.2005
- [14] Sun, D. Czarkowski and Z.Zabar, "Voltage Flicker Mitigation using PWM-Based Distribution STATCOM", IEEE Power Engineering Society Summer Meeting, 2002, pp. 616-621.
- [15] J.faiiz , A.Zafari" A Novel Algorithm for Determination of Rreactive Currents in STATCOM for Voltage Flicker Mitigation", 2th International Conf. on electrical Systems Design & technologies, Hammamet, Tunisia, Nov.8-10, 2008
- [16] N.G. Hingorani, L.Gayogi, "Understanding FACTS: Concepts and Technology of Flexible AC Transmission Systems", Wiley, 2000