

# Mitigation of Electromagnetic Interference Generated by GPIB Control-Network in AC-DC Transfer Measurement System

M. M. Hlakola, E. Golovins, D. V. Nicolae

**Abstract**—The field of instrumentation electronics is undergoing an explosive growth, due to its wide range of applications. The proliferation of electrical devices in a close working proximity can negatively influence each other's performance. The degradation in the performance is due to electromagnetic interference (EMI).

This paper investigates the negative effects of electromagnetic interference originating in the General Purpose Interface Bus (GPIB) control-network of the AC-DC transfer measurement system. Remedial measures of reducing measurement errors and failure of range of industrial devices due to EMI have been explored. The AC-DC transfer measurement system was analysed for the common-mode (CM) EMI effects. Further investigation of coupling path as well as much accurate identification of noise propagation mechanism has been outlined. To prevent the occurrence of common-mode (ground loops) which was identified between the GPIB system control circuit and the measurement circuit, a microcontroller-driven GPIB switching isolator device was designed, prototyped, programmed and validated. This mitigation technique has been explored to reduce EMI effectively.

**Keywords**—CM, EMI, GPIB, ground loops.

## I. INTRODUCTION

GROWING complexity of electronic and communication devices leads to emergence of various electromagnetic interference (EMI) sources that hinder the stable operation of these devices. EMI is a spurious electromagnetic energy that pollutes electronics and electrical equipment. The ac-dc transfer measurement system stability and accuracy are limited by electromagnetic interference. The high-accuracy low frequency ac-dc measurements are particularly susceptible to the conducted EMI, which can be produced in the measurement circuit by differential-mode (DM) and common-mode (CM) current and voltage components originating from the external sources coupled with the measurement circuit [1], [2].

The negative effects of EMI are obstruction, degradation and limitation of the effective performance of electronics and electrical devices.

The conducted EMI passes through supply lines, electronic control networks and interconnecting wires and cables. It is desirable to find effective measures of dealing with the

conducted EMI problems to avoid measurement uncertainties and costly equipment failures in industry. To secure an interference-free environment, mitigation techniques are desired to overcome the EMI problem. In this paper, the negative impact of the common-mode EMI (ground loops) on the ac-dc transfer measurement system will be scrutinised. The technical solution to prevent ground loops has been explored and validated.

## II. AC-DC TRANSFER MEASUREMENT SYSTEM

The AC-DC transfer measurement system joins up to 5 different instruments and a PC with the Automated Measurement System (AMS) control software into a network of the IEEE 488.2 (GPIB) interfaces.

The diagrams in Fig. 1 assume that the dc source is not susceptible to the conducted EMI in contrast to the ac source which is with more likelihood considered to contain coupling between the control and generation circuits, involving multiple reactive components.

## III. PROBLEM IDENTIFICATION

It was experimentally observed that the control-plane currents, originating in the GPIB network, can penetrate the measurement plane through coupling between the ac source's generation circuitry and GPIB control module, and flow towards the central ground point causing thermal converter response observed at the measurement instrument even when no measured signal is applied at the input [4], [5]. Fig. 2 shows one of the hypothetical ground loops that could be formed in such a configuration.

The differential input of the transconductance amplifier leaves possibility of the output current gain fluctuation due to the EMI-induced Lo-to-ground voltage noise. It is therefore necessary to comprehend the ground loops in the ac-dc measurement system through common-mode (CM) interference error analysis so that a custom solution could be designed to prevent loop occurrence in the measurement plane. The critical requirement to this solution is a non-intrusive design with regard to the measurement plane that would exclude measurement accuracy deterioration.

## IV. MITIGATION OF EMI GENERATED FROM THE GPIB CONTROL NETWORK

A programmable GPIB bus isolator implementing the automated GPIB channel switching has been developed at the

M. M. Hlakola is with University of Johannesburg and National Metrology Institute of South Africa, E. Golovins is with the National Metrology Institute of South Africa, Electrical Metrology, DCLF Section (phone: 012 841 1700; e-mail: mhlakola@nmisa.org, egolovins@nmisa.org).

D.V. Nicolae is with the Electrical Engineering Technology Department, University of Johannesburg, (e-mail: dnicolae@uj.ac.za).

AC-DC Difference Laboratory. The ultimate goal of the isolator is to prevent any EMI path through the GPIB bus, the risk of ground loop occurrence and EMI-induced error when the meter processes a measured sample. The following concepts were adopted in the approach to the GPIB isolator and its control module design:

- +12 Vdc supply to power both the channel switching array and control module of the isolator;
- Complete electric cut-off of each of the 24 wires in the GPIB bus using relay circuit breakers;
- Arduino Uno R3 MCU with the USB 2.0 interface for reconfigurable channel selection in accordance with the

requested instrument's GPIB address.

The basic schematic diagram of the switching isolator control module is shown in Fig. 3. The circuit is characterised by the following features:

- Electrical isolation of the MCU digital outputs from the rest of the module through the use of optocouplers;
- Capacity to expand the maximum number of programmatically switched GPIB channels, determined by the number of vacant MCU digital outputs (up to 7 channels).

A photo of the developed GPIB isolator device is shown on Fig. 4.

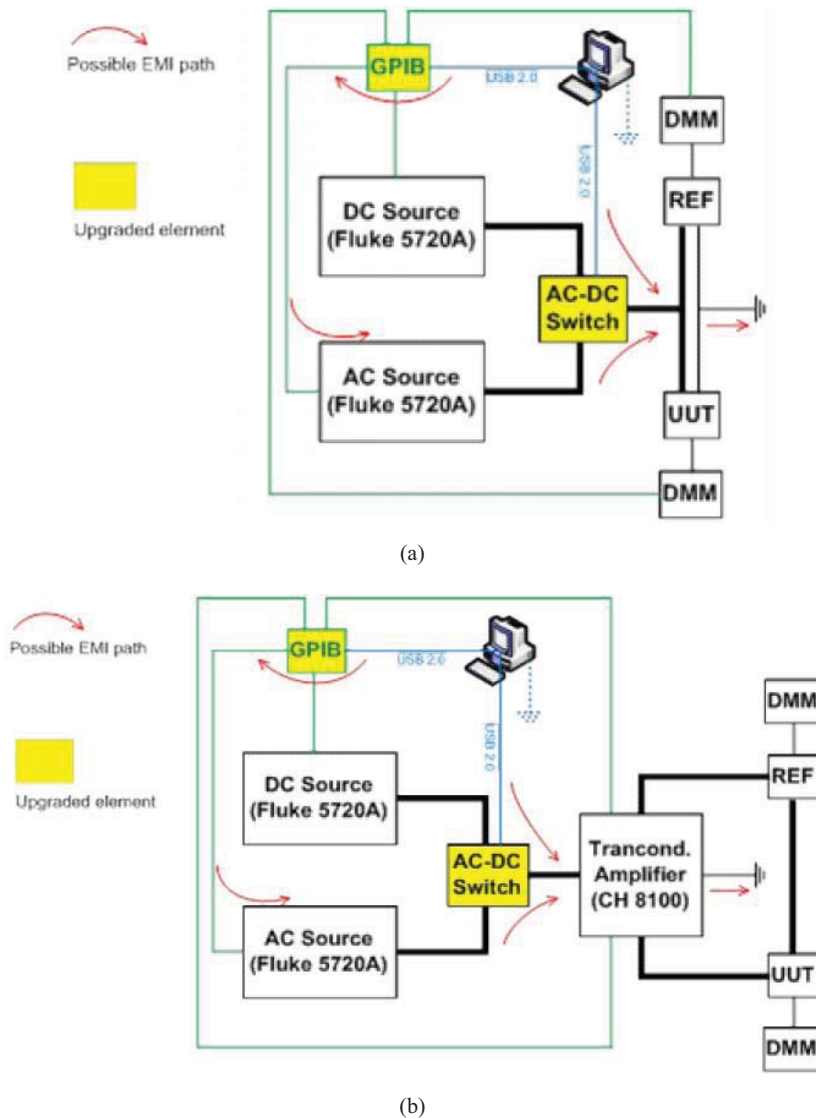

Fig.1 Schematic diagrams of ac-dc transfer measurement system: (a) for voltage measurements; (b) for current measurements [3]

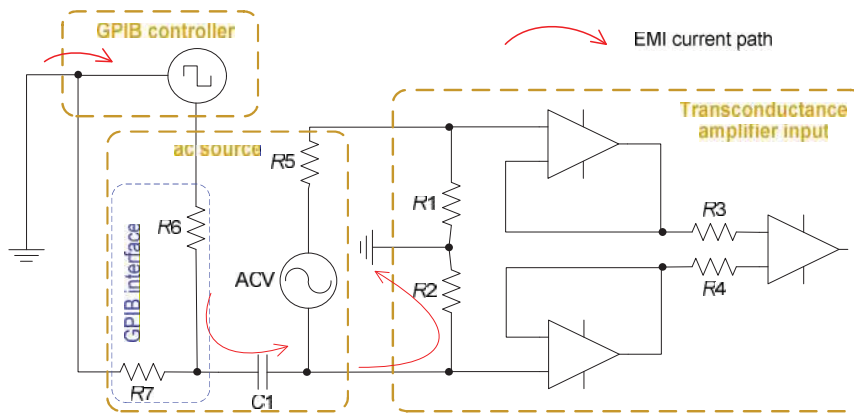

Fig. 2 Ground loops through coupling between the GPIB bus and primary measurement network

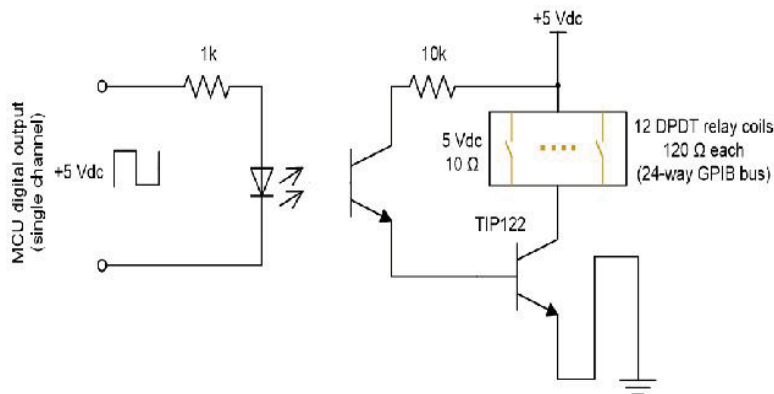

Fig. 3 Basic schematic diagram of the switching isolator control module [6]



Fig. 4 Programmable GPIB switching isolator (up to 7 channels)

To illustrate the principle of operation of the developed GPIB isolator, a simplified measurement system consisting of a network of 3 instruments is considered (Fig. 5): dc source (channel 0), ac source (channel 1) and meter (channel 2).

The input of the isolator is attached to the GPIB controller with the PC connection and the switched outputs are connected with the GPIB interface modules on the instruments. The meter measures instruments in two periodic

states of the measurement system configuration: dc input and ac input.

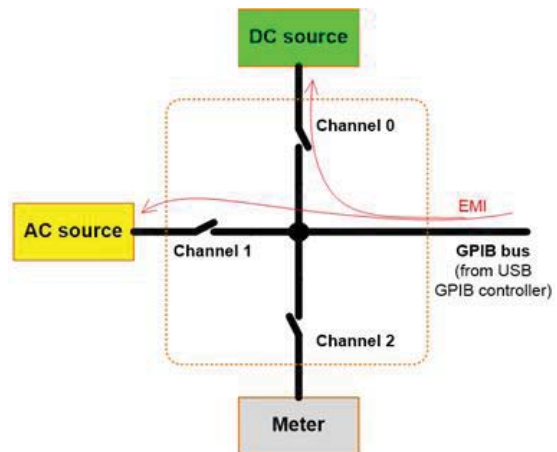

Fig. 5 Three-instrument GPIB network

The time diagram (Fig. 6) contains a sequence of the following control stages through the GPIB network (initially all GPIB channels are disabled and dc input is set in the meter). The basic operation of the isolator is outlined below:

- |  |  |
|--|--|
| (1) Setting the ac source output level (GPIB Channel 1 enabled); | (5) Measured sample processing by the meter (all channels disabled);     |
| (2) Switching from dc to ac (all GPIB channels disabled);        | (6) Read processed meter's response to the ac input (Channel 2 enabled); |
| (3) Setting the dc source output level (Channel 0 enabled);      | (7) Switching from ac to dc (all GPIB channels disabled), etc.           |
| (4) Reset meter's filter (Channel 2 enabled);                    |  |

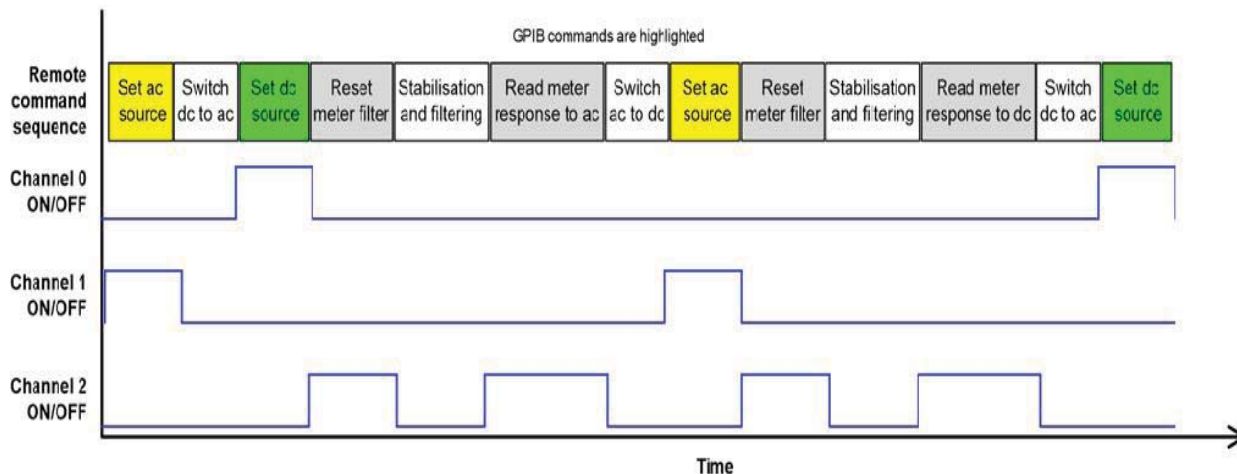

Fig. 6 Isolator switching time diagram

V. VALIDATION OF THE UPGRADED AC-DC TRANSFER MEASUREMENT SYSTEM

The upgraded AC-DC transfer measurement system has been validated. The list of equipment used in the measurement system is given as follows:

- 2 Fluke 5720A calibrators, s/n 7790203 (dc source) and 6700201 (ac source);

- 2 Keithley 182 digital nanovoltmeters, s/n 0685929 and 0685931;
- Clarke-Hess 8100 transconductance amplifier, s/n 411;
- Common-mode noise filter (choke);
- Cables, adapters and connectors.

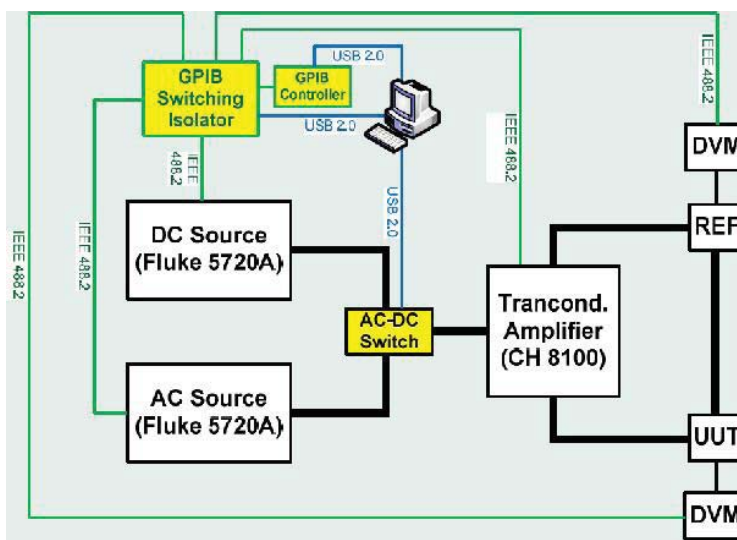

Fig. 7 Upgraded AC-DC current transfer measurement system

The implementation of GPIB isolator has been verified by obtaining the ac-dc current transfer difference measurements for unit under test (UUT) thermal current converter against the reference (REF) national thermal current converter standard.

Ten measurements were obtained for 0.01 A rms current input at various frequencies (kHz) for the UUT and REF.

The AC-DC current transfer measurement results are graphically plotted in Fig. 8.

TABLE I  
AC-DC CURRENT TRANSFER DIFFERENCE

No.	Freq. (kHz)	NMISA verification (UUT)		NPL calibration certificate (REF)	
		AC-DC diff. ( $\mu\text{A/A}$ )	Uncertainty ( $\pm\mu\text{A/A}$ )	AC-DC diff. ( $\mu\text{A/A}$ )	Uncertainty ( $\pm\mu\text{A/A}$ )
1	0.01	44	41	34	12
2	0.02	10	41	12	11
3	0.04	1	39	5	11
3	0.1	-4	40	3	11
5	1	-1	39	2	11
6	5	-2	40	1	11
7	10	0	40	0	13
8	20	2	40	1	14
9	50	-2	42	2	15
10	100	-4	43	10	22

## VI. SUMMARY

The EMI source and propagation path have been outlined and discussed. A GPIB isolator was successfully designed and

implemented to reduce the measurement errors due to EMI in the ac-dc measurement system. The ac-dc current transfer measurement system has been upgraded and verified. Measurement data shows significantly improved stability and repeatability in comparison with the NPL-certified values.

## VII. PROJECT IMPACT

The developed EMI mitigation mechanism enhances the calibration capabilities of the ac-dc transfer measurement system. Reduction of the AC-DC difference measurement uncertainty through the developed EMI mitigation mechanisms will have a major impact on the NMISA alternating voltage and current calibration and measurement capability that will directly benefit the South African network of accredited calibration laboratories, industry and Department of Trade and Industry (dti) Technical Infrastructure through the traceability dissemination at higher test uncertainty ratios (TURs).

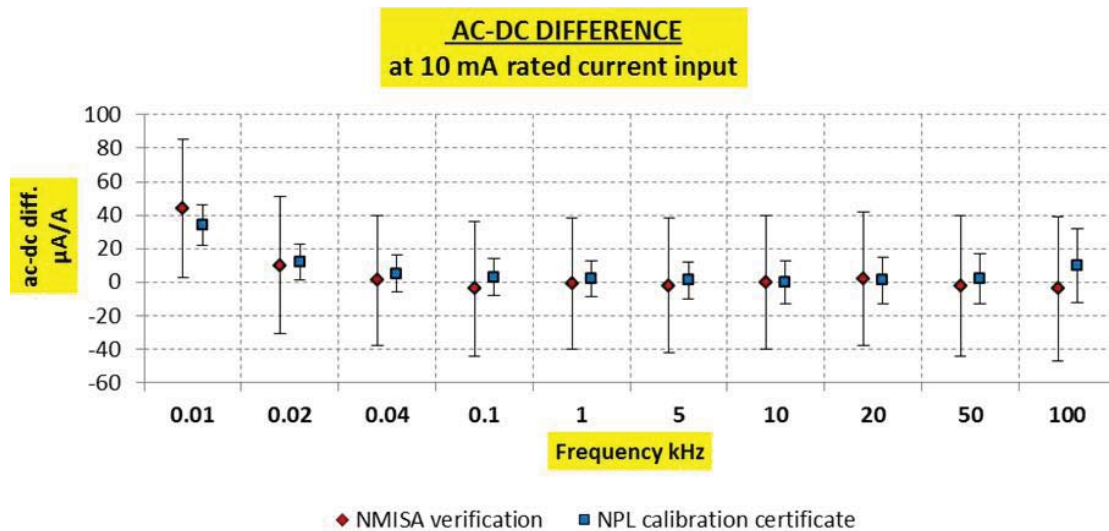

Fig. 8 NMISA AC-DC transfer difference verification against the NPL calibration certificate

## ACKNOWLEDGMENT

We are thankful to the NMISA and NRF for working resources and support. The development of the device was carried out by Dr. E. Golovins and Mr. F. Prinsloo whose efforts in this regard are gratefully acknowledged. The supervision of Prof. D.V. Nicolae cannot go unnoticed, thank you so much.

## REFERENCES

- [1] A. E. Ruehli and H. Heeb, "Circuit models for three-dimensional geometries including dielectrics", IEEE transactions on Antennas and Propagation, Vol. 40, pp. 1507-1516, 1992.
- [2] T. Weiland, "A discretization method for the solution of Maxwell's equations for six components fields", Electronics and Communication, (AEU), Vol. 31, pp. 116-120, 1977.
- [3] DCLF/U-0005: Procedure for Calibration of AC-DC Voltage Transfer Standards.
- [4] D. Deaver, "Calibration and traceability of a fully automatic ac measurement standard" in Proc. Of NCSL Workshop & Symposium, 1991.
- [5] Noise Reduction and Isolation. White Paper. Measurement Computing: <http://www.mcdaq.com/PDFs/specs/Noise-Reduction.pdf>
- [6] E Golovins, F. Prinsloo, A.M Matlejoane" NMISA-14-00267 Technical Report: Improvement of ac-dc transfer difference calibration and measurement capabilities", pp. 23-26, 2015.