

Automatic ECG Beat Tachycardia Detection Using Artificial Neural Network

R. Amandi, A. Shahbazi, A. Mohebi, M. Bazargan, Y. Jaber, P. Emadi, and A. Valizade

Abstract—The application of Neural Network for disease diagnosis has made great progress and is widely used by physicians. An Electrocardiogram carries vital information about heart activity and physicians use this signal for cardiac disease diagnosis which was the great motivation towards our study. In our work, tachycardia features obtained are used for the training and testing of a Neural Network. In this study we are using Fuzzy Probabilistic Neural Networks as an automatic technique for ECG signal analysis. As every real signal recorded by the equipment can have different artifacts, we needed to do some preprocessing steps before feeding it to our system. Wavelet transform is used for extracting the morphological parameters of the ECG signal. The outcome of the approach for the variety of arrhythmias shows the represented approach is superior than prior presented algorithms with an average accuracy of about %95 for more than 7 tachy arrhythmias.

Keywords—Fuzzy Logic, Probabilistic Neural Network, Tachycardia, Wavelet Transform.

I. INTRODUCTION

IN recent years automated data analysis techniques have drawn great attention and are used in almost every field of research including biomedical. Artificial Neural Networks (ANNs) are one of the Computer-Aided-Diagnosis tools which are used extensively by advances in computer hardware technology [1]. The application of these techniques for disease diagnosis has made great progress and is widely used by physicians. An Electrocardiogram carries vital information about heart activity and physicians use this signal for cardiac disease diagnosis which was the great motivation towards our study. In our work, tachycardia features obtained are used for the training and testing of a Neural Network.

The electrocardiogram (ECG) inherently carries important information on functionality of the heart. This signal provides a physician with crucial information on a patient's heart function and can be used for the prognosis and diagnosis of

heart disease. It is one of the most common signals used in diagnosis because of its non-invasive nature and the valuable information it contains. Its analysis can be used to judge the pathophysiological condition of the heart. Several systems have been developed for ECG recording and analysis [2]. Early ECG systems were just recording the signal by printing it. New systems use computer technology to provide automated diagnosis. The latter is a large research field and many methods and approaches have been proposed and implemented for the detection of ischemia, arrhythmia detection and classification, and diagnosis of chronic myocardial diseases. Those methods usually include processing of the signal and removing noise and artifacts, extracting certain key features related to diseases, and analyzing the features to make the final decision. The analysis is usually done by using signal processing, artificial neural networks, and fuzzy logic concepts along with the clinical symptoms provided by medical experts. The performance of those systems is evaluated using standard databases. The ECG record on the skin in one direction, where, generated electrical vectors by the heart are changing and moving in three dimensional space, will not give enough information. That is why basically ECG has 12 vectors recording signals in 12 dimensional space where 6 of them are in the horizontal plane and the other 6 in the frontal plane and they are all called ECG leads. These leads record signal by placing electrodes on the patient's upper and lower limbs and chest. A physician analyses the ECG by having prior knowledge on the space angle of each lead and looking at the plotted signal of the leads. while to classify arrhythmias signals we need only short part of signal in time measure for reliable detect of tachy signals we must use the vital features of signals and correlation between them. It is also useful to use the clinical information to accurate detection. tachy arrhythmia have higher risk than other cardiovascular arrhythmias.

II. DATA

Performance evaluation was carried out using the MGH/MF tachyarrhythmias database which be a collection of electronic recordings of hemodynamic and electrocardiographic waveforms of stable and unstable patients in critical care units, operating rooms, and cardiac catheterization laboratories. this database annotated with heart rate, sampling frequency and other useful information needed. this database was developed at Massachusetts General Hospital/Marquette Foundation ,We also used CU Ventricular Tachyarrhythmia Database, MIT-

R. Amandi was with University of Zanjan, Zanjan, Iran. He is now with the Department of Computer Engineering, Roozbeh Institute of Higher Education, Zanjan, Iran (e-mail: amandi@roozbeh.ac.ir).

A. Shahbazi is with the Physics Department, University of Zanjan, Zanjan, Iran (e-mail: ayda.shahbazi@znu.ac.ir).

A. Mohebi is with the Physics Department, University of Zanjan, Zanjan, Iran (e-mail: alimohebbi@roozbeh.ac.ir).

M. Bazargan is with the Physics Department, University of Zanjan, Zanjan, Iran (e-mail: bazargan@znu.ac.ir).

Y. Jaber is with the Zanjan University of Medical Sciences, Zanjan, Iran (e-mail: yahya.jaber@zums.ac.ir).

P. Emadi is with the Roozbeh Institute of Higher Education, Zanjan, Iran (e-mail: emadi@roozbeh.ac.ir).

A. Valizade is with the Physics Department, Institute for Advanced Studies in Basic Sciences(IASBS), Zanjan, Iran (corresponding author; e-mail: valizade@iasbs.ac.ir).

BIH Normal Sinus Rhythm databases to evaluate and compare with similar methods [3],[4].

III. METHODS

In this study we are using Fuzzy Probabilistic Neural Networks as an automatic technique for ECG signal analysis. As every real signal recorded by the equipment can have different artifacts, we need to do some preprocessing steps before feeding it to our system. Wavelet transform is used for extracting the morphological parameters of the ECG signal. We have developed an automatic tachys detection method which is based on the number of P and QRS interval patterns per a minute as a string and have calculated the correlation between them. We had an approach in our investigation, which uses the whole signal with 60 sec data chunks which are normalized and de-noised signals as input to the wavelet and get the fuzzy rules from it as input to ANN.

Each data can belong in more than one cluster of diseases, hence Neural Network is not able to diagnose the uncertainty on ECG's data and classifies them in quanta forms which is far from the nature of our data, we used fuzzy algorithm which is consisted of more trustable inputs to neural networks.

The block diagram of the proposed method for ECG beat classification is depicted in Fig. 1. The method is divided into three steps: (1) preprocessing (2) calculation of feature vector and (3) classification by ANFIS.

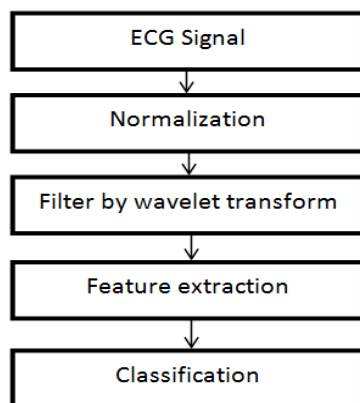

Fig. 1 System block diagram

The ECG feature extraction plays a very important role in disease diagnosis. The amplitudes and interval values of P-QRS-T waves determine the functionality of the heart of every human and the majority of the clinically important information in the ECG is in the intervals and amplitudes of these waves. An accurate diagnosis of arrhythmia will be possible by the precise detection of P, QRS and T waves. If the beat is similar to a normal beat it is easy to detect the waves by eye, but it could be rather challenging in cases of an abnormal shape of the beat. The waves are studied by some parameters of amplitude and time. Some techniques have been proposed for automatic detection of these parameters [5], [6].

In this work we use the wavelet transform technique. The wavelet transform is a transformation between time and

frequency domains. In contrast to some transformation like Fourier transform, wavelet could be localized both in time and frequency [7]. The main equation of the transformation is called the "mother wavelet" and has to satisfy some conditions [8]. Parameters a and b are the width of the signal and the time localization center respectively. In 1989 R. Coifman introduced a new class of wavelets which are called coiflet [9]. In this class of wavelet the mother wavelet must have zero momentum. Another parameter in coiflet transform is order of coiflet. The order of coiflet is chosen in a way that the transformed data best fits the original data. The numerical procedures are done in MATLAB using wavelet toolbox and the coiflet transform of order 1 is used [10].

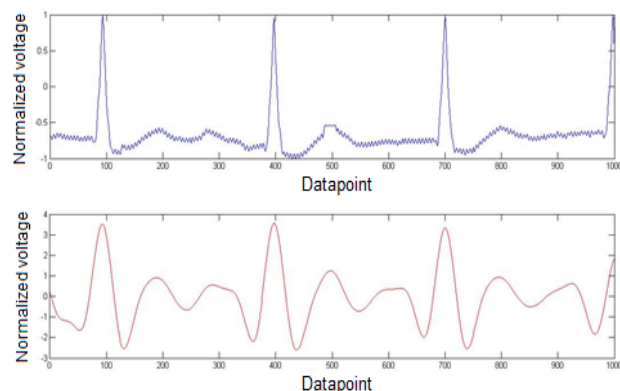

Fig. 2 A transformed beat. Using this transformation, Q, R, S and P are determined; By determine this parameters we muse calculate correlation between them

One of the more important steps in ECG signals processing is denoising. Voltage sensors are placed on the skin in the vicinity of the heart. The signal measurement and the initial signal processing with the instrument. The presence of noise in all electrical elements causes the Instrumentation noise. The electrode probes, cables and amplifier are the primary elements for ECG. These three elements and any other element like Analog-to-Digital converter and Signal processor contain white Gaussian noises themselves. These noises in the ECG signal are to be removed for the automatic disease diagnosis. In most of the signal processing cases, de-noising is one of the important and required steps for proper signal processing. Here we used Wavelet transform for de-noising and the first order coiflet from MATLAB toolbox is used for this transformation.

IV. CLASSIFICATION

We have used Fuzzy Probabilistic Neural Networks (PNN) among the intelligent algorithms for classification of input data. Because of uncertainties we use fuzzy logic to better analyze input data. We defined if-then rules to calculate fuzziness [11]. The PNN algorithm learns the prediction of Probability Density Function (PDF). It's architecture consist of four layers, shown in Fig. 3.

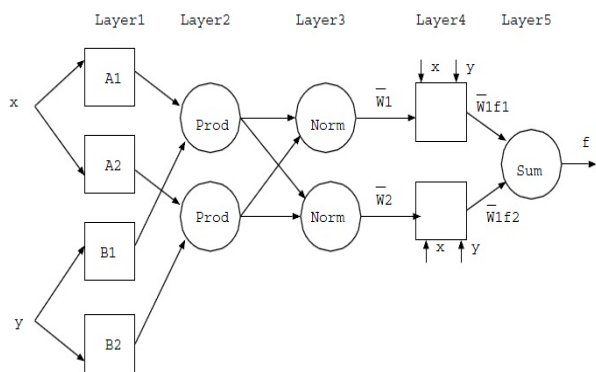

Fig. 3 Architecture of PNN

The first layer is the input layer and fully connected to the next layer.

Input vector $X = (x_1, x_2, \dots, x_n) \in R^2$ is applied to n neurons of input layer. The second layer in which the input vectors are stored, is called the pattern layer. In the second layer including $n \cdot K$ neurons, the distance between the input vector and each one of K training examples is calculated; The third layer is the summation layer, which has K elements. Each element in this layer combines via processing elements in the pattern layer through the following estimator:

$$S_k(x) = \frac{1}{(2\pi\sigma^2)^{n/2} N_k} + \sum_{i=1}^{N_k} \exp\left(-\frac{\|X - X_{k,i}\|^2}{2\sigma^2}\right)$$

where σ , known as the spread or smoothing parameter is the

TABLE I
COMPARE RESULTS OF DIFFERENT METHODS

Method	Accuracy	Number of Disease
ANFIS[15]	97%	6
PNN[16]	85.30%	2
Bayesian[17]	90%	2
Proposed	95%	7

deviation of the Gaussian function and $X_{k,i} \in R^2$ is the center of the kernel. Finally, the output layer select the neuron in the summation layer with the maximum output [12].

$$C(X) = \arg \max_{1 \leq k \leq K} (S_k).$$

to select stable version of algorithm we divide dataset into five subdatas and at each step one of them used for train and other four subdatas used to test the system performance. At last average accuracy for five iteration used as system performance [13].

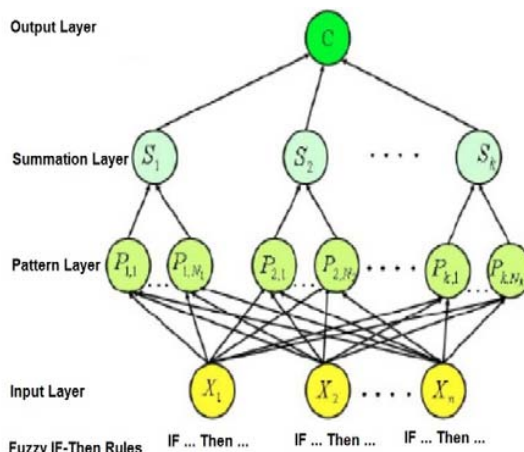

Fig. 4 Architecture of Fuzzy Probabilistic Neural Network

V. RESULTS

The outcome of the approach for the variety of arrhythmias, shows the represented approach is superior than prior presented algorithms with an average accuracy of about %95 for more than 7 tachy arrhythmias which consist of Sinus Tachycardia, Atrial Tachycardia, Atrial Tachycardia with block, Atrial Fibrillation, Atrial Flutter, Ventricular Tachycardia, Ventricular Fibrillation. We have developed an automated system that works with the Probabilistic Neural Network algorithm and gives a promising result; which we evaluated based on Accuracy which are defined as the following [14]:

$$Accuracy = \frac{TN + TP}{TN + TP + FN + FP}$$

VI. CONCLUSION

This is a novel method for characterizing tachycardia in the ECG using and comparing fuzzy rules clustering and statistical algorithms adventures. We have studied several tachy arrhythmias with high detection accuracy. In the literature, previous attempts are made on 3 types of tachy arrhythmias. The result of the F-PNN shows that its performance for fuzzified inputs has the best performance. Also it was noticed that the proper selection of training and testing data sets are of great importance and all the beats of each arrhythmia should not be selected from a single file in the database. Hence the Introduced algorithm is simple enough with more accuracy and running time, it can be used as an application software to construct ICD systems.

REFERENCES

- [1] PHW. Leong, "A Low Power VLSI Arrhythmia Clasifier" in *IEEE Transaction on neural networks*, vol. 6, No 6, 1995, pp. 1435-1445.
- [2] Gari D. Clifford, *Signal Processing Methods For Heart Rate Variability Analysis*, University of Oxford, 2002.
- [3] A.L. Goldberger, L.A.N Amaral, L. Glass, J.M. Hausdorff, P.Ch. Ivanov, R.G. Mark, J.E. Mietus G.B. Moody, C.K.Peng, H.E. Stanley, *PhysioBank, PhysioToolkit, and PhysioNet, Components of a New*

- Research Resource for Complex Physiologic Signals, American Heart Association, 2000.
- [4] <http://www.physionet.org/physiobank>.
 - [5] J Pan, WJ Tompkins, A real time QRS detection algorithm, Biomed Eng IEEE Trans, vol. 3, 1985, pp. 230-236.
 - [6] JP Sahoo, Analysis of ECG signal for detection of cardiac arrhythmias, 2011.
 - [7] A Graps, An Introduction to wavelets, Computation Science & Engineering IEEE, vol.2, 1995, pp. 50-61.
 - [8] PS Addison, Wavelet transform and the ECG, Physiol, Meas 2005, pp. 155-199.
 - [9] I Daubechies, Ten Lectures on wavelets, SIAM, 1992.
 - [10] M. Elgendi, R wave detection using coiflets wavelets, Bioengineering Conference, IEEE 35th Annual Northeast, 2009.
 - [11] V. Kecman, Learning and Soft Computing Support vector machines-Neural Networks-Fuzzy Logic, MIT, 2001.
 - [12] DF Spetch, Probabilistic Neural Network, Neural Networks, vol. 3, 1990, pp. 109-118.
 - [13] HA Guvenir, B Acar, Feature Selection using a Genetic Algorithm for the detection of abnormal ECG recordings, International Conference on Machine Learning, Florida, 2001.
 - [14] W Zhu, N Zeng, N Wang, Sensitivity-Specificity-Accuracy Associated and ROC Analysis with practical SAS implementation, NEGUS, 2010.
 - [15] TM Nazmy, H El.Messiry, F Al-Bokhity, Adaptive Neuro-Fuzzy Inference system for classification of ECG signals, Journal of Theoretical and Applied Information Technology, 2009.
 - [16] F Belhachat, N Izoboudjen, Application of a probabilistic neural network for classification of cardiac arrhythmias, 13th International Research/Expert Conference" Trends in the development of machinery and associated technology", Tunisia, 2009.
 - [17] D Gao, M Madden, Arrhythmia Identification from ECG Signals with a Neural Network Classifier Based on a Bayesian Framework, 24th SGAI International Conference on Innovative Techniques and Applications of Artificial Intelligence, 2004.