

Meshed Antenna for Ku-band Wireless Communication

Chokri Baccouch, Chayma Bahhar, Hedi Sakli, Nizar Sakli

Abstract—In this article, we present the combination of an antenna patch structure with a photovoltaic cell in one device for telecommunication applications in isolated environments. The radiating patch element of a patch antenna was replaced by a solar cell. DC current generation is the original feature of the solar cell, but now it was additionally able to receive and transmit electromagnetic waves. A mathematical model which serves in the minimization of power losses of the cell and therefore the improvement in conversion performance was studied. Simulation results of this antenna show a resonance at a frequency of 16.55 GHz in Ku-band with a gain of 4.24 dBi.

Keywords—Electric power collected, optical and electrical losses, optimization of the grid of collection, patch antenna, photovoltaic cell.

I. INTRODUCTION

SINCE the 70's, there has a considerable expansion of micro-antennas or patch antennas, favored by the progress of micro-electronics of technology in the field of miniaturization and electronic integration. Today, with the explosion of telecommunications, wireless commercial applications encounter many constraints. The past decade witnessed a rapid use of patch antennas, which have been proposed to meet the requirements in communication and radar systems. They have received much attention in recent years and found many applications in a wide range of frequencies. They are small, simple, and easy to manufacture and implement. In addition, they adapt easily to planar and non-planar surfaces and exhibit high robustness when mounted on rigid surfaces. They are also very efficient in terms of resonance, input impedance and radiation pattern [1], [2].

Improving the performance of a solar cell depends not only on the materials and structure but also on the design of the metal grid front face. The theories of optimization of the design have already been the subject of a large part of analyses in the literature.

Volume, weight and intelligent appearance requirements for many applications have led many research teams to integrate

C. B and C. B are with the National Engineering School of Gabès, MACS Research Laboratory, Gabes University, Gabes, 6029, Tunisia (phone: 216-54356158; e-mail: chokri.baccouch13@gmail.com, bahharshaymaa2018@gmail.com).

H. S. is with the National Engineering School of Gabès, MACS Research Laboratory, Gabes University, Gabes, 6029, Tunisia and with the EITA Consulting, 5 Rue du Chant des Oiseaux, 78360 Montesson, France (e-mail: saklihed12@gmail.com).

N. S. is with the EITA Consulting, 5 Rue du Chant des Oiseaux, 78360 Montesson, France (e-mail: nizar.s@eitaconsulting.fr).

photovoltaic solar cells and microwave antennas into a single multifunctional device potentially offering these many benefits [3]-[5].

In this paper, we present a hybrid structure devoted at a time to the recovery of energy and to radio frequency (RF) transmission. This miniature structure consisted in a photovoltaic cell in the grid front face which was designed to have a patch antenna adapted to the transmission band and minimize the power losses of the cell dedicated to the conversion of energy. The electrical energy received was used to operate the complete system. Our objective was mainly the optimization of the metal grid front face. The key idea behind this approach was to find the best dimensions and the electrical parameters of the metal grid to facilitate and improve the design strategy of patch antennas. The optimization adopted in this work was based on the determination of the major functions such as losses of power and conversion efficiency. These must also meet a certain set of requirements specified in the constraints [2]-[7].

As we have mentioned previously, this antenna patch ensures RF transmission. We were interested in the second part of this work in simulating this antenna; we determined the different characteristics such as reflection parameter S11, the radiation pattern, the gain and the directivity.

The photovoltaic antenna provides power to a battery-less or battery rechargeable wireless system. It stores enough energy to be able to function perspicuously. It does not require any maintenance cost and therefore enables cost and energy savings and compact design.

The rest of the paper is organized as follows. Section II presents the frequency bands for the future 5G standard. Section III describes the meshed solar cell antenna. Section IV draws the simulation results. Finally, concluding remarks are given in Section V.

II. OPTIMIZATION OF MESHED SOLAR CELL ANTENNA

In this work, we present a solar cell antenna that meets both electrical and RF needs. As shown in Fig. 1, this device transforms light into electricity to power all active circuits of the system. It provides electricity as a photovoltaic cell. The radio circuit transmits or receives data via the photovoltaic antenna. Excess energy is stored to ensure the continued operation of the wireless system when sunlight is insufficient.

A separate antenna and power source are used in older wireless systems (Fig. 2). Powering such a system is always via a battery that provides a limited power source and a limited life. The antenna is placed either inside the package or outside for RF transmission. The use of this approach to

photovoltaic antenna or solar cell antenna can meet the needs of power supply and RF transmission both without interference between the antenna and the solar cell and with the many advantages described above.

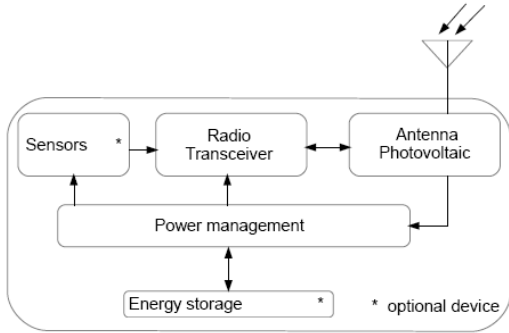

Fig. 1 Autonomous wireless system using the photovoltaic antenna

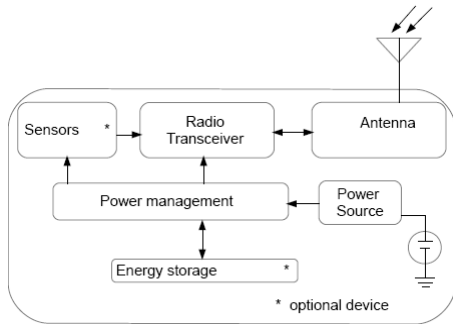

Fig. 2 Conventional wireless system block diagram

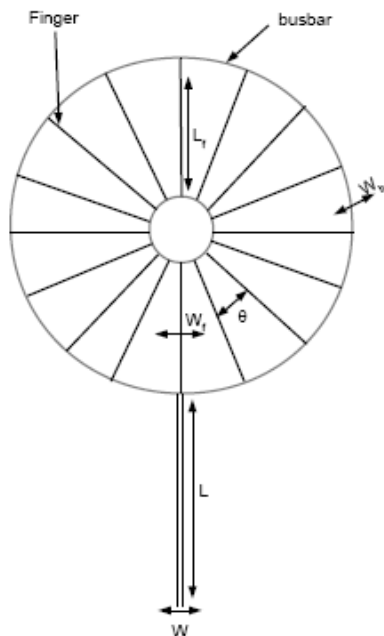

Fig. 3 Collection grid front face of a photovoltaic cell

The use of this solar cell antenna requires a smart and

miniature design, optimized to receive maximum light and to transmit or receive RF signals. The optimization of the solar cell antenna structure will be fixed on the determination of front panel collection grid dimensions as a solar cell and this grid will likewise be patch as an antenna. We proposed in this case a model whose pattern is represented in Fig. 3 which shows the geometry of the designed antenna. The dimensions of the front grid are shown in Table I.

In order to improve the conversion efficiency of the photovoltaic cell, we optimized the geometrical dimensions of the grid. An optimal design minimized the combined effect of the four mechanisms of losses directly linked to the metal grid front face. The power losses caused by each mechanism of the studied structure are given by (1)-(4) [8]-[15].

TABLE I
DIMENSIONS OF THE SOLAR CELL ANTENNA

Symbol	Values	DESCRIPTION
θ	20°	Angle
L_f	3.5 mm	Length of fingers
L	7.11 mm	Length of Inset Feed
W_b	0.5 mm	Width of bus bars
W_f	28 μ m	Width of fingers
W	0.233 mm	Width of Inset Feed

- Power dissipated of series resistance

$$P_1 = \frac{\rho_s J_{mp} L_F^2 \theta}{6V_{mp}} \quad (1)$$

- Power dissipated due to front contact

$$P_2 = \frac{\rho_m J_{mp} L_F^3 \theta}{5V_{mp} W_F} \quad (2)$$

- Power dissipated from metal resistance

$$P_3 = \frac{\rho_c J_{mp} L_F \theta}{V_{mp} W_{mp}} \quad (3)$$

- Power dissipated due to optical losses

$$P_4 = \frac{W_F L_F}{W_F L_F + L_F^2 \theta} \quad (4)$$

The total dissipated power is given by:

$$P_T = \sum_{i=1}^4 P_i \quad (5)$$

Other loss mechanisms in solar cells generally have little dependence on the selected pattern for the metal grid, and hence, are not included in the analysis [10], [11] with J_m : Surface density of current; V_m : Voltage provided by the cell; ρ_c : Resistivity of the Transmitter ($\Omega.cm$); L : Length of finger

(mm); W_f : Width of finger (cm); θ : Angle ($^\circ$); ρ_m : Resistivity of metal. ($\Omega.cm$); ρ_c : Resistivity of contact front face($\Omega.cm^2$); ρ_s : Resistance of layer of the transmitter ($\Omega.cm$); t : Thickness of metal (μm).

The power collected by the cell is written as:

$$P_{col} = P_{ecl} - P_T \quad (6)$$

with: P_{ecl} : Power of light in the cell; P_T : Total power dissipated caused by resistive losses and the shadow rate.

III. SIMULATIONS RESULTS AND DISCUSSIONS

The calculation of the resistance series without optimizing the geometrical dimensions of the collecting grid gave a high value of power collected. Hence, energy conversion efficiency decreased. The optimization of the metal grid was virtually limited to the research of the finger width W_f which resulted in the best compromise between the ohmic losses and optical losses. It sought to reduce the power of total loss. We therefore maximized the electrical power collected and this for a finger width W_f of the grid.

The used substrates are in general in multicristallin silicon. The useful parameters for the calculation of the various optical and resistive contributions of the standard cell in the front face are given in Table II. The rear face of the cell was assumed to be completely metalized with aluminum.

TABLE II
PARAMETERS USED FOR THE SIMULATION OF THE CALCULATION OF THE TOTAL LOSSES OF THE PHOTOVOLTAIC CELL IN THE FRONT FACE OF THE GRID

Symbol	Values	DESCRIPTION
θ	22.5 $^\circ$	Angle
J_m	0.03 A.cm $^{-2}$	Areal density of current
ρ_s	40 Ω/\square	Resistance of layer of the transmitter
ρ_c	5.10 $^{-5}$ $\Omega.cm$	Resistivity of contact front face
ρ_m	1.10 $^{-5}$ $\Omega.cm$	Resistivity of metal
t	7.5 μm	Thickness of metal
V_m	0.5 V	Voltage of the cell

Fig. 4 shows the variation of the power collected depending on the finger width W_f . We note that the maximum power obtained is 15.29 W/m 2 , with a yield of 17.32%, for a power of lighting 1000 W/m 2 and which corresponds to the width of a finger equal to 28 μm . This value of the width of finger was helpful in the design of patch antenna on silicon dedicated to the RF transmission.

The second step in this work was the simulation of an antenna based on the metal grid front face of a photovoltaic cell that was optimized previously. The antenna was printed on a substrate composed of different layers of silicon; a layer of n junction 0.5 μm thick and of relative permittivity $\epsilon_{r1} = 11.9$, below it a second layer p Junction 300 μm thick and $\epsilon_{r2} = 11.8$ and a third layer SiO_2 of a thickness of 1.5 mm and $\epsilon_{r3} = 3.9$ between the p layer and the ground plane.

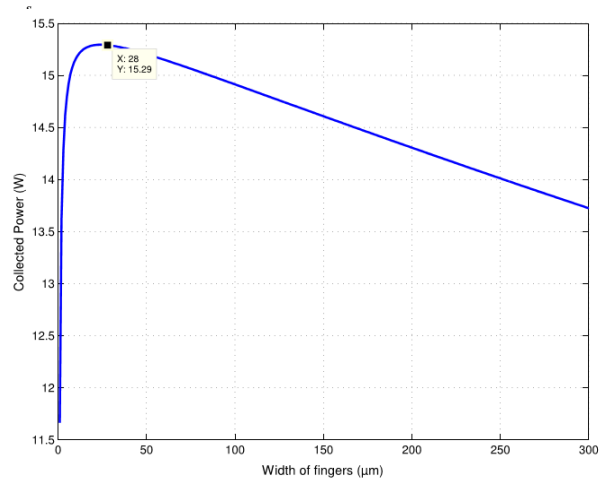

Fig. 4 Collected power according to width of fingers

The evolution of the reflection coefficient (S11) of the antenna as a function of frequency is represented in Fig. 5. This antenna radiated for a frequency of 16.55 GHz, with a bandwidth of 390 MHz.

Fig. 6 shows the radiation pattern of the antenna with a single main lobe. This antenna presented a gain of 4.24 dBi and directivity of 8.67 dB around the resonance frequency of 16.55 GHz.

The solar cell whose backside contact is excited with an RF signal is placed above a conducting ground plane. A decoupling network separates the RF from the DC current [10].

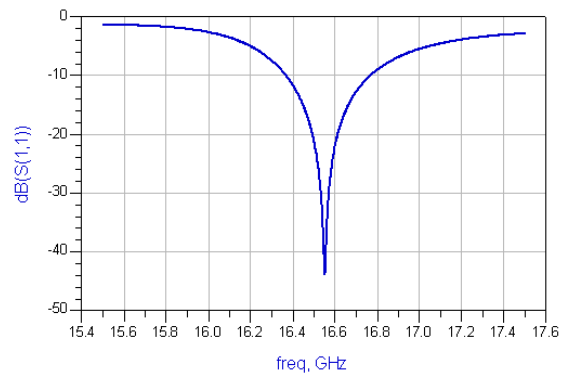

Fig. 5 Reflection parameter S11

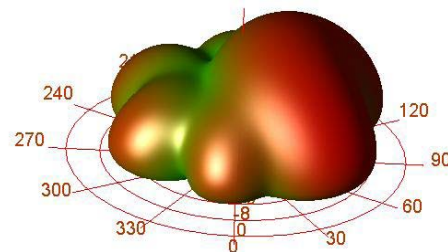

Fig. 6 Radiation pattern of the antenna

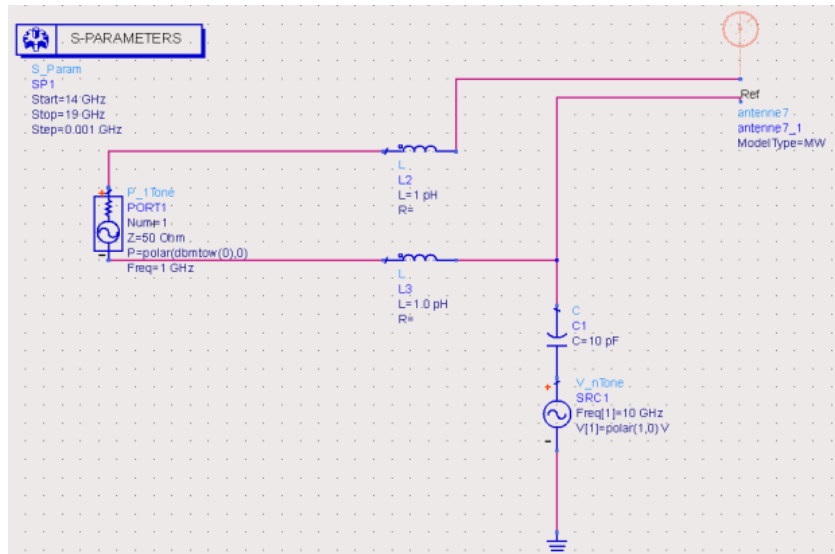

Fig. 7 Solar cell antenna decoupling RF/DC circuit

Fig. 7 shows the solar cell antenna decoupling RF/DC circuit of the patch antenna.

To date, the photovoltaic generator and the antenna are still two separate devices. They compete for the available space on mobile and standalone systems which are generally limited in size. Furthermore, they may be bulky and expensive and limit the capabilities of product designs. To overcome these restrictions a combination of antenna and solar cell in one device is desired. Thus, new design and cost reduction have become possible [16], [17].

The solar cell antenna decoupling circuit was simulated and values were compared to the reflection parameters given in Fig. 5. The plot of S11 is shown in Fig. 8.

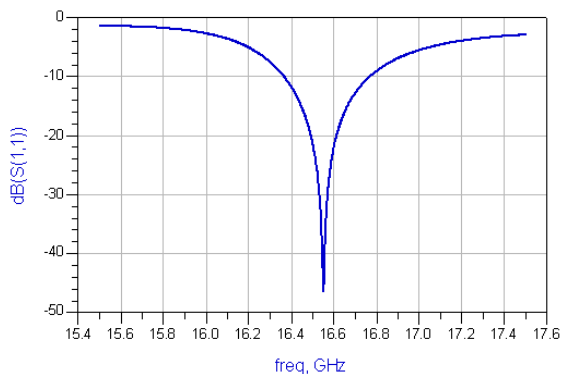

Fig. 8 Simulation of equivalent circuit

IV. CONCLUSION

In this paper we studied, in a first step, the optimization of the current collected in the grid of the photovoltaic cell to be used in the design of an antenna dedicated to the RF transmission. The optimization of the dimensions of the collection grid achieved in this paper took into account the different sources of losses. We developed a mathematical

model to optimize the dimensions of the grid. Here, the maximum power was collected for the width of finger W_F of the cell. To conclude, we managed to optimize and simulate an antenna structure based on a photovoltaic cell. This antenna is particularly well suited for the recovery of energy radiated on a wide frequency band with a very important gain totaling 4.16 dBi with a coefficient of reflection lower than -24.29 dB. This work allowed us to implement a type of patch antennas that are very beneficial and practical.

ACKNOWLEDGMENT

The authors would like to acknowledge their research laboratory for all effort made to be better at each published work.

REFERENCES

- [1] K. M. Titaouine, Analysis of Antennas Micro ruban by the model of the cavity, the model of the transmission line and the method of moments, Magister thesis University Ferhat Abbas, Sétif; 1998.
- [2] A. Taflove, and M. E. Brodwin, "Numerical solution of steady-state electromagnetic scattering problems using the time-dependent Maxwell's equations," IEEE Trans. Microwave Theory and Techniques, vol. 23, pp. 623-630, 1975.
- [3] S. J. Ammann, Mc Cormack, and B. Norton, "Integration of microstrip patch antenna with polycrystalline silicon solar cell," IEEE Trans. Antennas Propag, vol. 57, No. 12, 3969-3972, Dec. 2009.
- [4] T. W. Turpin, and R. Baktur, "Meshed patch antennas integrated on solar cells," IEEE Antennas Wireless Propag. Lett, vol. 8, 693- 696, 2009.
- [5] M. Danesh, and J. R. Long, "An autonomous wireless sensor node incorporating a solar cell antenna for energy harvesting," IEEE Trans. Microw. Theory Tech, vol. 59, No. 12, 3546-3555, Nov. 2011.
- [6] T. Bendib, F. Djeflal, "Electrical Performance Optimization of Nanoscale Double-Gate MOSFETs Using Multi-objective Genetic Algorithms," IEEE Trans on Electron Devices, vol. 58, pp. 3743-3750, 2011.
- [7] F. Djeflal, N. Lakhdar, A. Yousfi, "An optimized design of 10-nmscale dual-material surrounded gate MOSFETs for digital circuit applications," Physica E: Low-dimensional Systems and Nanostructures, vol. 44, pp. 339-344, 2011.
- [8] L. Wen, L. Yueqiang, C. Jianjun, C. Yanling, W. Xiaodong, Y. Fuhua, "Optimization of grid design for solar cells," Journal of Semiconductors,

- 31 (2010) 014006.1–014006.6.
- [10] A. Cheknane, B. Benyoucef, J.-P. Charlesb, R. Zerdoumc, M. Trarid, “Minimization of the effect of the collecting grid in solar cell based silicon,” *Solar Energy Materials and Solar Cells*, 87 (2005) 557–565.
- [11] C. Bendel, J. Kirchof, N. Henze, “Application of photovoltaic solar cells in planar antenna structures,” 3rd World Conference on Photovoltaic Energy, Osaka, Japan, May 11-18, 2003.
- [12] C. Baccouch, H. Sakli, D. Bouchouicha, T. Aguil. 2016. Patch antenna based on a photovoltaic solar cell grid collection. *Progress in Electromagnetic Research Symposium (PIERS)*.
- [13] G. Clasen, R. Langley.2004. Meshed Patch Antenna. *IEEE Transaction on Antennas and Propagation*, June, Vol. 52, No. 6.
- [14] Timothy W. Turpin.2008. Meshed Patch Antennas Integrated on Solar Cell – A Feasibility Study and Optimization. M.S. thesis, ECE Dept., USU, Logan, UT.
- [15] C. Baccouch, H. Sakli, D. Bouchouicha, T. Aguil.(2015).Optimization of the Collecting Grid Front Side of a Photovoltaic Cell Dedicated to the RF Transmission. 2nd International Conference on Automation, Control, Engineering and Computer Science ACECS, 22- 24 March 2015 Sousse, Tunisia.
- [16] P. Morvillo, E. Bobeico, F. Formisano, F. Roca, “Influence of metal grid patterns on the performance of silicon solar cells at different illumination levels,” *Materials Science and Engineering B*, 159–160 (2009) 318–321.
- [17] C. Baccouch, C.Bahar, H. Sakli, N. Sakli, T. Aguil “Design of a Compact Meshed Antennas for 5G Communication Systems” *World Academy of Science, Engineering and Technology International Journal of Electronics and Communication Engineering* Vol:13, No:11, 2019



Chokri Baccouch was born in Gabes Tunisia, in 1988. PhD in Telecommunications from the National School of Engineering of Tunis (ENIT), Tunisia. He received the National diploma in engineering Telecommunications and Networks from the National School of Engineering of Gabes (ENIG), Tunisia, in 2012.



Chayma Bahhar was born in Gabes Tunisia, in 1994. He received the M.S. degree in Electronics and Telecommunications from the Higher Institute of Computer Science and Multimedia of Gabes in 2019.



Hedi Sakli is born in Tunisia in 1966. He received the M.S. degree in High Frequency Communication Systems from Marne-La-Valley University, France in 2002, a PhD degree in 2009 and HDR degree in 2014 in telecommunications from the National Engineering School of Tunis, Tunis El Manar University, Tunisia. He is since 2010 assistant professor at the University of Gabes. He is the author of more than 30 articles. His research interests propagation in anisotropic media, Ferrite and metamaterials, numerical methods in electromagnetics and antennas.