

Investigation of Different Control Strategies for UPFC Decoupled Model and the Impact of Location on Control Parameters

S.A. Alqallaf, S.A. Al-Mawsawi, A. Haider

Abstract—In order to evaluate the performance of a unified power flow controller (UPFC), mathematical models for steady state and dynamic analysis are to be developed. The steady state model is mainly concerned with the incorporation of the UPFC in load flow studies. Several load flow models for UPFC have been introduced in literature, and one of the most reliable models is the decoupled UPFC model. In spite of UPFC decoupled load flow model simplicity, it is more robust compared to other UPFC load flow models and it contains unique capabilities. Some shortcoming such as additional set of nonlinear equations are to be solved separately after the load flow solution is obtained. The aim of this study is to investigate the different control strategies that can be realized in the decoupled load flow model (individual control and combined control), and the impact of the location of the UPFC in the network on its control parameters.

Keywords—UPFC, Decoupled model, Load flow.

I. INTRODUCTION

THE rapid demand for electrical power resulted in an extended use of the transmission system, hence driving it near to its stability limit. This created the need of an intelligent power grid where the flow of power and the system parameters are controlled. An innovative solution was presented by Electric Power Research Institute (EPRI) with the introduction of a new devices known as Flexible AC Transmission System (FACTS) controllers. These devices allow the control of the transmission system parameters (voltage magnitude, phase angle, and impedance), thus adding the flexibility and intelligence to the rigid conventional power system.

The unified power flow controller (UPFC), introduced by Gyugyi in [1], it is considered the most versatile FACTS controllers. The UPFC is capable of controlling all transmission system simultaneously. In order to evaluate the performance of the UPFC a mathematical model for the steady state and dynamic analysis should be developed.

The inclusion of UPFC in load flow studies have been rarely addressed. Few models have been developed, and the UPFC decoupled load flow model is one of the most reliable load flow models. The decoupled load flow model for the UPFC was introduced by Nabavi-Niaki and Iravani in [2]. The model proposed was the first load flow model, it had some shortcomings that were highlighted in [3], where another load

flow model was proposed based on the backbone model of the UPFC converters from [2]. Another model that used a different approach was proposed in [4], where the UPFC is modeled by a series voltage source and two shunt current sources. In [5], another approach is proposed based on the backbone model that was introduced in [2]. The model proposed was used in [6], where a detailed procedure describing the incorporation of the model in the load flow study. It has addressed a major set back of this model is that the voltage regulation capability of the UPFC is not realized and that is through setting the reactive power injection by the shunt converter to zero. Moreover, a comparison study between the three models was conducted in [7], that addressed the pros and cons of each model. In [8], another model based on the bus convention used in [2], is used with the two converters modeled in the system as PQ buses.

In [9], an investigation on the optimal installation location for UPFC for voltage regulation. The study was conducted in a single machine load bus system, where it was considered for linear and nonlinear load models. Through varying the location of installation and by varying the modulation index the reactive power injected by the shunt converter was observed, which concluded that the optimal position of installation for voltage regulation is at the sending end of the system.

The main shortcoming that was highlighted, is that the decoupled model can only be used if the UPFC is used for simultaneous control which means that active and reactive power flow and bus voltage regulation is to be controlled. Moreover, is that the another set of nonlinear equations is to be solved after the main load flow is obtained.

In this paper different control strategies for the UPFC based on the decoupled load flow model is investigated, and prove that one or two variable can be obtained with certain manipulation for the model. It also investigates the effect of location of the UPFC on the control parameters in order to see whether the location effect could lead the parameters out of their permissible range.

II. UNIFIED POWER FLOW MODELING

Consider Fig.1, which presents a schematic diagram of the unified power flow controller (UPFC). It can be seen that the UPFC is composed of two voltage source converters (VSC) connected back to back through a common dc link capacitor. The first VSC is connected in shunt to the bus of the A.C system via a coupling transformer that is termed as

S.A. Al-Qallaf Department of Electrical and Electronics Engineering, University of Bahrain, Bahrain, (e-mail: saa-1985@hotmail.com).
S.A. Al-Mawsawi and A. Haider are with University of Bahrain.

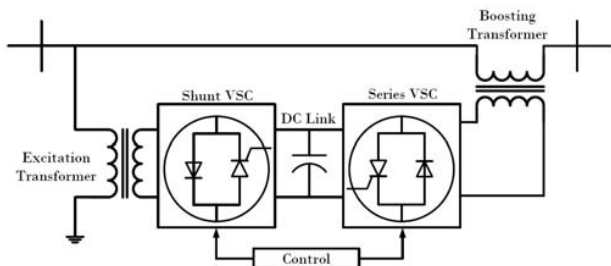

Fig. 1. Unified Power Flow Controller (UPFC) Construction

the excitation transformer. The second VSC is connected in series with the transmission line through another coupling transformer termed as boosting transformer. The UPFC is capable of controlling the power flow in the line through the injection of a controllable series voltage to the transmission line. The series voltage magnitude and phase angle are both controllable, thus it is capable to imitate the operation of TCSC to change the impedance, TCP to alter the phase angle of the sending end voltage, or even the magnitude of the sending voltage like the SSSC. The main function of the excitation converter is to supply the required active power by the boosting converter through the DC link capacitor. Thus, the total amount of active power that is exchanged between the UPFC and the AC system is always zero. Each of the VSC is capable of generating and absorbing reactive power independently, hence the UPFC is able to regulate the voltage magnitude for both of its buses.

A. UPFC Equivalent Circuit

Based on [2], it was deduced that the UPFC can modeled as can be seen from Fig.2:

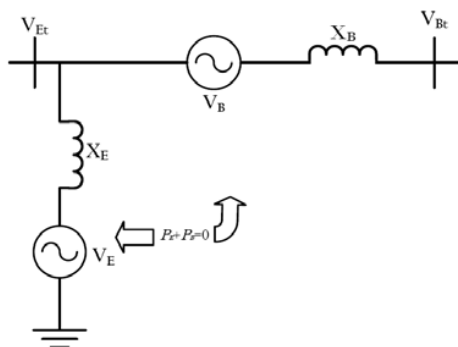

Fig. 2. UPFC Equivalent Circuit

As it can be seen that the UPFC converters are replaced by a fundamental frequency voltage sources, where the voltage magnitude and the phase angle of the voltage source are both controllable. The coupling transformers are replaced with their equivalent leakage reactance. The operation of the voltage sources is not independent of each other, rather as mentioned above that the UPFC real power constraint should be satisfied:

$$P_E + P_B = 0 \tag{1}$$

By neglecting the coupling transformers losses and by assuming that the UPFC is a lossless system, the active power injection at the UPFC buses should be equal as net active power exchange with the AC system is zero. Hence:

$$P_{Et} + P_{Bt} = 0 \tag{2}$$

B. UPFC Decoupled Model

In order to incorporate the UPFC in the load flow studies, an innovative approach was presented by [2], where the UPFC is replaced by equivalent bus representation. Hence, the power system is transformed into a conventional power system which can be solved using any load flow procedure. The bus equivalent representation of the UPFC that was presented in [2] is shown in Fig.3:

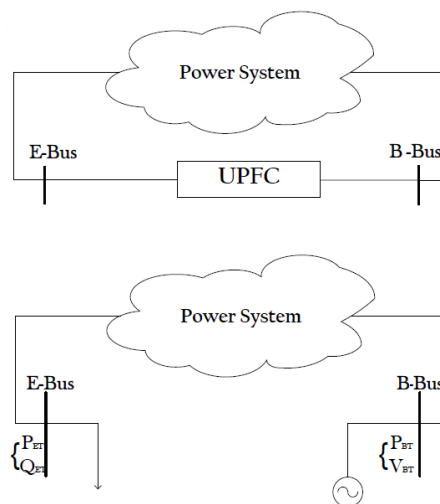

Fig. 3. UPFC Equivalent Bus Representation

In this representation the UPFC is intended for simultaneous control where it will control the active power flow through the transmission line, regulate the receiving end voltage, and control reactive power injection to the sending end bus. Hence, the sending bus is set to a PQ - load bus and the receiving end bus is set to a PV generator bus. By the assumption that the UPFC is a lossless system and from (2), it can be seen that the active power for the load bus and for the generator bus are equal and is set to the desired power flow in the transmission line that the UPFC should control. The reactive power at the load bus is the reactive power injection by the shunt converter, while the the generator bus voltage magnitude is set to the value at which the UPFC is desired to regulate.

Since in this scheme, the UPFC is intended for simultaneous control of active power flow, reactive power compensation, and bus voltage regulation. In similar manner different control schemes can be defined for simultaneous control (and with simple manipulation can be used for two or single parameter

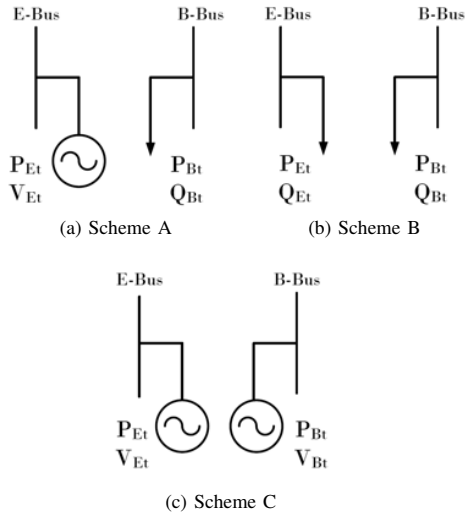

Fig. 4. UPFC Decoupled Model Different Control Schemes

control). Consider Fig.4, which is showing different control strategies using the decoupled model.

Fig.4a, shows a scheme where the UPFC is used for simultaneous control of the power flow through the transmission line and to regulate the voltage of the sending end bus. The double parameter control is achieved in scheme of Fig.4b, where the both of the buses are set as a PQ buses, where the active power can be set from (2), and by setting the injected reactive power by the shunt convert $Q_{Et} = 0$ only the active power and reactive power flow in the line is controlled. Scheme 3 is used for active power flow and voltage regulation at both buses of the UPFC.

Once the UPFC control strategy is decided, the UPFC is replace by the its bus configuration equivalent and the load flow problem is solved using any load flow procedure. Once all the state variables of the power system with the decoupled representation of the UPFC are obtained, the UPFC control parameters are to be found and in order to do this the power injections for the UPFC model in Fig.2 are given as:

$$P_{Etc} = \frac{V_{Et}V_E}{X_E} \sin(\delta_{Et} - \delta_E) + \frac{V_{Et}V_{Bt}}{X_B} \sin(\delta_{Et} - \delta_{Bt}) - \frac{V_{Et}V_B}{X_B} \sin(\delta_{Et} - \delta_B) \quad (3)$$

$$Q_{Etc} = \left(\frac{X_E + X_B}{X_E X_B} \right) V_{Et}^2 - \frac{V_{Et}V_E}{X_E} \cos(\delta_{Et} - \delta_E) - \frac{V_{Et}V_{Bt}}{X_B} \cos(\delta_{Et} - \delta_{Bt}) + \frac{V_{Et}V_B}{X_B} \cos(\delta_{Et} - \delta_B) \quad (4)$$

$$P_{Bt} = \frac{V_{Bt}V_{Et}}{X_B} \sin(\delta_{Bt} - \delta_{Et}) + \frac{V_{Bt}V_B}{X_B} \sin(\delta_{Bt} - \delta_B) \quad (5)$$

$$Q_{Bt} = \frac{V_{Bt}^2}{X_B} - \frac{V_{Bt}V_{Et}}{X_B} \cos(\delta_{Bt} - \delta_{Et}) - \frac{V_{Bt}V_B}{X_B} \cos(\delta_{Bt} - \delta_B) \quad (6)$$

And it can be seen that these equations are nonlinear, so in order to solve them Newton-Raphson method is used . The Jacobian matrix for this system of equations is found to be:

$$J = \begin{bmatrix} \frac{\partial P_{Et}}{\partial \delta_E} & \frac{\partial P_{Et}}{\partial V_E} & \frac{\partial P_{Et}}{\partial \delta_B} & \frac{\partial P_{Et}}{\partial V_B} \\ \frac{\partial Q_{Et}}{\partial \delta_E} & \frac{\partial Q_{Et}}{\partial V_E} & \frac{\partial Q_{Et}}{\partial \delta_B} & \frac{\partial Q_{Et}}{\partial V_B} \\ \frac{\partial P_{Bt}}{\partial \delta_E} & \frac{\partial P_{Bt}}{\partial V_E} & \frac{\partial P_{Bt}}{\partial \delta_B} & \frac{\partial P_{Bt}}{\partial V_B} \\ \frac{\partial Q_{Bt}}{\partial \delta_E} & \frac{\partial Q_{Bt}}{\partial V_E} & \frac{\partial Q_{Bt}}{\partial \delta_B} & \frac{\partial Q_{Bt}}{\partial V_B} \end{bmatrix} \quad (7)$$

III. STUDY SYSTEM

To investigate the impact of location of UPFC and the variation of setpoint on the control parameters, namely the modulation indexes, thus the UPFC decoupled model for different control strategy is to be implemented on a single machine infinite bus system. The system is shown in Fig.5:

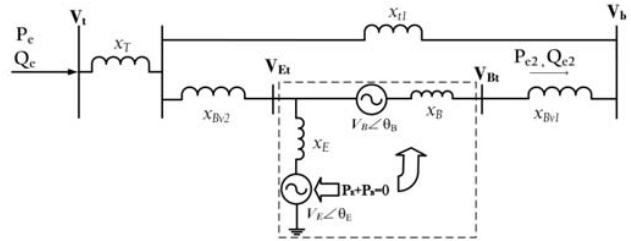

Fig. 5. Study System

For this study system the generator bus which is a PV bus where it injects an active power of 1.0 p.u and the bus voltage is being regulate at 1.05 p.u . The infinite bus has a constant voltage of $1 \angle 0^\circ$. In order to simulate the system, the UPFC is replaced by it equivalent bus model based on the control scheme to be used. So in order to study the effect of changing the setpoint on the modulation indexes different control schemes should be taken into account, in this paper two schemes are to be considered see the effect of variation of setpoint and location.

A. Case 1: PQ - PV Bus Configuration

In this scheme the UPFC is to control the active power flow in the line, regulate the voltage of the receiving end, and shunt converter is used for reactive power compensation. In this case each of the controlled variables is to be changed as the location of installation is changed while holding the other variables at a constant value.

1) Active Power : By varying the active power setpoint from 0.5 p.u to 0.65 p.u with the location, the following results were obtained:

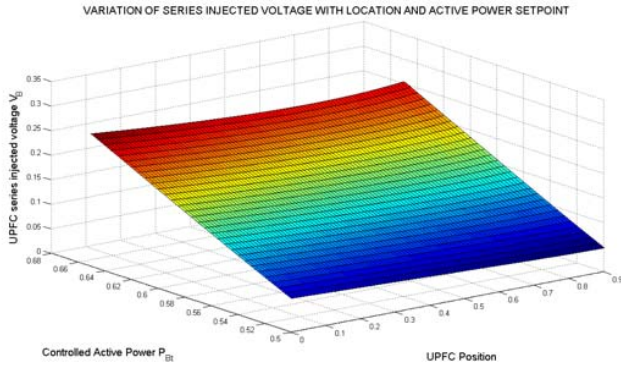

Fig. 6. Variation of series injected voltage V_B with active power setpoint and location variation

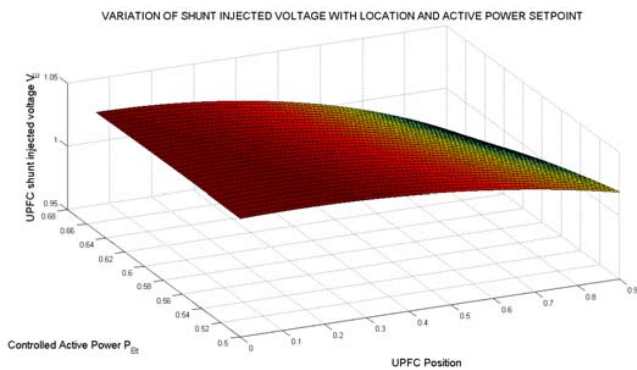

Fig. 7. Variation of shunt injected voltage V_E with active power setpoint and location variation

From Fig.6, it can be seen that the series injected voltage increases linearly with the increase in setpoint at each location. While, for a certain setpoint with the variation of location the behavior is nonlinear as can be seen. At a 0.5 p.u active power compensation, the variation of series voltage V_B seems to be linear as it drops from 0.068 p.u to 0.048 p.u as the location changes, while at higher compensation the behavior is nonlinear as the injected voltage V_B varies between 0.2691 p.u and 0.2525 p.u and the minimum is attained at 65% from the system intermediate bus. Thus the level of active power compensation is what decides the nature of the relation between the series injected voltage and the point of installation. It should be taken into consideration that there is limit to the setpoint of compensation that the UPFC can work within, which depends on the UPFC ratings.

As for the shunt injected voltage V_E , it can be seen from Fig.7 that for the UPFC connected at the intermediate bus the value is almost constant as the setpoint is varied, and that can be explained due to the change in the intermediate bus voltage V_{Et} hence the current in the shunt branch is changing. As the location is varied the injected voltage is varied, but it is almost constant for the variation in setpoint. Beyond the mid point position, the behavior of the injected voltage V_E is varied as the setpoint is varied, and it behave in a nonlinear manner as it reduces as the setpoint increase and that can be related to the increase in V_B as it should maintain the power balance

between the UPFC branches in (1).

2) *Reactive Power Q_{Et}* : Varying the shunt injected reactive power from -0.2 p.u to 0.2 p.u while all the other controlled parameters of the UPFC are kept constant, the following results were obtained:

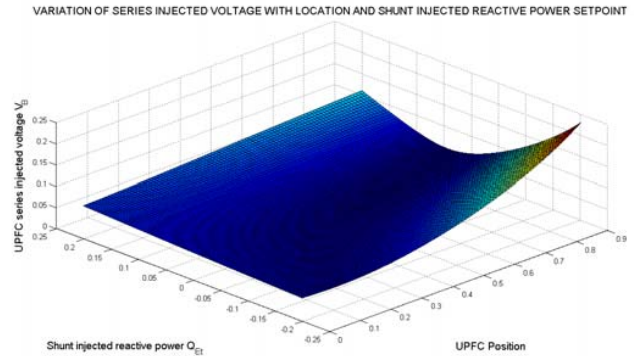

Fig. 8. Variation of series injected voltage V_B with reactive power Q_{Et} setpoint and location variation

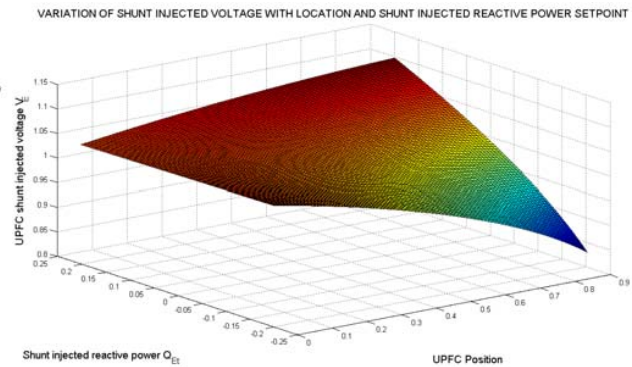

Fig. 9. Variation of shunt injected voltage V_E with reactive power Q_{Et} setpoint and location variation

From the Fig.8 and Fig.9, it can be seen that the variation in the series injected voltage V_B and the shunt injected voltage V_E are inverted from each other as it is keep the power balance of the UPFC in (1). It can be seen that the variation of the series injected voltage V_B is linear as the the variation in setpoint until 20% from the intermediate bus, after which the the variation is nonlinear as it reaches its maximum at 90% of the line as it reaches upto 0.23 p.u at $Q_{Et} = -0.2$ p.u, from this the minimum value of V_E will be at the same point.

3) *Receiving End Voltage V_{Bt}* : By varying the setpoint for the regulated receiving end bus voltage V_{Bt} , the variation in the injected voltages of the UPFC is shown in Fig.10 and Fig.11:

As can be seen from the Fig.10, that the series injected voltage V_B decreases as the voltage setpoint is increased. The behavior of V_B is as described until the UPFC reaches 75% location, where the behavior change to be come nonlinear and it starts to increase until it reaches maximum at 90% at a setpoint of 0.9 p.u. As for the shunt injected voltage V_E , it seems that as the location is getting further from the

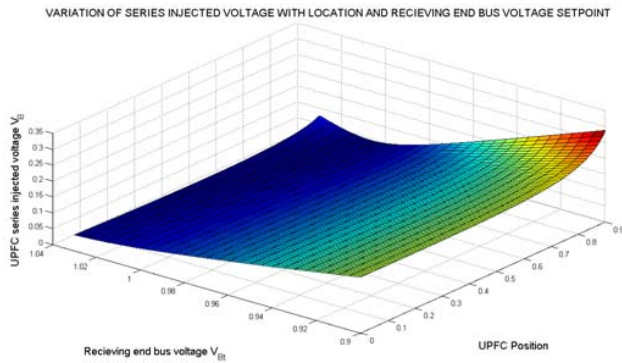

Fig. 10. Variation of series injected voltage V_B with receiving end voltage V_{Bt} setpoint and location variation

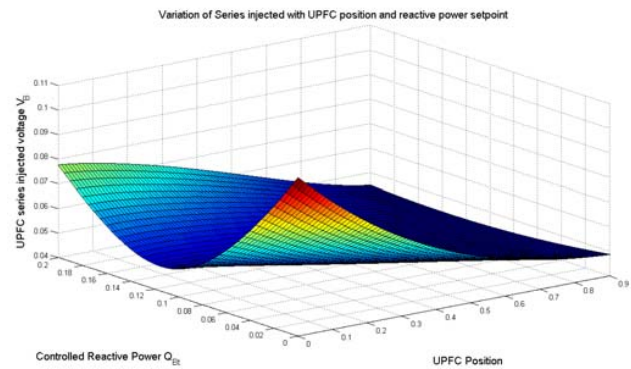

Fig. 12. Variation of series injected voltage V_B with reactive power Q_{Bt} setpoint and location variation

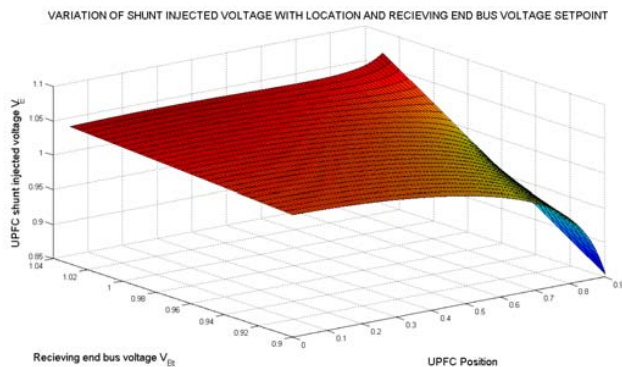

Fig. 11. Variation of shunt injected voltage V_E with receiving end voltage V_{Bt} setpoint and location variation

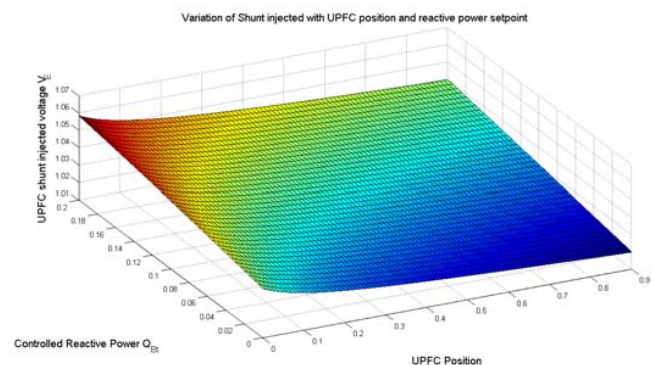

Fig. 13. Variation of shunt injected voltage V_E with reactive power Q_{Bt} setpoint and location variation

intermediate bus the behavior changes until it reaches 90% location in the transmission line, the voltage increases as the setpoint is varied. From this it can be seen that the sensitivity of the shunt injected voltage is affected by the location of installation while changing the UPFC receiving end bus voltage.

B. Case 2: PV - PQ Bus Configuration

In order to test the remaining scenarios and their effect on the UPFC control parameter, the following control scheme is to be considered where the active power and reactive power of the line are controlled as well as regulating the sending end voltage. Since the effect of active power variation with the location of installation was presented before, it will not be considered here and the rest of the cases are considered.

1) *Reactive Power Q_{Bt}* : In this case the controlled reactive power Q_{Bt} setpoint is varied in order to investigate the impact of the injected voltage, and by varying the location of installation of the UPFC it is going to be shown how does it affect the control parameters. By varying the reactive power from 0 p.u up to 0.2 p.u, the results that were obtained in Fig.12 and Fig.13.

Fig.12, it can be seen that the series injected voltage V_B sensitivity to the variation in reactive power Q_{Bt} decreases as the location of the installation of the UPFC is getting further

near to the infinite bus. As the distance increases the variation in V_B becomes less, at $x = 0$ the injected voltage value swings between 0.1 p.u and 0.05 p.u, and the variation can be seen as a nonlinear relation. But, at $x = 0.9$ it can be seen that the variation is small as it changes between 0.048 p.u and 0.045 p.u. As for the shunt injected voltage V_E , the variation is linear with the setpoint variation. The variation with the location of the UPFC did not effect the behavior of the V_E with the variation in Q_{Bt} .

2) *Sending End Voltage V_{Et}* : by changing the setpoint of the regulated voltage V_{Et} for the sending end of the UPFC, while changing the location where the UPFC is installed resulted in the following variation in the injected voltages that is shown in Fig.14 and Fig.15.

The series injected voltage V_B sensitivity decreases as the location of installation gets further from the intermediate bus, and that is the reverse in the shunt injected voltage V_E as it becomes more sensitive to the variation of location. The sensitivity of V_B is less compared to V_E , as the variation of V_B with the location can be seen from the slope $\frac{dV_B}{dV_{Et}}$ that did not much vary.

IV. CONCLUSION

The decoupled model for the UPFC has been upgraded for different control schemes that can be modified for

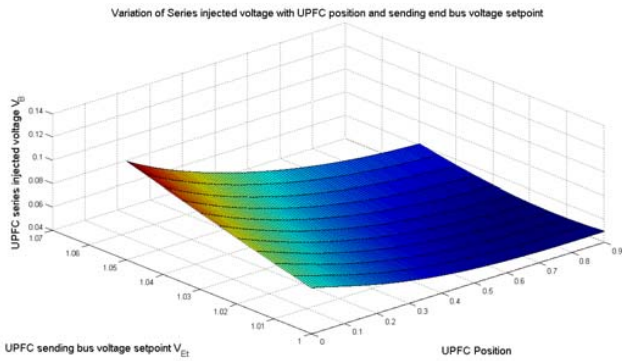

Fig. 14. Variation of series injected voltage V_B with sending end voltage V_{Et} setpoint and location variation

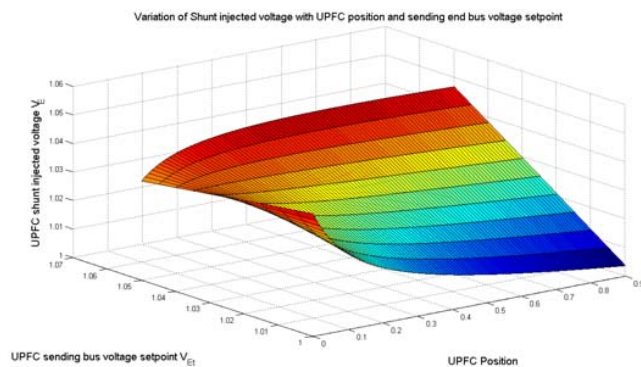

Fig. 15. Variation of shunt injected voltage V_E with sending end voltage V_{Et} setpoint and location variation

simultaneous control or single control with the manipulation of the setpoints for the injected powers in the bus equivalent model of the device. To measure the sensitivity of the UPFC control parameters, namely the injected voltages of the UPFC, varying the setpoint of the controlled parameters individually, one at a time, with the variation of the location where the UPFC is installed. It was shown that regardless of the controlled variable the variation of the injected voltages is the inverse of each other and that is to keep the active power exchange between the UPFC and the system at zero. Also, the control scheme has an impact on the sensitivity of the control parameters of the UPFC. The sensitivity of the injected voltage depends on the controlled variable and the location, and it was found that as the distance increases from the system intermediate bus the sensitivity increases except in case of line reactive power control. From this it can be seen that the effect of position on the controlled parameters of the UPFC is significantly affected by the location of installation. However, this will only be visible if the limits of UPFC injected voltages is considered and that by considering the ratings of the UPFC series and shunt converters.

REFERENCES

[1] L. Gyugyi, "Unified power-flow control concept for flexible ac transmission systems," in *IEE Proceedings C (Generation, Transmission and Distribution)*, vol. 139, no. 4. IET, 1992, pp. 323–331.

- [2] A. Nabavi-Niaki and M. Iravani, "Steady-state and dynamic models of unified power flow controller (upfc) for power system studies," *Power Systems, IEEE Transactions on*, vol. 11, no. 4, pp. 1937–1943, Nov 1996.
- [3] C. Fuerte-Esquivel, E. Acha, and H. Ambriz-Perez, "A comprehensive newton-raphson upfc model for the quadratic power flow solution of practical power networks," *Power Systems, IEEE Transactions on*, vol. 15, no. 1, pp. 102–109, Feb 2000.
- [4] S.-H. Lee, C.-C. Chu, and D.-H. Chang, "Comprehensive upfc models for power flow calculations in practical power systems," in *Power Engineering Society Summer Meeting, 2001*, vol. 1. IEEE, 2001, pp. 27–32.
- [5] M. Noroozian, L. Angquist, M. Ghandhari, and G. Andersson, "Use of upfc for optimal power flow control," *Power Delivery, IEEE Transactions on*, vol. 12, no. 4, pp. 1629–1634, 1997.
- [6] A. Vural and M. Tumay, "Steady state analysis of unified power flow controller: mathematical modeling and simulation studies," in *Power Tech Conference Proceedings, 2003 IEEE Bologna*, vol. 4. IEEE, 2003, pp. 6–pp.
- [7] M. Z. El-Sadek, A. Ahmed, and H. E. Zidan, "Comparison of unified power flow controller models for power flow studies," in *Power Systems Conference, 2006. MEPCON 2006. Eleventh International Middle East*, vol. 1, Dec 2006, pp. 189–196.
- [8] N. M. Santos, V. M. Pires, and R. M. Castro, "A new model to incorporate unified power flow controllers in power flow studies," in *Transmission and Distribution Conference and Exhibition, 2005/2006 IEEE PES*. IEEE, 2006, pp. 133–140.
- [9] S. A. Al-Mawsawi and M. Qader, "Comparison of optimal location of upfc applied to linear and non-linear load model," in *AC and DC Power Transmission, 2006. ACDC 2006. The 8th IEE International Conference on*. IET, 2006, pp. 204–209.



S.A. Alqallaf received B.Sc. in Electrical and Electronics Engineering from University of Bahrain. Currently working towards the M.Sc. degree in Electrical Engineering. Research interests are in Power system dynamics and control, power electronics applications in power systems, and evolutionary optimization.

S.A. Al-Mawsawi received the B.Sc. (F. Hons) degree from University of Bahrain, Bahrain, in 1988 and the M.Sc. from University of Bradford and Ph.D. degree from Imperial College, London, UK, in 1995, all in Power Electronics Engineering. He is currently with the University of Bahrain. His research interest includes power electronics, FACTS devices and control applications.

A. Haider received the B.Sc. (F. Hons) degree from University of Bahrain, Bahrain, in 1988 and the M.Sc. from University of Bradford in 1990. He earned his Ph.D. degree from UMIST, UK, in 1996, in Control Systems Engineering. He is currently with the University of Bahrain.