

Influence of Static Pressure on Viability of Entomopathogenic Nematodes – *Steinernema feltiae*

J. Chojnacki, E. Dulcet, A. Grieger

Abstract—The entomopathogenic nematodes *Steinernema feltiae* are components of many biological pesticides. The biological pesticides are applied by means of spraying machines. The influence of high pressure operating time on viability of nematodes has been experimentally investigated in order to explain if static pressure inside of the sprayers installation was able to destroy nematodes. The value of pressure was 55 MPa and its maximum operating time was 3 hours. Changes were found in viability of pressurized samples of nematodes, mixed with water.

Keywords—Entomopathogenic nematodes, biopesticides, high pressure, sprayer.

I. INTRODUCTION

ENTOMOPATHOGENIC nematodes are a component of many biological pesticides used in plant protection, specifically in organic agriculture [1]. Nematodes are effective in destroying the larval insects both in soil as well on plants. Dimensions of nematodes depend on their species. They are 0.5–1.45 mm in length and 0.018–0.046 mm in width [2]. Such small sizes allow nematodes mixed with suspension liquid, which is mostly water, to be applied into plant community by means of spraying machines. It was found that these machines at some variables of a process partly contribute to the death of nematodes [3],[4]. Degradation of nematodes may result from exceeding the permissible limits of stresses in liquid, inside installations of spraying machines, for their survival [5]. Pressure of liquid used for spraying machines during application of pesticides may reach the value up to 2000 kPa [6]. The total pressure of liquid consists of static pressure and dynamic pressure. The static pressure causes the nematodes included in the liquid to be compressed. The dynamic pressure brings about a flow of fluid at high

velocities through installation elements such as a pump, valves, mixer and spray nozzles. Entomopathogenic nematodes flowing through spraying machines are affected by action of both the types of pressure. One may assume that putting the static pressure on the body of nematodes after exceeding some limits would cause their death [5].

High pressure could be fatal for macro- and microorganisms. It is used for killing the parasites in food goods [7]. Food being subjected to high pressure from 100 to 1000 MPa could be sterilised. By making use of high pressure it is possible to destroy nematodes included in meat, which after consumption of infected meat may become dangerous human parasites. Nematodes *Trichinella spirali* included in pork were subjected to pressure amounting to 200 MPa [8]. Operation time of pressure exerted on meat specimens was fluctuating within 10 – 30 min, and the value of temperature was changing during experiments from 5 to 25°C. Nematodes *Trichinella spirali* under these conditions were killed. Larvae of nematodes *Anisakis simple* included in mackerel caught in the North Sea were annihilated in a similar way [9]. Fresh fish was subjected to the pressure of 300 MPa for 5 minutes which caused 100% of larvae included in fish to be annihilated.

Similarly the high pressure sterilizes bacteria and their spores. The effectiveness of the adverse effect on bacteria could be increased by raising the temperature [10]. The fatal effect of high pressure in relation to micro and macro organisms is difficult to be explained. Probably it is connected with morphological changes in cells (deformation and changes in plasma membrane structure, changes in nuclei) [11], [12]. The adverse effect of high pressure is also connected with its influence on proteins, enzymes and polysaccharides [13].

Technologically, it is possible for high pressure to be obtained by two methods: a direct system – by compressing the product with a piston, and an indirect system – by pumping the liquid into a pressure chamber filled with foot. The application of the direct method may additionally contribute to failure of pressed products due to direct, mechanical contact with a piston.

The main purpose of the presented experiment was to check whether static pressure is able to destroy entomopathogenic nematodes *Steinernema feltiae* in spraying machines. Additionally the experiments were aimed to investigate if high values of static pressure exerted an influence on viability of

Jerzy Chojnacki is with the Department of Agriculture Engineering, Koszalin University of Technology, Koszalin, Raclawicka 15-17, Poland, phone: +48 943478359; fax: +48 943426753; (e-mail: jerzy.chojnacki@tu.koszalin.pl).

Edmund Dulcet is with the Department of Agriculture Engineering, University of Technology and Life Sciences, Bydgoszcz, Kaliskiego 7, Poland, phone: +48 523408481; fax: +48 523408481; (e-mail: dulcet@utp.edu.pl).

Andrzej Grieger is with the Department of Agriculture Engineering, Koszalin University of Technology, Koszalin, Raclawicka 15-17, Poland, phone: +48 943478261; fax: +48 943426753; (e-mail: angri@szczecin.home.pl).

larval nematodes.

II. MATERIALS AND METHODS

Invasive larvae of nematodes (*Steinernema feltiae*), that find application as biological pesticide against sciarids were biological material being tested. Nematodes included in a plant pesticide named Steinernema System were purchased from its manufacturer Biobest NV. Nematodes designed for testing were mixed with water. The concentration of nematodes in liquid was 10 000 larvae per 1 ml.

The viability of nematodes that was determined as relative viability on the basis of liquid specimens was obtained by solving the following formula:

$$V_r = \frac{N_l}{N_t} \cdot 100 \% \quad (1)$$

Where:

- V_r – relative viability %,
- N_l – number of living nematodes,
- N_t – total number of nematodes.

The number of living nematodes and the total number of nematodes were counted using a microscope. Only these nematodes, which after touching them with a surgical needle did not respond to the touch, were considered as dead. Six samples from each liquid specimen used for testing were taken for repetition of nematodes counting.

Nematodes were subjected to static pressure in a specially designed experimental device. The experimental device was connected up to where high pressure of water was produced. The hydraulic installation consisted from a pump driven by electric motor and overflow valve for pressure control. The pump was continuously supplied with water at the temperature of 18°C. The construction of the device is presented in Fig. 1.

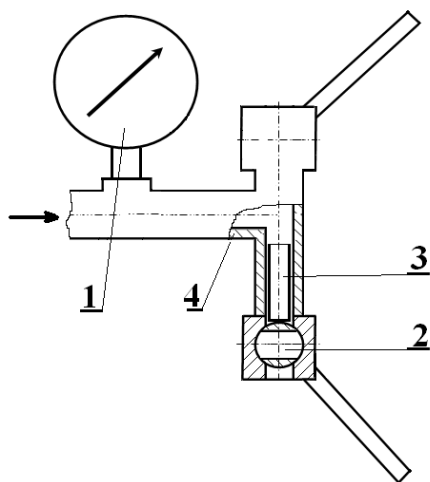

Fig. 1. Experimental device; 1 – manometer, 2 – ball valve, 3 – sampler with nematodes, 4 – pipe

It consists of ball valves enabling a sampler with nematodes to be put in and taken out and a manometer to the

pressure control. The sampler with nematodes, which was inserted into an experimental device, was open from top, thus liquid being under pressure could directly act on the liquid with nematodes situated in a sampler. Due to such construction of an experimental device it was possible to eliminate movable mechanical elements e.g. pistons or valves affecting nematodes that could additionally destroy larvae under test. The pressure applied in experiments was equal to 55 MPa. Such a high value of pressure under test, compared to the value of pressure applied to liquid in spraying machines was established considering a weak expected influence of the pressures used for spraying on the viability of nematodes. Times of pressure treatment accepted for experiments were much larger than times when nematodes were in spraying machines under higher pressure. Nematodes times of treatment in test were established for 0.5; 1.0; 2.0 and 3 hours. Each time was corresponding to other specimen. Additionally a counter-specimen with nematodes not treated to pressure was prepared. Then all specimens with nematodes were kept for 24 hours at a temperature of 18°C. This time was established in such a way that nematodes which were negatively affected by pressure but had not died could immediately be destroyed. After this time an analysis of nematodes' viability in all tests was carried out.

III. RESULTS

The results are presented in Fig. 2. The results were subjected to statistically ANOVA in order to determine the significance of influence of the time of pressure treatment on relative viability of nematodes.

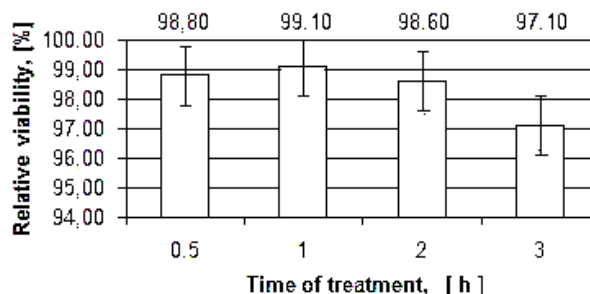

Fig. 2. Influence of the time of pressure treatment on nematodes relative viability

There was calculated significance level, which value was 0.0436. At this value of significance level, lower than 0,05 the Least Significant Difference (LSD) was 1.397%. It results from an analysis of variance that the time had a significant influence on relative viability of nematodes. The factor, which value significantly differed from the others was the value of relative viability obtained after 3 hours of keeping nematodes *Steinernema feltiae* under pressure of 55 MPa.

The obtained changes in values of relative viability of nematodes indicate the large resistance to such high pressure and one may assume that significantly lower pressure of liquid, which may occur in a spraying machine and the time of

its operation while spraying are not able to put nematodes *Steinernema feltiae* to death.

IV. CONCLUSIONS

A significant influence of time on changes in relative viability of nematodes *Steinernema feltiae* subjected to static pressure exerted by liquid at the value of 55 Megapascals was revealed, however these changes did not exceed 2% after 3 hours.

Static pressure inside installation of a spraying machine even reaching as far as 2 MPa is not able to destroy nematodes *Steinernema feltiae* during spraying. Establishing to the experiments the static pressure 55 MPa was too little to be able to destroy nematodes completely. Entomopathogenic nematodes are peoples' friendly living organisms, therefore completely destruction them was not the aim of the experiment

REFERENCES

- [1] P.S.Grewal, R.U.Ehlers, D.I Shapiro-Ilan. *Nematodes as Biocontrol Agents*. CAB International, 2005.
- [2] G.O. Poinar Jr., Biology and Taxonomy of Steinernematidae and Heterorhabditidae. In:Gaugler, R., Kaya, H.K. (Eds.), Entomopathogenic Nematodes in Biological Control. CRC Press, Boca Raton, FL, 1990, pp 23-62.
- [3] U. Nilsson, E. Gripwall, . Influence of Application Technique on the Viability of the Biological Control Agents *Verticillium lecanii* and *Steinernema feltiae*. *Crop Protection* 18(1), 1999, pp 53-59.
- [4] J. Chojnacki. Śmiertelność nicieni w obiegu hydraulicznym opryskiwacza. *Inżynieria Rolnicza*. Nr 3 (91), 2007, pp 45-50.
- [5] J. P. Fife, R. C. Derksen, H. E. Ozkan, P. S. Grewal. Effects of pressure differentials on the viability and infectivity of entomopathogenic nematodes *Biological Control* 27. 2003, pp 65–72.
- [6] D. I. Shapiro-Ilan, D. H. Gouge, S. J. Piggott, J. P. Fife. Biological Application technology and environmental considerations for use of entomopathogenic nematodes in biological control *Control* 38. 2006, pp 124–133.
- [7] E. Hać-Szymańczuk, J. Mroczek. Zastosowanie techniki wysokich ciśnień w technologii żywności, a szczególnie w przetwórstwie mięsa. *Medycyna Wet.* 62 (6). 2006, pp 637-640.
- [8] K. Nöckler, V. Heinz, K. Lemkau, D. Knorr: Inaktivierung von *Trichinella spiralis* in Schweinefleisch durch Hochdruckbehandlung. *Fleischwirtschaft* 82. 2001, pp 85-88.
- [9] A. Brutti, P. Rovere, S. Cavallero, S. D'Amelio, P. Danesi, G. Arcangeli. Inactivation of *Anisakis simplex* larvae in raw fish using high hydrostatic pressure treatments. *Food Control* 21. 2010, pp 331–333.
- [10] M. F. Patterson, M. Quinn, R. Simpson, A. Gilmour: The sensitivity of vegetative pathogens to high hydrostatic pressure treatment in phosphate buffered saline and foods. *J. Food Prot.* 58. 1995, pp 524-529.
- [11] L. I. Dehne, M. K.-H. Pfister, K. W. Bogl: Verfahren zur Haltbarmachung. *Fleischwirtschaft* 81. 2000, pp 41-45.
- [12] D. Drobisz-Kopydłowska: Wpływ wysokich ciśnień na żywność. XLII Międzynarodowy Kongres Nauki o Mięsie i Technologii w Lillehammer. *Gosp. Mięsna* 49. 1997, pp 32-33.
- [13] J. C. Chefel, J. Ciulioli: Effect of high pressure on meat: a review. *Meat Science.* 46. 1997, pp 211-236