

Implementation of Renewable Energy Technologies in Rural Africa

J. Levodo, A. Ford, I. Chaer

Abstract—Africa enjoys some of the best solar radiation levels in the world averaging between 4-6 kWh/m²/day for most of the year and the global economic and political conditions that tend to make African countries more dependent on their own energy resources have caused growing interest in renewable energy based technologies. However to-date, implementation of modern Energy Technologies in Africa is still very low especially the use of solar conversion technologies. This paper presents literature review and analysis relating to the techno-economic feasibility of solar photovoltaic power generation in Africa. The literature is basically classified into the following four main categories. Techno-economic feasibility of solar photovoltaic power generation, design methods, performance evaluations of various systems and policy of potential future of technological development of photovoltaic (PV) in Africa by exploring the impact of alternative policy instruments and technology cost reductions on the financial viability of investing solar photovoltaic in Africa.

Keywords—Africa Solar Potential, Policy, Photovoltaic, Technologies.

I. INTRODUCTION

THE development of renewable energy sources is necessary for the sustainable development of any country due to depleting fossil fuel level, climbing fossil fuel prices across the world and more recently pressure for reduction emission level. Among various renewable energy sources based technologies, the photovoltaic technology for power generation is considered well-suited technology particularly for distributed power generation in rural Africa as the level of solar radiation average is between 4-6kW/m²/day. The large introduction of PV systems may replace or postpone the extension of conventional central stations of electricity production and the investment in grid reinforcement having a positive overall economic impact. The PV system electric power is of particular value when it coincides with the peak demand, solar photovoltaic (SPV) systems can also increase the reliability of the system to which they are connected, can also reduce transmission and distribution losses as they

generate the electricity close to the point where it is consumed. Renewables are often recommended as the most appropriate energy technology choice for much of african countries. This paper presents the literature review of the techno- economic analysis of solar photovoltaic power generation. This paper is organized as follows: In Section I, review of the techno-economic feasibility of solar photovoltaic power generation is presented. Design methods in Section II, Performance evaluations of various systems are discussed in Section III. Policy of potential future of technological of photovoltaic (PV) in Africa in Section IV and a conclusion followed by the references is presented in Section V.

II. TECHNO-ECONOMIC FEASIBILITY OF SOLAR PHOTOVOLTAIC

The assessment of a particular energy system for its techno-economic feasibility is of almost importance if the system has to function satisfactorily at a given location. The techno-economic feasibility assessment of a particular technology begins with evaluating the technological appropriateness, economic viability and other financial incentives of a technology for it to get successfully disseminated at a given location. This section deals with the literature pertaining to the techno economic evaluation of various solar photovoltaic systems. The economic competitiveness of PV systems in developing countries and showed that even after including externality costs, the economics of PV applications are unlikely to allow for an unsubsidized, wide spread adoption of this technology in the near future without significant technological breakthroughs [1]. In this work it is concluded that solar photovoltaic systems require further research and development programmes for the improvement in PV panel efficiencies. The techno-economic assessment of an autonomous hybrid PV/diesel for a tourist has been done [2]. The different economic and financial aspects have also been calculated for different financial scenarios and concluded that the use of solar energy supply systems imply no compromise for the tourists in terms of comfort, reliability of operation and facilities compared with conventional lodging and renewable systems are mature technologies and provide alternative solutions to the increasing global energy-demand problem [3]. Techno-economic viability of hybrid photovoltaic diesel battery power systems for residential loads in Saudi Arabia has been presented [4].

J. Levodo is a PHD Student in the School of the Build Environment and Architecture at London South Bank University, 103 Borough Road SE1 0AA UK (phone: +44(0)2078157105; e-mail: levodoj@lsbu.ac.uk).

A. Ford is a Professor in Systems Engineering in the School of the Build Environment and Architecture at London South Bank University, 103 Borough Road SE1 0AA UK (phone: +44(0) 20 7815 7160; e-mail: andy.ford@lsbu.ac.uk).

I. Chaer is a Reader and Course Director in the School of the Build Environment and Architecture at London South Bank University, 103 Borough Road SE1 0AA UK (phone: +44(0) 020 7815 7149 e-mail: chaeri@lsbu.ac.uk).

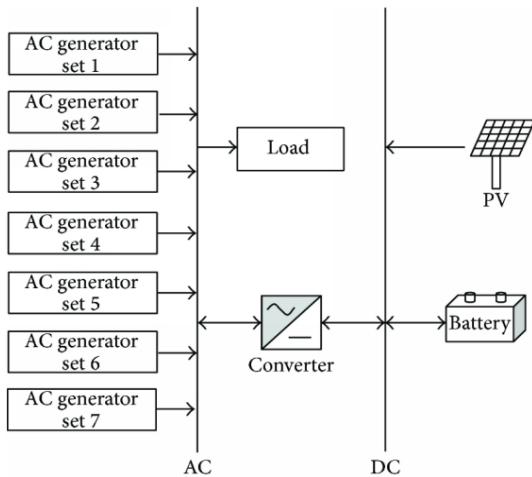

Fig. 1 Configuration of hybrid PV/diesel/battery power system [34]

The analysis highlights several benefits of the hybrid system. Some of these are high utilization rate of PV generation; optimal satisfaction of load; maximum diesel efficiency with minimum maintenance; reliable power supply; and a reduction in the capacities of PV, diesel and battery while matching the peak loads. Emphasis has been placed on a load, excess electricity generation, percentage fuel savings and reduction in carbon emissions for different scenarios such as PV diesel without storage, PV diesel with storage, as compared to diesel-only situation. The decrease in carbon emissions by using the above hybrid system is about 24% as compared to the diesel only scenario. The economic viability of a standalone PV system in comparison to the most likely conventional alternative system, i.e. a diesel powered system, has been analysed for energy demand through sensitivity analysis [5]. The analysis shows that PV-powered systems are the lowest cost option at a daily energy demand of up to 15 kWh, even under unfavourable economic conditions. When the economic parameters are more favourable, PV-powered systems are competitive up to 68 kWh/day. These comparisons are intended to give a first-order indication of when a stand-alone PV system should be considered for application. As the cost of PV systems decreases and diesel costs increase, the break- even points occur at higher energy demand storage tanks become full; the excess power will be diverted to another dump load. When there is a deficit in power generation production is presented [6]. Briefly, the most important results of the analysis are the calculation of a gross energy requirement (GER) of 1494 MJ/panel (0.65 m² surface) and of a global warming potential (GWP) of 80 kg of equivalent CO₂ panel. The energy payback time (EPBT) has been estimated to be shorter than the panel operation life even in the worst geographic conditions. The results of the LCA support the idea that the photovoltaic electric production is advantageous for the environment. The foreseeable technological advancements in current and emerging PV technologies over the next few decades are likely to lead to significantly lower per-kWh impact than the one that characterizes the current state of the art of the PV sector has

been analysed [7]. A complete techno-economic analysis of standalone solar photovoltaic system has been presented [8]. In this work, complete analytical methodology for optimum relationship between PV array and storage battery capacity to supply the required energy at a specified energy load fraction is carried out. To estimate the performance of solar photovoltaic system the solar radiation utilizability concept and the monthly average daily PV array efficiency have been used. The techno economic optimization of a PV system has been done by using levelized energy cost computation based on the total number of battery replacements (brp's) through battery life cycle model. It has been found that energy load fractions as well as the number of brp's have a significant impact on the selection of optimum sizing of a stand-alone PV system. From the techno-economic and environmental points of view, the feasible sites in Egypt to build a 10 MW PV-grid connected power plant and recommended few sites for large scale PV power generation [9]. The techno-economic analysis of grid connected hybrid wind/PV system is carried out for three different locations in Iraq [10], and it was observed that total amount of energy generated from wind and solar is highest for one location and less for the rest of two and it is concluded that in case of solar and wind plant location strongly affect the plant performance. Authors have performed a net present value comparison for north Cameroon between Photovoltaic hybrid system for mini grid application, standalone photovoltaic and standalone diesel generator options for a typical energy demand [11]. A complete techno-economic comparison of rural electrification based on solar home systems and PV micro grids to supply electricity to rural community for domestic purpose has been performed [11]. Based on study it is concluded that a micro grid might be a financially more attractive option for the user, energy service company and the society if the village has a large number of households, is densely populated and lies in a geographically flat terrain and more than 500 densely located households using 3-4 low power appliances (e.g. 9 W CFLs) for an average of 4 h daily. However, in rough terrains solar home systems might be a better option if the community is small and sparsely populated. The economic analysis has been performed on the grid connected SPV system connected to the Spanish grid [12]. Using net present value (NPV) and payback period (PP) parameters, the profitability of the system was studied. The system was evaluated for its economic as well as environmental benefits and the results clearly showed that the system is profitable enough to be invested in, but very long pay back periods were dissuading the investors. It has been concluded that there is no way one can afford to ignore assessment of the systems for their techno-economic feasibility as these parameters are location specific and the successful operation of the systems entirely depend on these parameters at a given region. It is also observable that systems which are uneconomical for a given load factor may become feasible for higher load factors. This opens up the discussion on what should be the ideal size, capacity factor and load factor range for which the system becomes feasible. Some of these questions were answered in the literature using

optimization models. But it acts as a background for the design of the systems, which will be discussed in another section namely Design Methods.

III. DESIGN METHODS

The technical design of a system refers to design of correct sizing of the system with respect to capacity, optimal design for increased reliability and improvements in efficiency. The main objective of design of the system is to improve the quality of power for a given load factor and to achieve this in an optimal way. This depends on parameters like the population, demand, and proximity to grid. There is a huge knowledge base available in studies of design of the SPV systems. Different techniques like optimization, simulation and other mathematical modeling tools have been used for this purpose and are discussed.

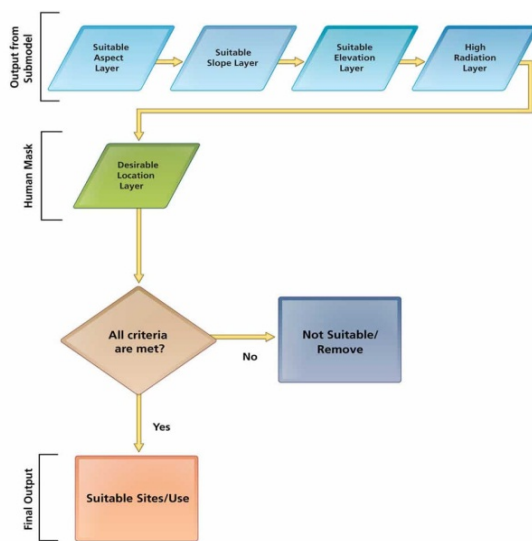

Fig. 2 Flowchart showing the selection process of a design method [35]

Literature presents the methods for component selection and system design. A review of different methods for sizing photovoltaic systems indicates that they fall into mainly two categories, analytical methods and simulation based schemes. A methodology for the calculation of optimum size of a battery bank and optimum size of a Photovoltaic (PV) array in a hybrid wind/PV system for a given level of reliability of a typical house in Massachusetts is developed [12] and for a given load and a desired Loss of Power Supply Probability, an optimum number of batteries and PV modules was calculated based on the minimum cost of the system. The possibility of wind alone, PV alone and hybrid wind/PV system for a typical residential load in Montana is discussed [13]. Generation and storage units for different system are properly sized in order to meet the annual load and minimize the total annual cost to the customer. In addition, an economic analysis has been performed for the three different scenarios and is used to justify the use of renewable energy versus constructing a line

extension from the nearest existing power line to supply the load with conventional power. Annual average hourly values for load, wind speed, and insolation have been used.

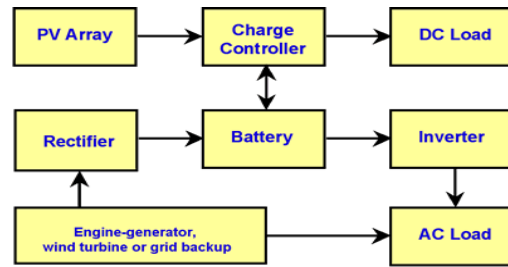

Fig. 3 Schematic diagram of standalone hybrid PV-wind system [36]

This work takes into account the economic factors for calculation of optimum component size. In this paper, an economic analysis is performed for realizing the advantage of the stand-alone system versus constructing a line extension from the nearest existing distribution line for supplying the load with conventional power. The sizing and techno-economic optimization of an autonomous hybrid PV/Wind energy system with battery storage is discussed [14]. The study has considered the various aspects e.g. the level of autonomy i.e. the fraction of time for which the specified load can be met and the cost of the system rather than designing the system for the worst month scenario which lead too costly system as done by few researchers the system cost and performance both are taken into account and a third energy source that is a battery is connected in the system to reduce the cost. A method for designing the PV power system respecting the local environmental conditions is discussed [15]. The results of the measurements carried out over two years show the extent to which PV power generation can be matched with load demands and state of battery charge even during periods of low solar radiation. For Ethiopian conditions a method is investigated to find the possibility of supplying electricity from a solar-wind hybrid system to a remotely located model community detached from the main electricity grid. Based upon the solar and wind energy potential feasibility study has been carried out on how to supply electricity to a model community of 200 families, which comprises 1000 people in total. A software tool, Hybrid Optimization Model for Electric Renewables (HOMER) is used for the analysis. The result of the analysis is a list of feasible power supply systems, sorted according to their Net Present Value. Furthermore, sensitivity diagrams, showing the influence of wind speeds, PV costs, and diesel prices on the optimum solutions are also provided [16]. In one of the study a generalised methodology based on a time series simulation approach for generating a “sizing curve” relating the generator rating and storage capacity is presented [17]. This methodology helps the identification of a design space that explores all feasible system configurations meeting a given demand for a site. It further serves as a tool for system optimization. Using this same approach a methodology for the optimum sizing of photovoltaic battery system for remote electrification incorporating the uncertainty

associated with solar insolation is presented [17]. The sizing curve for a given confidence level connects the combinations of the photovoltaic array ratings and the corresponding minimum battery capacities capable of meeting the specified load [18]. A recent model [19] is designed an optimal autonomous hybrid PV-diesel-battery system to meet the load of an off-grid house and concluded that maximum energy is produced during the summer months when the load demand is also maximum and hence the system is most favourable as the use of the hybrid system results in saving of a lot of diesel and hence the effect of GHG is also minimised. The hybrid system with 23% of photovoltaic energy penetration and comprised of 2 kW PV array, diesel generator with a rated power of 4 kW and 2 storage batteries in addition to 2 kW converter was found to be the optimal system and it becomes economically feasible for diesel prices greater than 0.15 \$/L. The monthly average electricity production of the most feasible hybrid system showed that higher electricity production is noticed during the summer months (May-September) as compared to other months. This is a favourable characteristic, because this trend closely matches the load trend which is high during the summer months. Utilizing this system for electricity generation in comparison with the diesel only situation decreased the operational hours and consequently the diesel consumption of the diesel generators and led to reduction in emissions of GHG. Similar approaches of trade-off between loss-of-load or capacity shortage and levelised unit cost of electricity for solar home systems (SHS) have been presented for different location in India using HOMER [20]. The study suggests that different system configurations (a combination of PV module and battery capacities) can be used for different load patterns and different applications. A paper for a residential microgrid user for standalone application the photovoltaic/fuel cell/ultra-capacitor (PV/FC/UC) hybrid power system is designed and modelled [21]. To overcome the deficiency of the PV technology that its output is dependent on environmental conditions the PV system is integrated with the FC/UC system using a new topology. A detailed simulation model has been developed using Matlab/Simulink and Sim power systems packages which allows designing and analyzing any PV/FC/UC hybrid system with various power levels and parameters. The system is tested for the varying solar radiation and varying load demand, where the solar radiation and power demand data are based on real-world records. The developed system and its control strategy exhibit excellent performance for the simulation of a complete day or longer periods of time. Applications of Artificial Intelligence (AI) techniques for sizing of solar photovoltaic systems are presented [21]. AI techniques have demonstrated the possibility for sizing PV-systems successfully with reasonable accuracy. Generally, AI techniques have demonstrated the possibility for sizing PV systems based on some available data successfully and with reasonable accuracy. Literature available on the sizing of PV-systems based on AI techniques indicates their popularity, particularly in isolated areas. This shows the potential of AI as a design tool in the optimal sizing of PV systems. AI based sizing of PV systems has been

applied in many countries such as Algeria, Spain, Greece, Ireland, island and Turkey is presented [22]. Different approaches for biogas/photovoltaic hybrid power system for decentralized application for rural areas in Brazil and provide a short review about the evolution of hybrid power systems at Americas and Caribbean [23]. Genetic algorithm for designing and operational management of a PV-diesel hybrid system and an optimization of PV-diesel hybrid systems for mini-grid for an isolated island in Bangladesh is discussed [24]. In this work the electrical load is considered based on the local needs. The design of the system is based upon the fact that if the renewable energy source produces more than the one required by the loads, the excess energy can be used to charge the battery while if the amount of energy demand is higher than the one produced by the renewable energy source, the control strategy determines the most economical way to meet the energy deficit. This study reveals that the major shares of the cost are for solar panels and batteries. Technological development in solar photovoltaic technology and economic production of batteries would make rural electrification in the isolated islands more promising and demanding. The authors in [25] quantified energy losses and the most relevant performance parameters of a 2 kW, grid connected photovoltaic system in Spain. A generalized model is developed which evaluates the performance at different regions, climate conditions and irradiation. A range of (10, 15, and 30 kW) solar-diesel hybrid system micro-grids has been designed which could provide, if implemented, energy to 90% of the villages in developing countries [26]. In another study [27] it is mentioned that the amount of electricity generated could be increased by the right sizing and alignment of the arrays in a solar PV system by replacing the traditional single aperture system by interconnected arrays. A simulation model is presented to find the right size of stand-alone solar PV systems, the risk associated with failure of power supply is taken into account by a factor called loss of power supply probability (LPSP), which is the probability that the PV modules together with battery will fail to supply power on an arbitrary day. A linear programming model is also used to optimize the number of PV modules and batteries. The importance of dimensioning of a solar-wind hybrid energy system and formalised the procedure of exact determination of the energy potential and demand on site for dimensioning the system configuration is presented in [28]. It has been concluded that while designing the system for various applications and selecting the size of various components correct optimization techniques has to be used. Selecting the correct optimization technique can reduce the system cost for particular application and location.

IV. PERFORMANCE EVALUATION

A performance evaluation of solar photovoltaic system has been carried out using the available literature. Literature presents various methods for performance evaluation of SPV systems. Optimal performance of a particular SPV system depends upon the fact that how reliable are the different components that are used in that system. If the components

used in the system are easily replaceable then this could have positive impact on the system performance. System specific evaluation studies have also been highlighted and several usage related aspects. The evaluation of a nine year old solar home system and street lighting system in Indonesia is carried out and it is found that the failure rate of street lighting systems was high, although that the villagers had a positive opinion about these systems. Further, it was reported that the solar home systems performed well technically and the users were satisfied with the performance. However, in the course of time the configuration of the solar home systems had changed. Villagers had replaced the original strip lights with cheap locally made incandescent lamps and had replaced the initially installed 100 Ah capacity solar batteries with cheaper locally produced 70 Ah capacity car batteries [29]. In a similar study, the failure of bypass diodes in solar battery charging stations (SBCS) in Thailand has been analysed. The inclusion of bypass diodes in these systems created an unexpected failure mode when villagers wrongly connected their batteries with reverse polarity. In a survey of 31 stations, 18 stations were disabled by burnt-out bypass diodes [30]. The performance of a 4 kW grid connected wind/PV system with battery storage in Lowell has been reported [31]. It is reported that the power quality (total voltage distortion, frequency and voltage level) is within the acceptable limits at the point of connection to the grid i.e. connection of the system to the grid is not the point of concern. The system has a loss of power supply probability of one day in ten years. The study is based on the performance study of the practical system for two years. In this work primary resources (wind speed, irradiance) averaged over several years are helped in predicting system performance for a long period of time, the fluctuations in the resources from year to year; however, is a handicap in the determination of system component ratings that would satisfy a long-term objective like a loss of power supply probability at a minimum cost. A methodology [32] has been developed for small-scale hybridized solar PV-AC grid (HSPVACG) power system to operate with ac grid. This system consists of a photovoltaic array in-stalled on the rooftop, a hybrid power controller (HPC) and an inverter (Fig. 1). This newly developed (HPC) works in such a way that for a particular predetermined load the maximum available solar power is utilized and the remaining power is drawn from the AC grid. The load requirement and the power flow are continuously monitored. The power generated from solar panels is given preference over grid power such that the sum of the two powers equals to the required total load for the utilization of maximum solar power. This HSPVACG power system is best suited for operation during the daytime however a battery backup of two-hour duration can be incorporated for operation beyond sunshine. The system provides optimum economical use of solar PV power. This system is in fact can be substituted by the inverter battery emergency power backup (IBEPP) which is widely being used in developing countries due to unreliable grid. These IBEPP consumes a large amount of electricity addition.

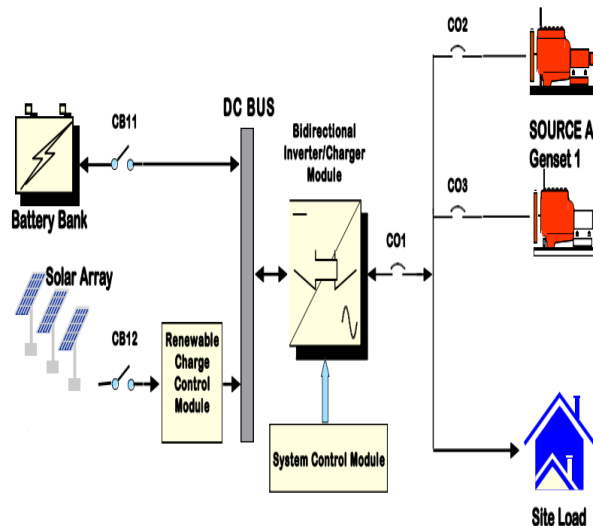

Fig. 4 Typical solar hybrid power controller (HPC) and an inverter [37]

V. POLICY AND POTENTIAL FUTURE OF TECHNOLOGICAL DEVELOPMENT PHOTOVOLTAIC

A. Policy and Legal Frameworks

Pro-active and long-term policy-oriented renewable energy programmes aimed at senior decision-makers in both Government and the private sector should be initiated. The innovative energy policy programme of the African Energy Policy Research Network (AFREPREN/FWD) provides a model example [33]. The policy programmes should be designed to demonstrate the economic and environmental benefits of renewables technologies to Africa's poor and proposes short and medium term policy initiatives that would engender large-scale dissemination of renewables. Priority should be given to highlighting the real and tangible economic benefits (such as job creation and income generation) that renewable energy programmes can deliver to the region at both the micro and macro levels. For example, renewable energy technologies are generally more labour-intensive than conventional and centralised energy projects and can help to address problems of employment of the urban and rural poor. Empirical data and information on this would possibly result in higher budgetary allocations to the development of RETs of particular interest to policy-makers in sub-Saharan Africa would be revenue neutral policy and institutional measures. For example, it is possible to make the case that the loss of revenue associated with the removal of duties and taxes on renewable energy technologies such as wind pumps can be recouped from the long-term savings in imports of petroleum fuels that require scarce convertible currencies as well as from the income and sales tax remittances from a large and functional wind pump industry.

B. Appropriate Technology, Technology Transfer and Building Local Capacity

The choice of renewable energy technologies for dissemination and development in Africa should take into

account the existing technical knowledge and local industries. Technologies that improve existing methods and build on already established industries are likely to be successfully disseminated. In addition, these technologies can become self-sustainable in the long-term. Electrical renewable energy technologies (e.g. solar PV) are unlikely to be widely disseminated in the region, due to the lack of technical know-how locally on their operation. As mentioned earlier, a significant proportion of conventional energy investments have gone to waste mainly due to the heavy emphasis on electricity and on imported technology. In addition, a significant portion of the components in electrical technologies is imported. This raises the costs and reduces the opportunities for local technological development. Mechanical, thermal, heat, technology (e.g. wind pumps, small hydro, and improved cookstoves) build on local knowledge and skills. Consequently, maintenance is a less of problem, which results in greater and more sustainable dissemination. In addition, these technologies are modular (can be increased gradually over time), and can be locally manufactured. This translates to opportunities for employment and enterprise creation locally. With increased financial support at national and international levels for such technologies, it may be possible for an African country to become a significant player in the global renewable energy industry. For instance, with the exception of solar photovoltaic technology, over 60% of the components required in many renewable energy technologies can be sourced locally. Long-term renewable energy training programmes designed to develop a critical mass of locally-trained manpower with the requisite technical, economic and social-cultural skills are urgently needed. Many of the engineering and technical courses that are currently taught at universities and colleges in Africa provide little exposure to energy technologies. Modest changes in the curricula of existing colleges and universities could significantly increase the supply of skilled renewable energy engineers, policy analysts and technicians. Both capacity and demand for local analytical-expertise-to/provide comprehensive evaluations of available renewable energy resources and options for utilising them are needed in Africa. Non-partisan groups, such as NGOs and independent research institutes and networks are well placed for performing such studies. Fostering the development of human resources and encouraging their use is a valuable area for investing donor support, as it directly equips recipient countries with tools for managing their resources on their own efforts to integrate analytical expertise within the energy sector with that of other key actors in the development process - such as expertise within the banking, social/community development and public sectors - should be included in this area of support. This is key to understanding not only the resources and technologies available but the institutional setting through which they may be adopted and the needs and interests of the target communities as well.

C. Innovative Financing Mechanisms

Priority should be given to the establishment of innovative and sustainable financing programmes for renewable energy

technologies. This may range from the creation of a National Fund for renewable energy projects financed by a modest tax on fossil fuels to credit schemes specifically aimed at developing renewable energy industries and endowment funding of renewable energy agencies. Experience has shown that most renewable energy technologies (especially those that can be locally manufactured) require subsidies only in the initial stages, and can become financially sustainable in the short to medium term after a certain level of technology dissemination has been attained. After attaining a dissemination of certain critical mass number of units and assemblers or manufacturers, the renewable energy industry can become self-sustaining and subsidies can be gradually withdrawn without any adverse effects on continued. In Ghana, a national energy fund has been successfully utilised to finance renewable energy projects and energy efficiency activities on a sustainable basis. An important challenge is the bundling of discrete renewable energy projects into large programmes, which can be financed by major bilateral and multilateral donor and financing agencies. In order to increase access to loans, banks should find alternatives to stringent requirements e.g. the collateral requirements. But since bank policy is unlikely to change in the near future, one possibility is to encourage potential consumers to form self-help groups or cooperatives so that they can acquire loans through cooperative banks, most of which do not have stringent collateral requirements. In addition, small credit-institutions-(micro-finance -institutions) could provide financing for RETs investors and users at affordable and accessible terms. Small-credit institutions are crucial in ensuring continuity when external support ceases. Many have a nationwide network in place and are able to provide service even to remote rural areas.

D. The Clean Development Mechanism/Opportunities for Africa

The Clean Development Mechanism (CDM) presents a useful financing opportunity for Africa. This mechanism allows industrialised countries to meet part of their commitment to reduce emissions by investing in projects of developing countries that reduce GHG emissions. The rationale is that emissions reduction is less costly in developing countries. The CDM could solve the financing barrier of RETs in Africa in several ways. Firstly, one of the basic requirements of the CDM is that the projects that industrialised countries invest in should meet the host country's development priorities. This provides room for the host country to select the projects for investment, and hopefully this would ensure that the host country has more leverage on the implementation of the project. The range of technologies being considered under the CDM project is wide, and includes renewable energy technologies.

VI. CONCLUSION

The following conclusions can be drawn from the thorough review of the literature available on techno-economic feasibility analysis of the SPV systems.

- 1) A generalized approach to assess suitability of SPV systems at a given location, based on techno-economic and environmental feasibility does not find good amount of coverage. However, if data based on system costs, operation and maintenance cost and other relevant cost details are made available along with the learning's from the case studies, the techno-economic feasibility assessment objective could be easily accomplished.
- 2) Conventional sizing methods such as mathematical empirical, numerical and analytical are used when all the metrological data related to a particular site is available however where these data's are not available these sizing methods could not be used and the use of artificial intelligence techniques are used in such cases.
- 3) It was found that the techno-economic assessment of SPV systems lacks the data related to economic parameters like payback period, net present value; rather they are generally based on annualized life cycle cost methods.
- 4) For a realistic estimate it is important to capture uncertainty in systems and hence stochastic modelling and simulation studies have to be encouraged in the field of energy studies.
- 5) System optimization techniques are useful for selecting ratings and types of components while designing systems for different applications.
- 6) Artificial intelligence techniques are very helpful for sizing of photovoltaic systems with some available data with sufficient accuracy and reliability particularly for isolated areas.
- 7) The cost of the PV system depends mainly on the local cost of components and hence varies from country to country and region to region and hence it is difficult to compare its life cycle cost with other types of centralised and decentralised systems for electricity generation.
- 8) In spite of the fact mentioned above techno-economic comparison of SPV systems helps in selecting proper method for electrification of un electrified in rural Africa.
- 9) Components should be selected for the SPV systems that are easily available so that replacement can be done easily and system performance is not affected because of unavailability of system components and hence the user satisfaction should be at highest level.
- 10) Solar Photovoltaic system is easy to install and SPV system has got the maximum potential in terms of electrical energy output among all the renewable energy sources.

- 11) Solar PV system can save substantial amount of diesel and also avoid excessive wear and tear of the Diesel Generator sets, therefore there is reduction in the cost of spare parts.
- 12) There are significant environmental advantages in the form of reduced emission due to lesser load on the Diesel Generator sets, whereas there is no pollution in the operation of grid interactive solar PV system.
- 13) Successful implementation of large scale SPV systems requires devising suitable policy measures after considerations of local support, institutional barriers and other social factors. This necessitates joint efforts from policy makers and modeling experts for clear representation of the energy problem and effective implementation of the solutions.

REFERENCES

- [1] T. E. Drennen, J. D. Erickson and D. Chapman, "Solar Power and Climate Change Policy in developing Countries," *Energy Policy*, Vol. 24, No. 1, 1996, pp. 9-16. doi: 10.1016/0301-4215(95)00117-4
- [2] G. C. Bakosa and M. Soursosb, "Techno-Economic Assessment of a Stand-Alone PV/hybrid Installation for Low-Cost Electrification of a Tourist Resort in Greece," *Applied Energy*, Vol. 73, No. 2, 2002, pp.183-193. doi.10.4236/sgre.2012.32020
- [3] J. L. Bernal-Agustin and R. Dufo-Lopez, "Economic and Environmental Analysis of Grid Connected Photovoltaic Systems in Spain," *Renewable Energy*, Vol. 31, No. 8, 2006, pp.1107-1128. [http://dx.doi.org/10.1016/S0306-2619\(02\)00062-4](http://dx.doi.org/10.1016/S0306-2619(02)00062-4) (Accessed 5 November, 2014).
- [4] Evaluation of Off-Grid Hybrid Photovoltaic-Diesel Battery Power Systems for Rural Electrification in Saudi Arabia—A Way Forward for Sustainable Development," *Renewable and Sustainable Energy Reviews*, Vol. 13, No. 3, 2009, pp.625-633. doi.10.4236/cweee.2013.22005
- [5] M. Kolhe, S. Kolhea and J. C. Joshi, "Economic Viability of Stand-Alone Solar Photovoltaic System in Comparison with Diesel-Powered System for India," *Energy Economics*, Vol. 24, No. 2, 2002, pp. 155-165. doi.10.4236/sgre.2012.34037
- [6] A. Stoppato, "Life Cycle Assessment of Photovoltaic Electricity Generation," *Energy*, Vol. 33, No. 2, 2008, pp.224-232. <http://dx.doi.org/10.1016/j.energy.2007.11.012>
- [7] M. Raugei and P. Frankl, "Life Cycle Impacts and Costs of Photovoltaic Systems: Current State of the Art and Future Outlooks," *Energy*, Vol. 34, No. 3, 2009, pp. 392- 399. doi:10.1016/j.reseneeco.2009.01.001
- [8] M. Kolhe, "Techno-Economic Optimum Sizing of a Stand-Alone Solar Photovoltaic System," *IEEE Transaction on Energy Conversion*, Vol. 24, No. 2, 2009, pp. 511-519. doi.10.1109/TEC.2008.2001455
- [9] M. EL-Shimy, "Viability Analysis of PV Power Plants in Egypt," *Renewable Energy*, Vol. 34, No. 10, 2009, pp.2187-2196. doi.10.4236/sgre.2012.34037
- [10] S. S. Dhrab and K. Sopin, "Electricity Generation of Hybrid PV/Wind Systems in Iraq," *Renewable Energy*, Vol. 35, No. 6, 2010, pp.1303-1307. doi.10.4236/ajac.2013.49060
- [11] N. E. Mbaka, N. J. Mucho and K. Godpromesse, "Economic Evaluation of Small-Scale Photovoltaic Hybrid Systems for Mini-Grid Applications in Far North Cameroon," *Renewable Energy*, Vol.35, No. 10, 2010, pp.2391-2398. <http://dx.doi.org/10.1016/j.renene.2010.03.005> (Accessed November 6, 2014)
- [12] S. Bogdan and M. Salameh, "Methodology for Optimally Sizing the Combination of a Battery Bank and PV Array in a Wind/PV Hybrid System," *IEEE Transactions on Energy Conversion*, Vol. 11, No. 2, 1996, pp. 367-375 doi.10.4236/sgre.2013.44043
- [13] W. D. Kellogg, M. H. Nehrir, G. Venkataramananand. V. Gerez, "Generation Unit Sizing and Cost Analysis for Stand-Alone Wind, Photovoltaic, and Hybrid-Wind/PV/System," *IEEE Transactions on Energy Conversion*, Vol. 13, No. 1, 1998, pp. 70-76 doi.10.1109/60.658206
- [14] A. N. Celik, "Techno-Economic Analysis of Autonomous PV-Wind Hybrid Energy Systems Using Different Sizing Methods," *Energy*

- Conversion and Management*, Vol. 44, No. 12, 2003, pp. 1951-1968. doi:10.4236/sgre.2012.34037
- [15] M. M. Mahmoud and I. H. Ibrik, "Field Experience on Solar Electric Power Systems and Their Potential in Palestine," *Renewable and Sustainable Energy Reviews*, Vol. 7, No. 6, 2003, pp. 531-543. doi:10.4236/sgre.2012.34037
- [16] G. Bekele and B. Palm, "Feasibility Study for a Stand-alone Solar-Wind-Based Hybrid Energy System for Application in Ethiopia," *Applied Energy*, Vol. 87, No. 2, 2010, pp. 487-495. <http://dx.doi.org/10.1016/j.apenergy.2009.06.006> (Accessed November 17, 2014)
- [17] P. Arun, R. Banerjee and S. Bandyopadhyay, "Sizing Curve for Design of Isolated Power Systems," *Energy for Sustainable Development*, Vol. 11, No. 4, 2007, pp. 21-28. doi:10.4236/sgre.2012.34037
- [18] P. Arun, R. Banerjee and S. Bandyopadhyay, "Optimum Sizing of Photovoltaic Battery Systems Incorporating Uncertainty through Design Space Approach," *Solar Energy*, Vol. 83, No. 7, 2009, pp. 1013-1025. (Accessed November 10, 2014) <http://www.scirp.org/journal/PaperInformation.aspx?PaperID=38040>
- [19] E. S. Hrayshat "Techno-Economic Analysis of Autonomous/Hybrid Photovoltaic-Diesel-Battery System," *Energy for Sustainable Development*, Vol. 13, No. 3, 2009, pp. 143-150. doi:10.4236/sgre.2012.34037
- [20] A. Chaurey and T. C. Kandpal, "A Techno-Economic Comparison of Rural Electrification Based on Solar Home Systems and PV Microgrids," *Energy Policy*, Vol. 38, No. 6, 2010, pp. 3118-3129. doi:10.1016/j.enpol.2010.01.052
- [21] M. Uzunoglu, O. C. Onar and M. S. Alam, "Modelling, Control and Simulation of a PV/FC/UC Based Hybrid Power Generation System for Stand-Alone Applications," *Renewable Energy*, Vol. 34, No. 3, 2009, pp. 509-520. doi:10.4236/sgre.2013.41013
- [22] A. Mellit, S. A. Kalogirou, L. Hontoria and S. Shaari, "Artificial Intelligence Techniques for Sizing Photovoltaic Systems: A Review," *Renewable and Sustainable Energy Reviews*, Vol. 13, No. 2, 2009, pp.406-419 <http://dx.doi.org/10.1016/j.rser.2008.01.006>(Assessed November 15, 2014)
- [23] M. R. Borges Neto, P. C. M. Carvalho, J. O. B. Carioca and J. F. Canafistula, "Biogas/Photovoltaic Hybrid Power System for Decentralized Energy Supply of Rural Areas," *Energy Policy*, Vol. 38, No. 8, 2010, pp. 4497-4506. <http://dx.doi.org/10.1016/j.enpol.2010.04.004> (Accessed November 2, 2014)
- [24] B. K. Bala and S. A. Siddique, "Optimal Design of a PV-Diesel Hybrid System for Electrification of an Isolated Island Sandwich in Bangladesh Using Genetic Algorithm," *Energy for Sustainable Development*, Vol. 13, No. 3, 2009, pp. 137-142.
- [25] M. Sidrach-de-Cardona and L. M. Lopez, "Evaluation of a Grid-Connected Photovoltaic System in Southern Spain," *Renewable Energy*, Vol. 15, No. 1-4, 1998, pp. 527-530. doi:10.1016/S0960-1481(98)00218-3
- [26] A. Schmitt, G. Huard and G. Kwiatkowski, "PV-Hybrid Microplants and Mini-Grids for Decentralised Rural Electrification in Developing Countries," EDF Research and development, France, 2006
- [27] N. Kaushika, N. K. Gautam and K. Kaushik, "Simulation Model for Sizing of Standalone Solar PV System with Interconnected Array," *Solar Energy Materials and Solar Cells*, Vol. 85, No. 4, 2005, pp.499-519. doi:10.1016/j.solmat.2004.05.024
- [28] A. Lietzmann, D. Frohler and K. Lietzmann, "Practical Experiences and Dimensioning in the Operation of Decentralized Energy Supply Stations, at RIO 5-World Climate & Energy Event," *Proceedings-of-the-International Conference*, Rio de Janeiro, 2005.
- [29] A. H. M. E. Reinders, Pramusito, A. Sudradjat, V. A. P. van Dijk, R. Mulyadi and W. C. Turkenburg, "Sukatani Revisited: On the Performance of Nine-Year-Old Solar Home Systems and Street Lighting Systems in Indonesia," *Renewable and Sustainable Energy Reviews*, Vol. 3, No. 1, 1999, pp. 1-47. doi:10.4236/sgre.2012.34037
- [30] C. Greacen and D. Green, "The Role of Bypass Diodes in the Failure of Solar Battery Charging Stations in Thailand," *Solar Energy Materials and Solar Cells*, Vol. 70, No. 2, 2001, pp. 141-149. [http://dx.doi.org/10.1016/S0927-0248\(01\)00017-4](http://dx.doi.org/10.1016/S0927-0248(01)00017-4) (Accessed November 8, 2014)
- [31] F. Giraud and Z. M. Salameh, "Steady-State Performance of a Grid-Connected Rooftop Hybrid Wind-Photovoltaic Power System with Battery Storage," *IEEE Transactions on Energy Conversion*, Vol. 16, No. 1, 2001, pp.1-7. doi:10.1109/60.911395
- [32] I. Ashraf and A. Chandra, "Techno Economic Viability of a Rooftop Hybridized Solar PV-AC Grid Assisted Power System for Peak Load Management," *2nd International Conference on Power Electronics Machines and Drives*, Vol. 1, 2004, pp. 442-446
- [33] Sampa, R. C., 1994. 'Renewable Energy Technologies Dissemination in Zambia', paper prepared for the first Regional RETs Workshop, 31 May-1 June 1994, Naivasha, Kenya, SEI-AFREPREN/FWD, Nairobi, pp. 14-15.
- [34] Makbul A. et al., (2014) <http://dx.doi.org/10.1155/2014/626251> (Accessed November 16, 2014)
- [35] Mouedj. Relal, (2014) http://ac.elscdn.com/S1876610214008340/1-s2.0-S1876610214008340main.pdf?_tid=dccb2cb8-765c-11e4-87b700000aab0f6b&acdnat=1417110374_80926b1f666a0ee3f42821c867fb9238 (Accessed November 10 2014)
- [36] Kolkata. A. (2010), http://iesonline.org/presentations/solar_july%2023_kolkata/Ashok%20Prakash.pf
- [37] Karekezi. N (2003) <http://sustainabledevelopment.un.org/content/documents/nepadkarekezi.pdf> (Accessed November 17,2014)