

Implementation of ALD in Product Development: Study of ROPS to Improve Energy Absorption Performance Using Absorption Part

Zefry Darmawan, Shigeyuki Haruyama, Ken Kaminishi

Abstract—Product development is a big issue in the industrial competition and takes a serious part in development of technology. Product development process could adapt high changes of market needs and transform into engineering concept in order to produce high-quality product. One of the latest methods in product development is Analysis-Led-Design (ALD). It utilizes digital engineering design tools with finite analysis to perform product robust analysis and valuable for product reliability assurance. Heavy machinery which operates under severe condition should maintain safety to the customer when faced with potential hazard. Cab frame should able to absorb the energy while collision. Through ALD, a series of improvement of cab frame to increase energy absorption was made and analyzed. Improvement was made by modifying shapes of frame and/or install absorption device in certain areas. Simulation result showed that install absorption device could increase absorption energy than modifying shape.

Keywords—ALD, ROPS, energy absorption, cab frame.

I. INTRODUCTION

CAB frame constructed from many types of bar and/or rod, therefore, specific characteristic of complete assembly was determined by its components. Important parameters to obtain cab's characteristic are bending and compression strength, those strengths exist in cab frame testing. Johnson [1] explained about bending rectangular anisotropic elastic beam, a mathematical solution given approach to verify that the bending stiffness is greater when twisting is prevented. Kecman [2] explained that kinematics solution was able to illustrate bending collapse of square section tube. Furthermore, to verify the solution, a series of quasi-static bending experimental of square tube with various shape were conducted. It shows that a good agreement obtained between the solution and experiment. Bending mechanism obtained hinge part which absorb energy by axially collapsing thin walled columns [3], [4]. Existing methods are then enhanced with new analytical solution that involved two unknown constants determined from minimizing a mean crumpling moment [5]. Further, characteristics of slope deflection for elastic-plastic of multi-frames are investigated by Chi et al. [6]. Assembly of frames could produce additional applied moments, therefore those moments obtained from set of linear

algebraic solution which verified by numerical analysis.

Beside square or rectangular shape, cab frame also has cylindrical type. Thin-walled cylindrical tubes for axial impact were investigated by Adachi et al. [7]. Crushing impact test for several cylinders with ribs showed improved energy absorption characteristic. Specific axial crushing of multi compact-impact member to substitute conventional thin-walled cylindrical tube improved load efficiency characteristic. A similar study also conducted for cylindrical tube for axial crushing test called compress-expand member tube. Collapse modes of those members showed stable deformation than single cylindrical tube, therefore energy absorption also increases due to wider range of absorption area [8], [9].

The comprehensive analysis of vehicle safety device to protect rolling accident was following safety standard procedure ISO 3471 [10]. Roll over protecting structure called ROPS was standard device for protecting operator when collision happens. Various types of ROPS were tested according to SAE 2009 [11]. Real collision test was the most reliable method to verify ROPS, but it requires huge effort to conduct [12]. There was difficult to predict mathematical solution precisely on crushing load when roll over, due complexity of ROPS assembly and nonlinear characteristic of material [13]. Finite element analysis was ideal to obtain deformation load and perform up-front engineering approach. This method is fully integrated in ALD phase [14]. Design of two-post ROPS using finite element analysis showed that buckling could happen due to non-uniform distribution of bending load which concentrated at specific area [15].

This research aims to optimize energy absorption performance of cab frame using series of improvement combinations. Those improvements were arranged using design experiment of Taguchi's method. Series of improvement was adopted from previous researches. It consists of modification of frame and install new absorption device placed inside cab frame. Result of improvement compared each other to find the highest energy absorption. Finite element method was performed using MSC Marc software to produce simulation and numerical analysis.

II. METHODOLOGY

Cab frame model was constructed as general shape, used rectangular bars with six-post vertical ROPS. Meanwhile, basic shape of frame, which composes full cab frame, was rectangular ($C_1=C_2$). Finite element model represents quadrilateral element type. Material properties are considered

Zefry Darmawan is Student at graduate School of Science and Engineering, Yamaguchi University, Ube, Japan (e-mail: v501wc@yamaguchi-u.ac.jp).

Shigeyuki Haruyama and Ken Kaminishi are Professor graduate School of Innovation and Technology Management, Yamaguchi University, Ube, Japan (e-mail: haruyama@yamaguchi-u.ac.jp, kaminishi@yamaguchi-u.ac.jp).

as homogen isotropic elastic-plastic. Work hardening of plasticity material follows bilinear isotropic hardening in uniaxial stress. Rolling test considered as static circumstance according to the Organization for European Economic Co-operation (OECC) [16]. Stress-strain relationship is assumed according to rules (1):

$$\begin{aligned} \sigma &= E\varepsilon \quad [\varepsilon < \sigma_y/E] \\ \sigma &= \sigma_y + E_h(\varepsilon - \sigma_y/E), \quad [\varepsilon > \sigma_y/E] \end{aligned} \quad (1)$$

Detail of material properties are listed in Table I.

TABLE I
MATERIAL PROPERTIES

Modulus Young [E]	205,9 [GPa]
Poisson ratio [ν]	0,3
Yield stress [σ _y]	E/1000 [MPa]
Hardening ratio [E _h /E]	1/100

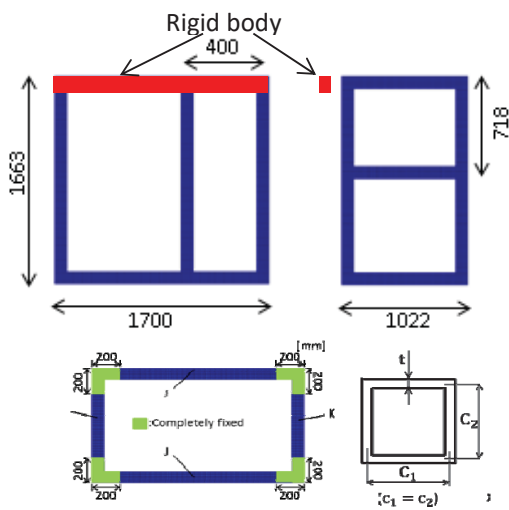

Fig. 1 Geometry of cab frame

TABLE II
TAGUCHI'S ORTHOGONAL ARRAY

	A	B	C	D	E	F	G	H	I	J	K
L12-1	1	1	1	1	1	1	1	1	1	1	1
L12-2	1	1	1	1	1	2	2	2	2	2	2
L12-3	1	1	2	2	2	1	1	1	2	2	2
L12-4	1	2	1	2	2	1	2	2	1	1	2
L12-5	1	2	2	1	2	2	1	2	1	2	1
L12-6	1	2	2	2	1	2	2	1	2	1	1
L12-7	2	1	2	2	1	1	2	2	1	2	1
L12-8	2	1	2	1	2	2	2	1	1	1	2
L12-9	2	1	1	2	2	2	1	2	2	1	1
L12-10	2	2	2	1	1	1	1	2	2	1	2
L12-11	2	2	1	2	1	2	1	1	1	2	2
L12-12	2	2	1	1	2	1	2	1	2	2	1

This research is using combination of thickness levels based on Taguchi's method. Thickness level 1 is 2 mm and level 2 is 4 mm, assembly of frame named (A-K) is the total of factors. There are 12 finite element simulations conduct in MSC Marc. Improvement of frame conducted according to previous

research:

- Improving bending capacity of rectangular tubes by varying (C_2/C_1) and thickness (t) Masuda et al. [17].

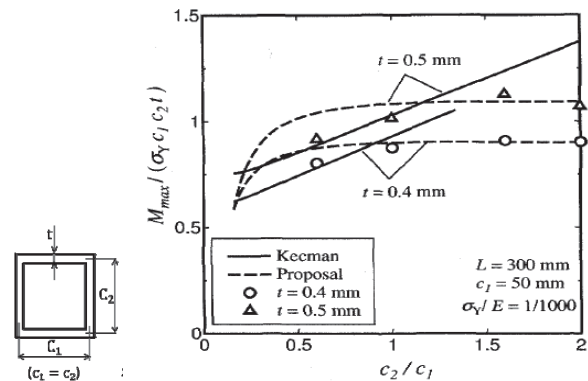

Fig. 2 Comparison between Kecman's theory and FE analysis. Cited from Masuda et al. [17]

TABLE III
PARAMETER FOR BENDING IMPROVEMENT

C_2/C_1	C_2 [mm]	C_1 [mm]
1,5	150	100
1,7	170	100
2	200	100

- Improving axial compress capacity by choosing appropriate thickness to length (b/t) Shinohara et al. [18].

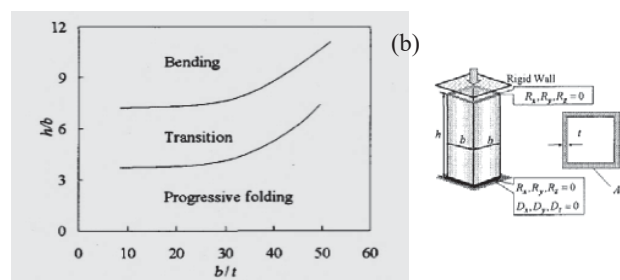
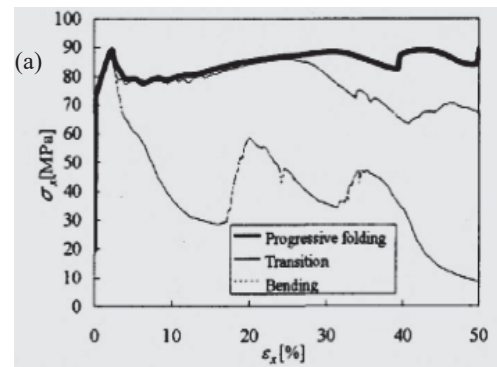

Fig. 3 (a) Stress-strain curve of deformation mode, and (b) Deformation mode mapping, cited from Shinohara et al. [18]

- Reduce buckling by install energy absorption part at certain area Haruyama et al. [19].

TABLE IV
PARAMETER FOR AXIAL COMPRESS IMPROVEMENT

h/b	h [mm]	b [mm]	b/t	t [mm]
5,48	822	150	42,8	3,5
5,48	822	150	50	3
5,48	822	150	75	2

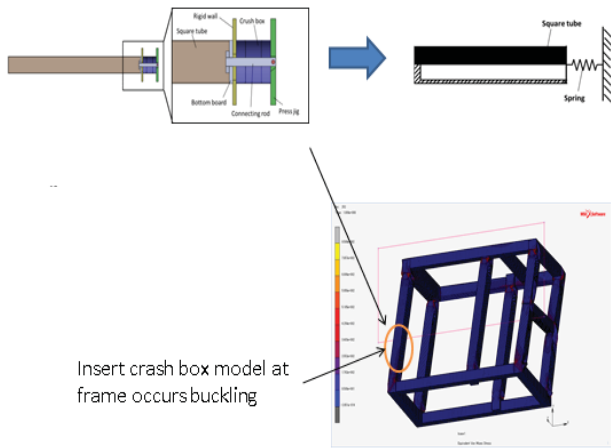

Fig. 4 Install absorption part at cab frame

III. RESULTS

A. Improve Absorption Energy by Thickness Condition

Finite analysis performed using MSC Marc to produce side collision of cab frame. A rigid wall created as ground surface similar when rolling happen and produce force to cab frame structure. Therefore, the dimension of the rigid wall is (1700mm x 100mm), and total penetration of rigid wall to cab frame is 500mm. Initial ROPS analysis according to Taguchi's method at Table II resulted various absorption energy.

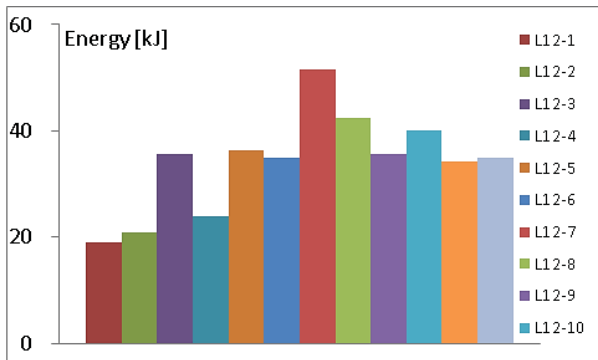

Fig. 5 Comparison energy of cab frame

From Fig. 5, it resulted that L12-7 is the highest energy and L12-1 is the lowest. In that case, thickness condition influences energy absorption. Simulation L12-7 was selected as basic comparison for improvement to verify better result.

B. Improve Bending and Compress Capacity

Based on Tables III and IV, improvement created simulation to improve bending and compress capacity. Detail of simulation followed Tables V and VI.

TABLE V
IMPROVEMENT OF BENDING AND COMPRESS

A,B,C Bending	Level 1	$C_2=15\text{mm}$
	Level 2	$C_2=17\text{mm}$
	Level 3	$C_2=20\text{mm}$
E Compress	Level 1	$t=2\text{mm}; b=150\text{mm}$
	Level 2	$t=3\text{mm}; b=150\text{mm}$
	Level 3	$t=3,5\text{mm}; b=150\text{mm}$

TABLE VI
ORTHOGONAL ARRAY OF IMPROVEMENT BENDING-COMPRESS

Rep/frame	A	B	C	E
L91	1	1	1	1
L92	1	2	2	2
L93	1	3	3	3
L94	2	1	2	3
L95	2	2	3	1
L96	2	3	1	2
L97	3	1	3	2
L98	3	2	1	3
L99	3	3	2	1

Result of improvement on bending and compress capacity then compared with simulation L12-7. This L12-7 then will be called as default.

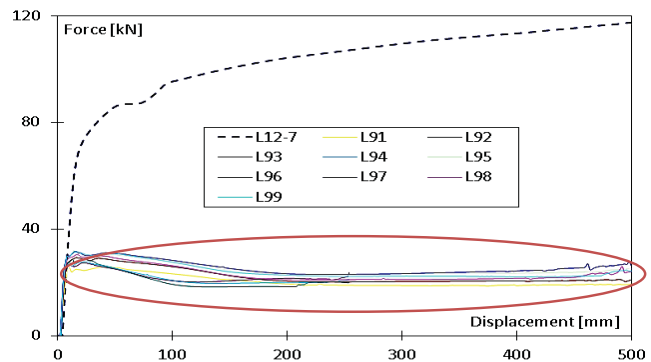

Fig. 6 Force result of improvement bending-compress

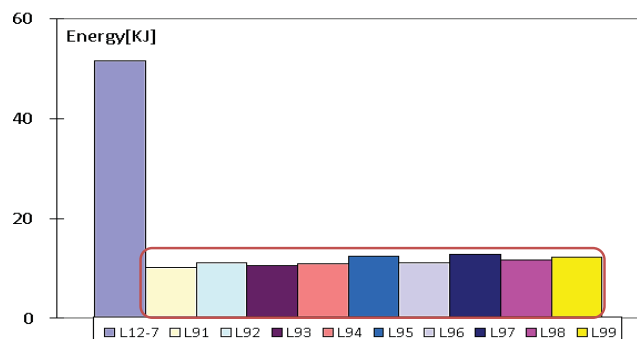

Fig. 7 Comparison of energy absorption between (L12-7) and improvement bending-compress

C. Improve Energy by Install Energy Absorption Part

In this step improvement divided into several categories. Absorption part will be placed at certain area of cab frame where obtained buckling. Based on improvement in Section III

A, buckling occurs at several areas. Absorption part next called as crash box.

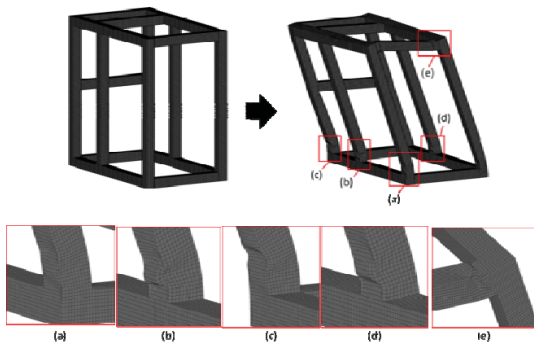

Fig. 8 Buckling area

According to Fig. 8, absorption part will be placed at 4 improvement locations. Those locations were; lower bottom of frame C; lower side of frames A, B, C; upside of frames A, B, C; and at frame E. Results of install crash box at cab frame are shown in Figs. 10 and 11.

IV. DISCUSSION

Improvement in Section III B showed that result on bending-compress improvement worse than the improvement explained in Section III A. According to study of [16], [17] improvement result should show better than default. However, previous study was conducted for single material, the theory was not applicable when adopted for cab frame which consist of many part.

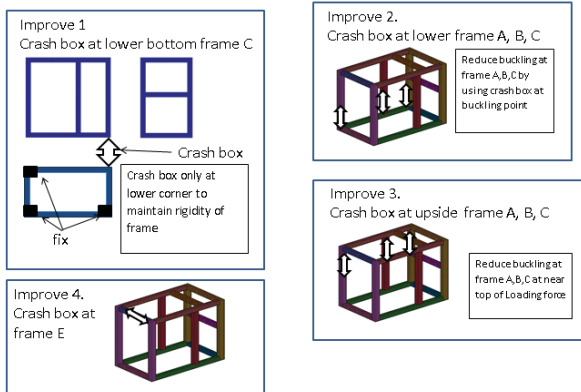

Fig. 9 Location of crash box

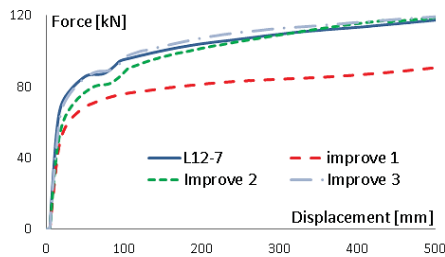

Fig. 10 Result of force on install crash box

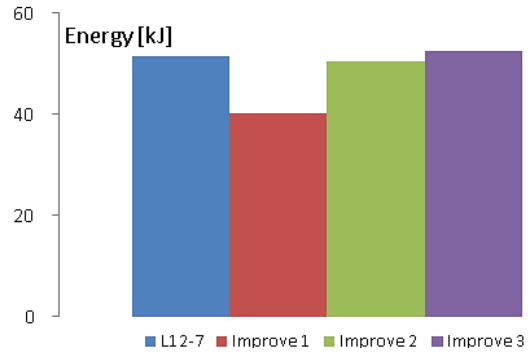

Fig. 11 Result of energy on install crash box

Those condition also obtain in Section III C, result of install crash box showed a little increase about 1,97% than default. This increasing obtained from improvement 3, when install crash box at upside of frames A, B, C. The result was not quite significant and possible to failure due to limitation of crash box design. According to SAE J1040[20] deformation on cab frame should not exceed deflection limiting volume (DLV) 15°.

Design of crash box for single rectangular tube showed that it could improve moment bending and reduce buckling. However, at that study there was no bending angle limitation as in DLV of cab frame. Due to the limitation crash box design was not compatible if install at cab frame for absorb roll over energy. Crash box only absorb energy at 13mm of stroke length, while it needs more stroke to produce higher absorption.

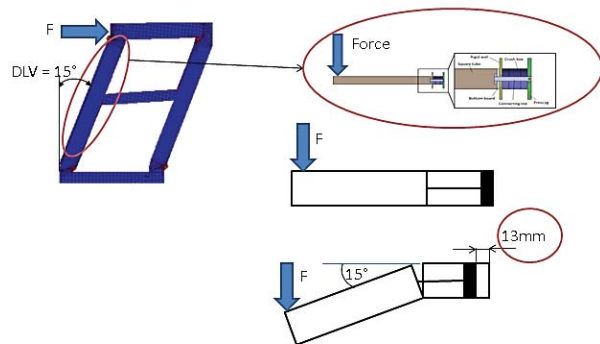

Fig. 12 Limitation of bending crash box at DLV of cab frame

Due to the problem exist on bending crash box, the new design of absorption part was developed. New design should enable to absorb energy at such limiting DLV. Basic principal is using tensile stress at rear diagonal side of cab frame. The diagonal side provide enough strokes to absorb deflection energy at cab frame, based on cab's model dimension stroke length was 214mm.

Mechanism of tensile crash box at rear diagonal side of cab frame followed simple tensile at diagonal wire. When cab deflected this wire could tighten between two-post. The elongation of wire used to squeeze the axial compress part. The compress part properties adopted from bending crash box

from the improvement explained in Section III C.

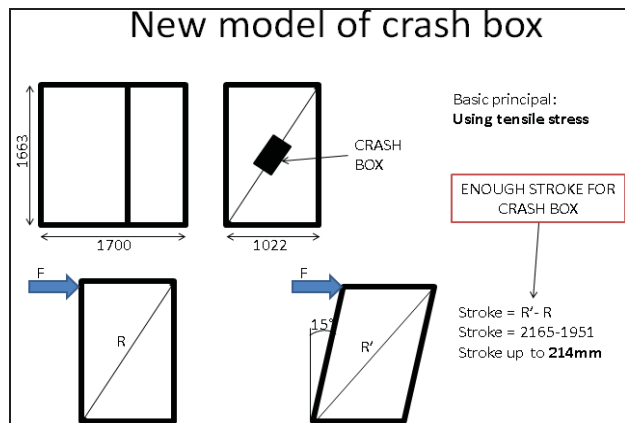

Fig. 13 New design of crash box

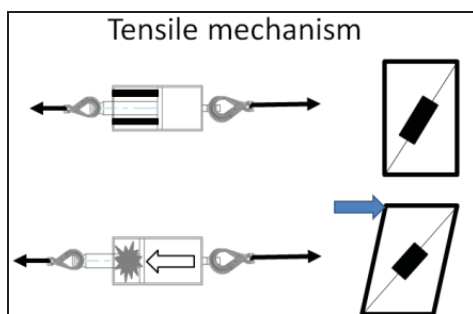

Fig. 14 Tensile crash box mechanism

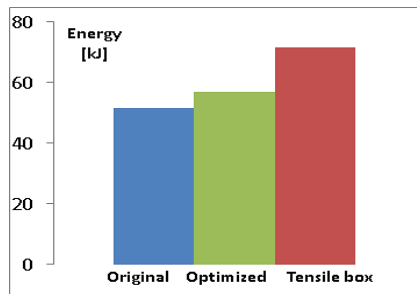

Fig. 15 Comparison absorption energy between default, optimized, and tensile box model

V. CONCLUSION

A series of improvement were made to investigate energy absorption of cab frame. The result shown that:

1. ROPS using tensile box improve energy absorption up to 25,83% compare than optimized ROPS (L12-7 optimized). While comparing with original ROPS (L12-7) increased significantly 38,97%.
2. Tensile crash box has possibilities increased energy absorption of ROPS

REFERENCES

[1] Johnson, A, F. 1973. Bending and torsion of anisotropic beams. International Journal of Solids Structure, vol. 9, pp. 527-551.

- [2] Kecman, D. 1983. Bending collapse of rectangular and square section tubes. International Journal of Mechanical Sciences, vol. 25, pp. 623-636.
- [3] Wierzbicki, T., Recke, L., Abramowicz, W., & Gholami, T. 1994. Stress profiles in thin-walled prismatic column subjected to crush loading-I, Compression. Journal of Computers and Structures, vol. 51, pp. 611-623.
- [4] Wierzbicki, T., Recke, L., Abramowicz, W., Gholami, T., & Huang, J. 1994. Stress profiles in thin-walled prismatic column subjected to crush loading-II, Bending. Journal of Computers and Structures, vol. 51, pp. 625-641.
- [5] Kim, T, H., & Reid, S, R. 2001. Bending collapse of thin-walled rectangular section columns. Journal of Computers and Structures, vol. 79, pp. 1897-1911.
- [6] Chi, K, S., & Lin, T, H. 1977. Slope-deflection method for elastic-plastic multistory frames. International Journal of Solids Structure, vol. 13, pp. 125-135.
- [7] Adachi, T., Tomiyama, A., Araki, W., Yamaji, A. 2008. Energy absorption of a thin-walled cylinder with ribs subjected to axial impact. International Journal of Impact Engineering, Vol. 35, no. 2, p. 65-79.
- [8] Haruyama, S., Muhamad, A, K., kaminishi, K., & Chen, D, H. 2013. Modes of collapse of compress-expand member under axial loading. Journal of World Academy of Science, engineering and Technology, vol. 7, pp. 550-557.
- [9] Haruyama, S., Tanaka, H., Chen, D, H. & Muhamad, A, K. 2012. Study on the deformation modes of an axially crushed compact impact absorption member. Journal of World Academy of Science, engineering and Technology, vol. 6, pp. 1105-1113.
- [10] ISO3471. 2008. Earth-moving machinery roll-over protective structures laboratory tests and performance requirements. International Organization for Standardization, Geneva.
- [11] SAE. 2009. Roll-Over Protection Structures (ROPS) for wheeled agricultural tractors. SAEJ2194. SAE International.
- [12] Chen, C., Wang, G., Zhang, Y., & Si, J. 2012. Effect of lateral stiffness coefficient of loader ROPS on human injury in a lateral rollover incident. Journal of Biosystems Engineering, Vol. 113, no. 2, pp. 207-219.
- [13] Kim, T, H., & Reid, S, R. 2001. Multiaxial softening hinge model for tubular vehicle roll-over protective structures. International Journal of Mechanical Sciences, vol. 43, pp. 2147-2170.
- [14] Haruyama, S., Muhamad, A, K., Kyoutani, T., Chen, D, H., & Kaminishi, K. 2013. Implementing ALD in product development: The effect of geometrical dimensions on tubular member deformation. Journal of World Academy of Science, engineering and Technology, vol. 7, pp. 1114-1118.
- [15] Khorsandi, F., Ayers, P, D., & Truster, T, J. 2017. Developing and evaluating a finite element model for predicting the two-post rollover protective structure nonlinear behavior using SAE J2194 static test. Biosystem engineering, Vol. 156, pp. 96-107.
- [16] OEEC. 1959. OEEC Standard code for the official testing of agricultural and forestry tractors. Paris, France: Organization for the European Economic Co-operation.
- [17] Masuda, K., Chen, D, H., & Ozaki, S. 2009. Study on pure bending collapse of square tubes in consideration of work-hardening effect (Japanese version). The Japan Society of Mechanical Engineers, vol. 75, pp. 13-20.
- [18] Shinohara, M., Chen, D, H., & Ozaki, S. 2009. Numerical study of axial crushing characteristic for square tube (Japanese version). The Japan Society of Mechanical Engineers, vol. 6-4, pp. 191-192.
- [19] Haruyama, S., Darmawan, Z., & Kaminishi, K. 2017. Study on bending characteristic of square tube using energy absorption part. Journal of World Academy of Science, engineering and Technology, vol. 11-4, pp. 885-891.
- [20] SAE J1040. 1994. Performance criteria for Rollover Protective Structures (ROPS) for construction, Earthmoving, Forestry, and Mining machines. Washington. The Executive Director Office of The Federal Register the United States of America.