

Impact of GCSC on Measured Impedance by Distance Relay in the Presence of Single Phase to Earth Fault

M. Zellagui, A. Chaghi

Abstract—This paper presents the impact study of GTO Controlled Series Capacitor (GCSC) parameters on measured impedance (Z_{seen}) by MHO distance relays for single transmission line high voltage 220 kV in the presence of single phase to earth fault with fault resistance (R_F). The study deals with a 220 kV single electrical transmission line of Eastern Algerian transmission networks at Group Sonelgaz (Algerian Company of Electrical and Gas) compensated by series Flexible AC Transmission System (FACTS) i.e. GCSC connected at midpoint of the transmission line. The transmitted active and reactive powers are controlled by three GCSC's. The effects of maximum reactive power injected as well as injected maximum voltage by GCSC on distance relays measured impedance is treated. The simulations results investigate the effects of GCSC injected parameters: variable reactance (X_{GCSC}), variable voltage (V_{GCSC}) and reactive power injected (Q_{GCSC}) on measured resistance and reactance in the presence of earth fault with resistance fault varied between 5 to 50 Ω for three cases study.

Keywords—GCSC Parameters, Transmission line, Earth fault, Symmetrical components, Distance protection, Measured impedance.

I. INTRODUCTION

FAULT currents have an important influence on the design and operation of equipment and power systems. In Algerian Company of Electrical and Gas, more than 83% of the occurred faults on 220 and 400 kV overhead transmission networks are single phase to ground type. However, phase to phase faults are the most common fault type after single phase to ground faults. Distance protection relays have been widely applied as the primary protection in high voltage transmission lines due to their simple operating principle and capability to work independently under most circumstances [1-2].

The basic operation principle of distance relay is based on the fact that the line impedance is fairly constant with respect to the line length. However, the implementation of FACTS Controllers in power system transmission for enhancing the power system controllability and stability have introduced new power system issues in the field of power system protection that must be considered and analyzed [3]. Some of the concerns include the rapid changes in line impedance and the transients introduced by the fault occurrence with the associated control action of the FACTS Controllers. The presence of the FACTS devices in the faulted loop introduces changes to the line parameters seen by the distance relay.

M. Zellagui is with LSP-IE Research Laboratory, Department of Electrical Engineering, University of Batna, Campus CUB, 05000 Algeria (phone: 213-555-529-402; fax: 213-33-815-123; e-mail: m.zellagui@ymail.com).

A. Chaghi is with LSP-IE Research Laboratory, Department of Electrical Engineering, University of Batna, Campus CUB, 05000 Algeria (phone: 213-556-557-102; fax: 213-33-815-123 (e-mail: az_chaghi@univ-batna.dz).

The effect of FACTS device would affect both the steady state and transient trajectory of the apparent impedance seen by distance relays due to the fast response time of FACTS Controllers with respect to that of the protective devices. The impact of FACTS devices on distance protection varies depending on the type of FACTS device used, the application for which it is applied and the location of the FACTS device in the power system.

The effect of different types of series FACTS devices on distance protection of transmission lines has been reported: for Thyristor Controlled Series Capacitor (TCSC) in [4-7] and for Static Synchronous Series Compensator (SSSC) in [8-9], for shunt FACTS devices the type Static Synchronous Compensators (STATCOM) is study in [10-12] and for Static Var Compensators (SVC) in [13-14]. However, the authors have not come across any reported work on mitigation of the impact of midpoint series FACTS compensated transmission lines on distance protection.

In this paper we report the impact of variation of maximum reactive power injected by GCSC for three case study in the presence phase to earth faults (phase A) at the end of the transmission line with resistance fault (R_F). The GCSC is located on 220 kV midline of the Algerian transmission line between substations Ain M'lila and Khenchela which is protected by MHO distance relay installed at busbar A. The study concerns the impact of injected parameters (X_{GCSC} , V_{GCSC} and Q_{GCSC}) of the GCSC on the measured impedance of by distance relay R_{seen} and X_{seen} for protected transmission line in presence of resistance fault which varies between 5 to 50 Ω .

II. REACTIVE POWER ON TRANSMISSION LINE IN PRESENCE GCSC

The compensator GCSC mounted on figure 1.a is the first that appears in the family of series compensators. It consists of a capacitance (C) connected in series with the electrical transmission line and controlled by a valve-type GTO thyristors mounted in anti-parallel and controlled by an extinction angle (γ) varied between 0° and 180° [15-17] controlled series compensation, apply dynamic control of the degree of series compensation in a long transmission line.

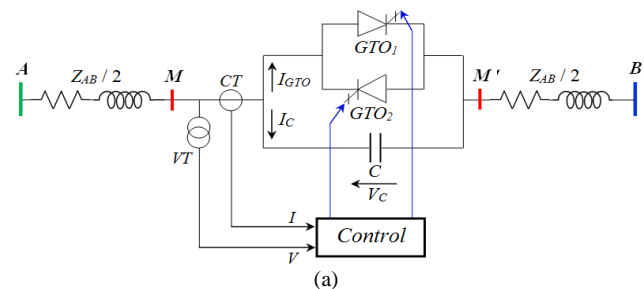

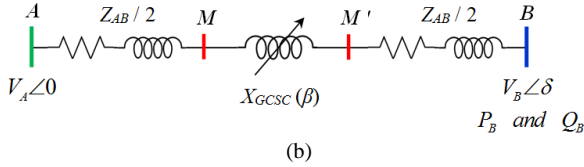

Fig. 1 Transmission line in presence of GCSC system a) Control principle, b) Apparent reactance

Figure 2 shows typical current and voltage waveforms for the GCSC of Figure 1, for a given blocking angle γ [16]. It is assumed that the transmission line current (I_L), is sinusoidal.

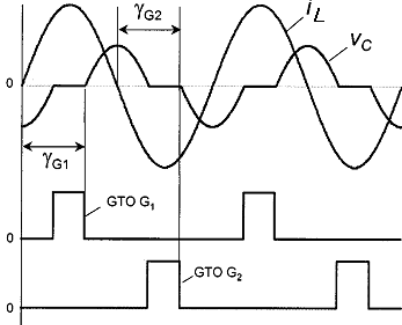

Fig. 2 GCSC current, voltage waveforms, and switch control

This compensator injected in the transmission line AB between busbar A (source) and B (load) a variable capacitive reactance (X_{GCSC}). From figure 1.b this capacitive reactance is defined by the following equation [18-19]:

$$X_{GCSC}(\gamma) = X_{C,Max} \left[1 - \frac{2}{\pi} \gamma - \frac{1}{\pi} \sin(2\pi\gamma) \right] \quad (1)$$

Where,

$$X_{C,Max} = \frac{1}{C_{GCSC} \cdot \omega} \quad (2)$$

The conduction angle (β) which varies between 0 to 90° is defined by next relation:

$$\beta = \pi - 2\gamma = 2 \left(\frac{\pi}{2} - \gamma \right) \quad (3)$$

From equation (3), the equation (2) becomes:

$$X_{GCSC}(\beta) = X_{C,Max} \left[1 - \left(\frac{\pi - \beta}{\pi} \right) - \frac{1}{\pi} \sin(\pi(\pi - \beta)) \right] \quad (4)$$

Where, the relation of injected voltage is:

$$V_{GCSC}(\beta) = V_{GCSC-Max} \left[1 - \left(\frac{\pi - \beta}{\pi} \right) - \frac{1}{\pi} \sin(\pi(\pi - \beta)) \right] \quad (5)$$

The reactive injected power by GCSC is:

$$Q_{GCSC}(\beta) = \frac{V_{GCSC}(\beta)^2}{X_{GCSC}(\beta)} \quad (6)$$

The active and reactive power at busbar B with GCSC is defined by following equations:

$$P_B(\delta) = \frac{V_A \cdot V_B}{R_{AB} - X_{GCSC}} \sin(\delta) \quad (7)$$

$$Q_B(\delta) = P_B(\delta) = \frac{V_B^2}{Z_{AB} - X_{GCSC}} - \frac{V_A \cdot V_B}{Z_{AB} - X_{GCSC}} \cos(\delta) \quad (8)$$

Where,

$$\begin{cases} V_B = V_{B,W} + V_{GCSC} \\ V_{B,W} = V_{A,W} - \Delta V \end{cases} \quad (9)$$

The $V_{A,W}$ and $V_{B,W}$ represent voltages at busbar A and B respectively without GCSC.

III. IMPEDANCE MEASURED BY MHO DISTANCE RELAY

Distance protection has been widely used in the protection of EHV and HV transmission lines. The basic principle of MHO distance protection involves the division of the voltage at the relaying point by the measured current [1], [29]. The apparent impedance so calculated is compared with the reach point impedance. If the measured impedance (Z_{seen}) is less than the reach point impedance, it is assumed that a fault exists on the line between the relay and the reach point.

The basic principle of operation of distance protection is shown in figure 3. The input to the relay point is the phase voltages and line currents transformed with the help of voltage transformer (VT) and current transformers (CT).

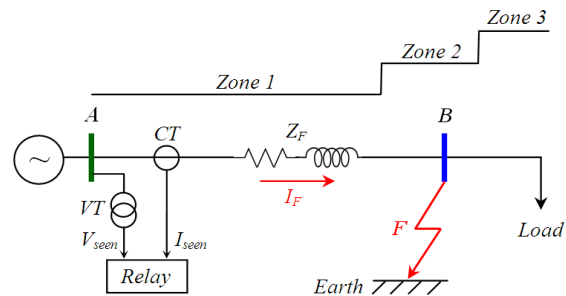

Fig. 3 Principle of MHO distance protection in presence phase to earth fault with R_f .

The voltage would fall towards zero at the point of the fault. The impedance measured by MHO distance relay (Z_{seen}) in presence phase (A) to earth fault is calculate by flowing equation [20-21]:

$$Z_{seen} = \frac{V_{Relay}}{I_{Relay}} = \frac{V_A / I_A + K_o \cdot I_o}{K_Z} = R_{seen} + j \cdot X_{seen} \quad (10)$$

$$\text{Where, } K_o = \frac{Z_o - Z_1}{3Z_1} \quad \text{and} \quad K_z = \frac{K_{CT}}{K_{VT}} \quad (11)$$

IV. SINGLE PHASE TO EARTH FAULT CURRENT CALCULATION ON PRESENCE GCSC

Figure 4 is shows the equivalent circuit for transmission line en presence single phase (A) to ground fault with fault resistance (R_F) at busbar B with GCSC inserted on midline.

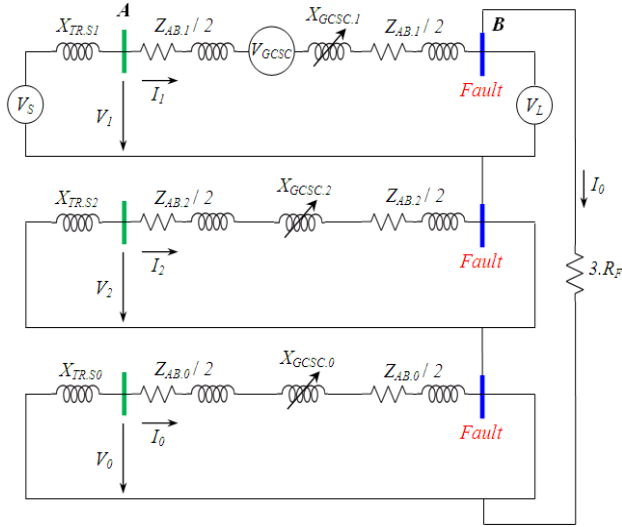

Fig. 4 The equivalent circuit with GCSC

The total transmission line ($Z_{AB-GCSC}$) impedance with GCSC inserted on midline is given by:

$$Z_{AB-GCSC} = R_{AB} + j[X_{AB} - X_{GCSC}(\beta)] \quad (12)$$

Regarding reference [22-23], the basic equation for this fault is:

$$I_b = I_c = 0 \quad (13)$$

$$V_a = V_1 + V_2 + V_0 = R_F \cdot I_a \neq 0 \quad (14)$$

The coefficients Z_{AB-T} and Z_{GCSC-T} are defined for simplicity is:

$$Z_{AB-T} = Z_{AB,1} + Z_{AB,2} + Z_{AB,0} \quad (15)$$

$$X_{GCSC-T} = X_{GCSC,1} + X_{GCSC,2} + X_{GCSC,0} \quad (16)$$

From figure 4, the symmetrical currents components are:

$$I_1 = I_2 = I_0 = \frac{V_s + V_{GCSC}}{\left(\frac{Z_{AB-T}}{2}\right) + X_{GCSC-T} + \left(\frac{Z_{AB-T}}{2}\right) + 3.R_F} \quad (17)$$

$$\text{Where, } I_1 + I_2 + I_0 = \frac{I_A}{3} \quad (18)$$

From equations (17) and (18), the current in phase A is:

$$I_A = \frac{3.(V_s + V_{GCSC})}{\left(\frac{Z_{AB-T}}{2}\right) + X_{GCSC-T} + \left(\frac{Z_{AB-T}}{2}\right) + 3.R_F} \quad (19)$$

The symmetrical components of voltages are:

$$\begin{bmatrix} V_0 \\ V_1 \\ V_2 \end{bmatrix} = \frac{1}{3} \begin{bmatrix} 1 & 1 & 1 \\ 1 & a & a^2 \\ 1 & a^2 & a \end{bmatrix} \begin{bmatrix} V_A \\ V_B \\ V_C \end{bmatrix} \quad (20)$$

From equation (14) and matrix (20), the voltage at phase A is:

$$V_A = \frac{3.R_F.(V_s + V_{GCSC})}{\left(\frac{Z_{AB-T}}{2}\right) + X_{GCSC-T} + \left(\frac{Z_{AB-T}}{2}\right) + 3.R_F} \quad (21)$$

From equations (10), (17), (19) and (21), the measured impedance Z_{seen} by distance relay is only related to:

- Parameters of transmission line : U_n , I_L , R_{AB} , and X_{AB} ,
- Current and voltage transformer ratios: K_{CT} and K_{VT} ,
- Parameters of GCSC installed: V_{GCSC} and X_{GCSC} ,
- Fault conditions: location n_F and resistance R_F .

V. CASE STUDY AND SIMULATION RESULTS

The electrical network 220 kV studied in this paper is the eastern Algerian electrical transmission networks at Algerian company of Electrical and Gas is shows [24] in figure 5.

The MHO distance relay is located on the busbar at Ain M'liila in Oum El Bouaghi to protect the single transmission line between busbar A and busbar B at Khenchela substation 220/60kV in Algeria. The GCSC system is installed in the midpoint of the protected transmission line by a MHO distance relay.

The investigation were carried out for three case studies respectively for 30, 50 and 70 MVar of injected reactive power as well as for 10, 20 and 30 kV injected voltage. The parameters of transmission line and the installed GCSC are summarized in the appendix.

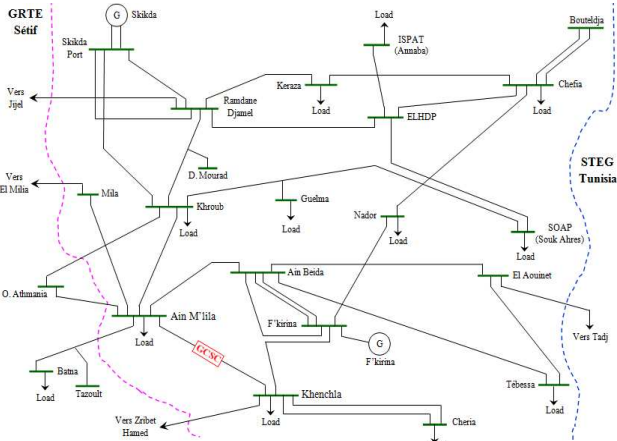

Fig. 5 220 kV Algerian electrical networks study

A. Impact GCSC on transmission line protected

The figures 6.a and 6.b represent the variation of reactive power (Q_B) and active power (P_B) at the load busbar B respectively as a function of injected X_{GCSC} by different GCSC.

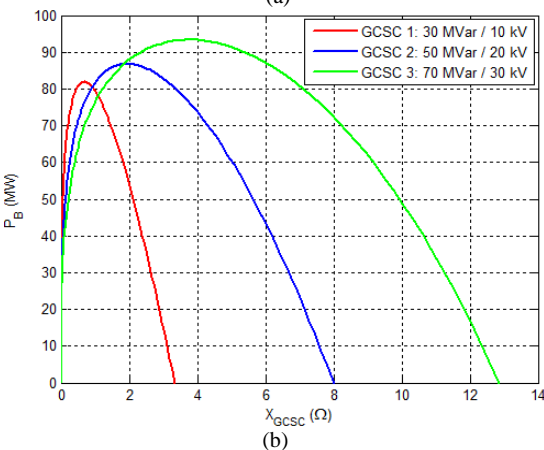
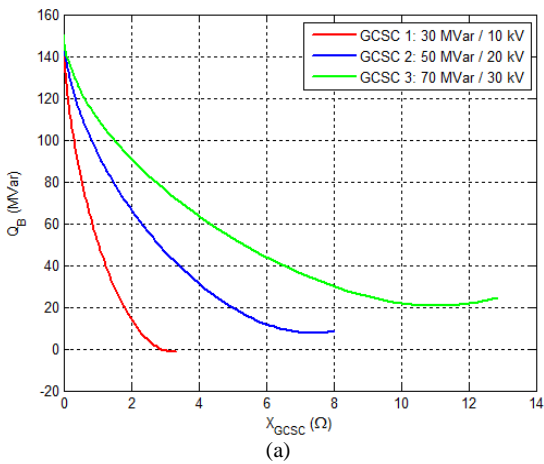

Fig. 6 Powers Variation with respect to injected reactance.
a). $Q_B = f(X_{GCSC})$, b). $P_B = f(X_{GCSC})$

B. Impact of X_{GCSC} on the impedance measured by relay

The figures 7.a and 7.b represent the variation of the resistance R_{seen} and reactance X_{seen} respectively as a function of injected X_{GCSC} by different GCSC in the presence R_F .

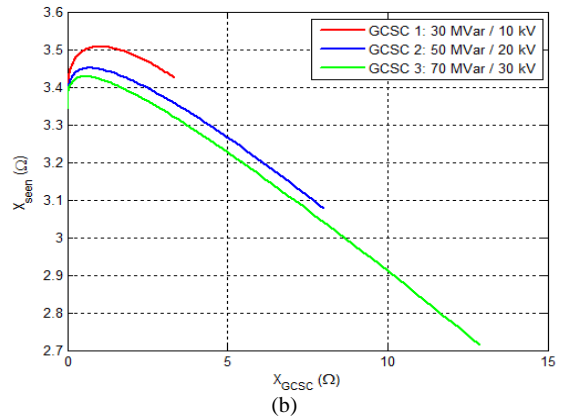
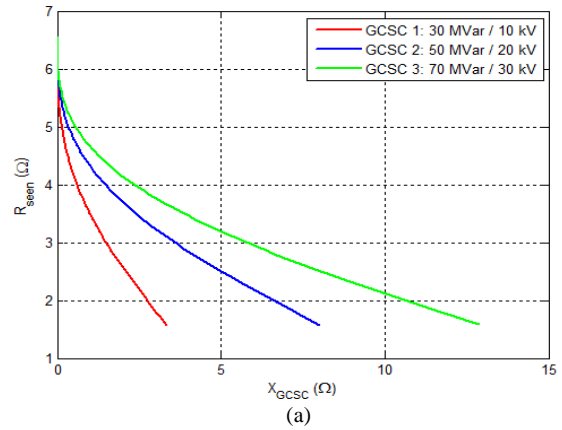
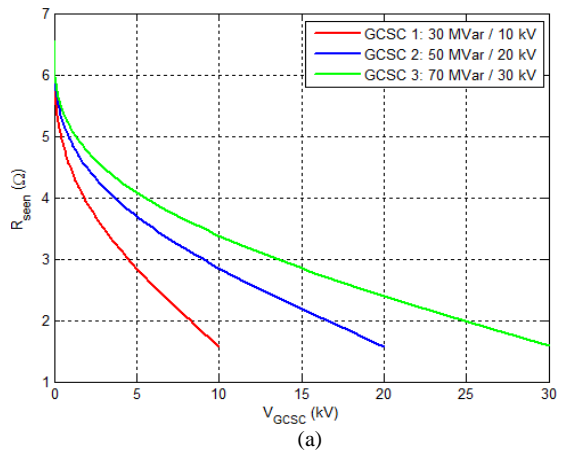

Fig. 7 Distance relay measured impedance variation Z_{seen}
a). $R_{seen} = f(X_{GCSC})$, b). $X_{seen} = f(X_{GCSC})$

C. Impact of V_{GCSC} on impedance measured by relay

Figures 8.a and 8.b represent the variation of R_{seen} and X_{seen} respectively as a function R_F for different injected voltage V_{GCSC} by different GCSC study.



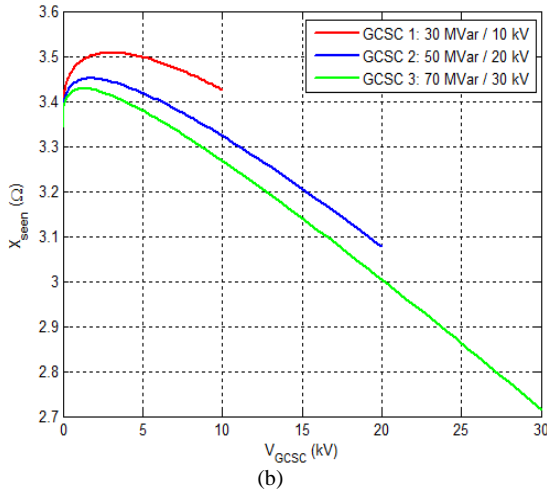

Fig. 8 Distance relay measured impedance variation Z_{seen}
a). $R_{seen} = f(V_{GCSC})$, b). $X_{seen} = f(V_{GCSC})$

D. Impact of Q_{GCSC} on impedance measured by relay

Figures 9.a and 9.b represent the variation of R_{seen} and X_{seen} as a function R_F for different injected Q_{GCSC} injected by different GCSC study.

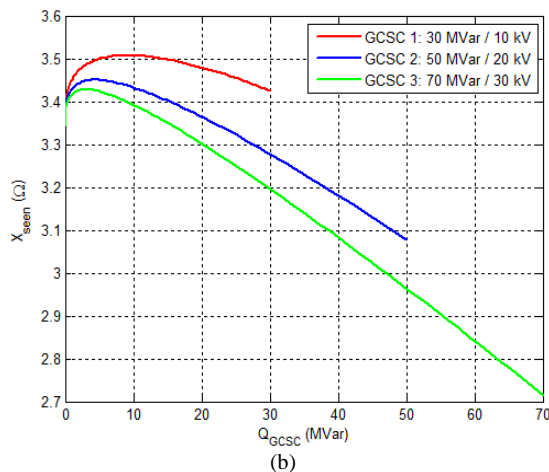
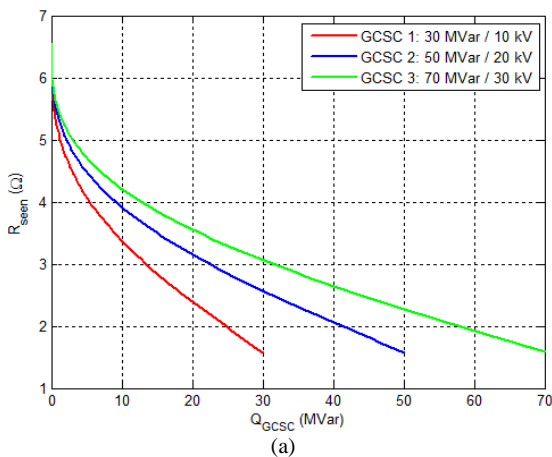

Fig. 9 Variation of impedance Z_{seen} by distance relay
a). $R_{seen} = f(Q_{GCSC})$, b). $X_{seen} = f(Q_{GCSC})$

VI. CONCLUSION

The results are presented in relation to a typical 220 kV single electrical transmission system employing different GCSC (10 MVar/10 kV, 50 MVar/20 kV and 70 MVar/30kV). The compensator is connected at the midpoint of a protected transmission line by distance relay.

The simulation results show the direct impact on the total impedance of a protected line for different injected variable parameters X_{GCSC} , V_{GCSC} and Q_{GCSC} of the compensator. As can be seen the resistance R_{seen} and reactance X_{seen} respectively in the presence of GCSC and in case of earth fault with resistance fault R_F varied between 5 to 50 Ω at the end of the transmission line are affected. Therefore distance relay tripping characteristic depends on many factors including the power system structural and the pre-fault condition, the earth fault resistance, and parameters of reactance injected by GCSC based the maximum reactive power injected on electrical transmission line.

APPENDIX

A. Power Source: $U_s = 11$ kV, $f_n = 50$ Hz.

B. Power transformer: $U_{TR} = 11 / 220$ kV, $S_{TR} = 200$ MVA.
 $X_{TR1} = j 0,213 \Omega$, $X_{TR0} = j 0,710 \Omega$,

C. Electrical transmission line: $U_L = 220$ kV, $l_L = 117$ km,
 $Z_1 = 0,1213 + j 0,4227 \Omega/\text{km}$, $Z_0 = 0,3639 + j 1,2681 \Omega/\text{km}$.

D. GCSC study:

Case no. 1: $Q_{Max} = 30$ MVar, $V_{Max} = 10$ kV, $X_{C,Max} = 3,333 \Omega$,
Case no. 2: $Q_{Max} = 50$ MVar, $V_{Max} = 20$ kV, $X_{C,Max} = 8,000 \Omega$,
Case no. 3: $Q_{Max} = 70$ MVar, $V_{Max} = 30$ kV, $X_{C,Max} = 12,857 \Omega$.

REFERENCES

- [1] G. Ziegler, *Numerical Distance Protection: Principles and Applications*, 3rd edition, Publics Corporate Publishing, Germany, June 2008.
- [2] AREVA T& D, *Network Protection & Automation Guide*, 2nd Edition, Published by AREVA, Paris, France, January 2010.
- [3] K. K. Sen, and M. L. Sen, *Introduction to FACTS Controllers: Theory, Modeling and Applications*, John Wiley & Sons, Inc., and IEEE Press, New Jersey, USA, January 2009.
- [4] A. N. Abdel-Latif, A. F. Abdel-Gawad, and M. E. Mandour, "Mitigation the Effect of TCSC on the Transmission Lines Protection Devices," in *Proc. 42nd International Universities Power Engineering Conference (UPEC)*, Brighton, UK, 4-6 September 2007.
- [5] M. Khederzadeh, and T. S. Sidhu, "Impact of TCSC on the Protection of Transmission Lines," *IEEE Transactions on Power Delivery*, vol. 21, no. 1, pp. 80-87, January 2006.
- [6] T. S. Sidhu, and M. Khederzadeh, "TCSC impact on Communication-aided Distance Protection Schemes and its Mitigation," *IEE Proceedings on Generation, Transmission and Distribution*, vol. 152, no. 5, pp. 714-728, September 2006.
- [7] M. Zellagui, and A. Chaghi, "A Comparative Study of GCSC and TCSC Effects on MHO Distance Relay Setting in Algerian Transmission Line," *International Journal of Engineering and Technology (IJET)*, vol. 2, no. 2, pp. 220-228, February 2012.
- [8] S. Jamali, and H. Shateri, "Locus of Apparent Impedance of Distance Protection in the Presence of SSSC," *European Transaction on Electrical Power (ETEP)*, vol. 21, no.1, pp. 398-412, January 2011.
- [9] A. Shojaei, and S. M. Madani, "Analysis of Measured Impedance by Distance Relay in Presence of SSSC," in *Proc. IET 5th International*

- Conference on Power Electronics, Machines and Drives (PEMD'10)*, Brighton, UK, 19-21 April 2010.
- [10] M. V. Sham, and K. Panduranga Vittal, "Simulation Studies on the Distance Relay Performance in the Presence of STATCOM," *Journal of Electrical Engineering (JEE)*, vol. 11, no. 3, March 2011.
- [11] Q. Liu, Z. Wang, and Y. Zhang, "Study on a Novel Method of Distance Protection in Transmission Line with STATCOM," in *Proc. Power and Energy Engineering Conference (APPEEC'2010)*, China, 28-31 March, 2010.
- [12] W. H. Zhang, S. J. Lee, M. S. Choi, and S. Oda, "Considerations on Distance Relay Setting for Transmission Line with STATCOM," in *Proc. IEEE Power and Energy Society General Meeting, USA*, 25-29 July 2010.
- [13] F. A. Albasri, T. S. Sidhu, and R. K. Varma, "Performance Comparison of Distance Protection Schemes for Shunt-FACTS Compensated Transmission Lines," *IEEE Transactions on Power Delivery*, vol. 22, no. 4, pp. 2116-2125, October 2007.
- [14] S. Jamali, A. Kazemi, and H. Shateri, "Measured Impedance by Distance Relay for Inter Phase Faults in the Presence of SVC on Double-circuit Lines," in *Proc. IET 11th Conference on Developments in Power System Protection (DPSP'2012)*, Birmingham, UK, 23-26 April 2012.
- [15] J. G. Agrawal, and K. D. Joshi, "Experimental Study of Some Variable Impedance Type FACTS Devices," in *Proc. 4th International Conference on Emerging Trends in Engineering & Technology (ICETET'11)*, Nagpur, India, 18-20 November, 2011.
- [16] L. F. W. de Sow, E.H. Watanabe, and M. Aredes, "GTO Controlled Series Capacitors: Multi-module and Multi-pulse Arrangements," *IEEE Transaction on Power Delivery*, vol. 15, no. 2, pp. 725-731, April 2000.
- [17] K. K. Sen, and M. L. Sen, *Introduction to FACTS Controllers: Theory, Modeling and Applications*, John Wiley & Sons, Inc., and IEEE Press, New Jersey, USA, April 2009.
- [18] M. Zellagui, and A. Chaghi, "MHO Distance Relay of Transmission Line High Voltage using Series Compensation in Algerian Networks," *Journal of ACTA Electrotehnica*, vol. 52, no. 3, pp. 126-133, Oct. 2011.
- [19] L. Gérin-Lajoie, "A MHO Distance Relay Device in EMTP Works," *Electric Power Systems Research*, vol. 79, no.3, pp. 484-49, Mar. 2009.
- [20] D. Sweeting, "Applying IEC 60909, Short-circuit Current Calculations", in *Proc. 58th Annual IEEE, Record of Conference Papers Industry Applications Society*, USA, 19-21 September 2011.
- [21] Ha Heng Xu, and Zhang BaoHui, "Study on Reactance Relays for Single Phase to Earth Fault on EHV Transmission Lines," in *Proc. IEEE International Conference on Power System Technology (PowerCon'04)*, Singapore, 21-24 November 2004.
- [22] C. L. Fortescue, "Method of Symmetrical Coordinates Applied to the Solution of Polyphase Networks," *Transaction AIEE*, pt. II, no. 37, pp.1027-1140, 1918.
- [23] S. Jamali, and H. Shateri, "Impedance Based Fault Location Method for Single Phase to Earth Faults in Transmission Systems," in *Proc. 10th IET International Conference on Developments in Power System Protection (DPSP'10)*, Manchester, UK, 29 March - 1 April, 2010.
- [24] Sonelgaz Group/GRTE, *Electrical Networks High Voltage 220 kV*, Company of Electrical Transmission, Algeria, 30 December 2011.

A. Chaghi was born in Batna, Algeria, 1954. He received his BS degree from the University of Oran, Algeria 1980, and MS from the Manchester University, England 1984, and received his PhD degree in electrical engineering from Batna University, Algeria 2004. He is currently a Professor at department of Electrical Engineering and member LSP-IE research laboratory at University of Batna. His areas of interest include power systems optimization, power system protection, power quality and FACTS devices.

M. Zellagui was born in Constantine, Algeria, 1984. He received the engineer and M.S degree in electrical engineering (electrical networks) from department of electrical engineering at University of Constantine, Algeria in 2007 and 2010 respectively, PhD Student and researcher at LSP-IE research laboratory from department of electrical engineering at Batna University, Algeria. Membership at International Association of Engineers (IAENG), and the Institution of Engineering and Technology (IET). His areas of interest include electrical networks, power system protection, MHO distance relay, Short-circuit and FACTS devices.