

# Image Compression Using Hybrid Vector Quantization

S.Esakkirajan, T. Veerakumar, V. Senthil Murugan and P.Navaneethan

**Abstract**—In this paper, image compression using hybrid vector quantization scheme such as Multistage Vector Quantization (MSVQ) and Pyramid Vector Quantization (PVQ) are introduced. A combined MSVQ and PVQ are utilized to take advantages provided by both of them. In the wavelet decomposition of the image, most of the information often resides in the lowest frequency subband. MSVQ is applied to significant low frequency coefficients. PVQ is utilized to quantize the coefficients of other high frequency subbands. The wavelet coefficients are derived using lifting scheme. The main aim of the proposed scheme is to achieve high compression ratio without much compromise in the image quality. The results are compared with the existing image compression scheme using MSVQ.

**Keywords**—Lifting Scheme, Multistage Vector Quantization and Pyramid Vector Quantization.

## I. INTRODUCTION

THE fundamental goal of image compression is to reduce the bit rate for transmission or image storage while maintaining an acceptable image quality. Due to the advent of multimedia computing, the demand for storage and transmission of images has increased rapidly, their storage and manipulation in raw form is very expensive, and it significantly increases the transmission time and makes storage costly. Wavelet coders for images have been implemented by Antonini and Daubechies [1]. Compactly supported wavelets are typically constructed from a compactly supported scaling function that generates a multi-resolution analysis. Vetterli and Herley [2] proposed a method for constructing wavelet through filter banks. In order to develop new wavelets and reduce the number of wavelet decompositions and reconstructions required by Mallat's algorithm [3], a new technique known as lifting scheme was first introduced and developed by Sweldens [4].

Vector quantization (VQ) is a mapping from a  $k$ -

dimensional Euclidean space to a finite subset of that space. This finite subset is a collection of vectors called code vectors. Codebook is nothing but collection of code vectors. Ideally the codebook should completely reflect the statistics of the input vectors. A complete VQ codec has two parts: an encoder which takes in an incoming vector and finds the best match of all the vectors in the code book for the incoming vector, based on some distortion criterion, and a decoder which receives the address of the best match code vector transmitted by the encoder and then access the same code vector from an identical codebook. Compression is achieved since transmitting the address or indices require a fewer number of bits than transmitting the vector itself.

The goal of VQ codebook generation is to find an optimal codebook that yields the lowest possible distortion when compared with all other codebooks of the same size. VQ performance is directly proportional to the codebook size and the vector size. According to Shannon's rate distortion theory [5] larger vectors would result in better VQ performance. However, with increased vector size the required codebook size also increase, and that in-turn results in an exponential increase in encoding complexity. In this paper we have used MSVQ and PVQ. MSVQ [6] is a product code algorithm. In the MSVQ algorithm [7], except the first stage, the input to the successive stage is the residual vector from the previous stage. Pyramid vector quantization is a form of vector quantization that does not require large codebook storage and has simple systematic encoding and decoding algorithms. A PVQ can be constructed based on a subset of the points in the cubic lattice. It produces efficient compression for higher dimension vectors taken from the subband images.

This paper is organized as follows. A brief review of discrete wavelet transform through lifting scheme is presented in Section II. The multistage vector quantization and the pyramid vector quantization schemes are given in Section III. Pyramid Vector Quantization algorithm is given in Section IV. The proposed hybrid quantization scheme for image compression is presented in Section V. Simulation results and discussions are given in Section VI and finally conclusions are drawn in Section VII.

## II. LIFTING SCHEME

Manuscript received March, 2007.

S. Esakkirajan is working as a Lecturer, in the Department of Electrical and Electronics Engineering, PSG College of Technology, Coimbatore, India. (corresponding author to provide phone: 91-422-2572177; e-mail: rajanesakki@yahoo.com).

T. Veerakumar is working as a Lecturer, in the Department of Electronics and Communication Engineering, PSG College of Technology, Coimbatore, India. (e-mail: tveerakumar@yahoo.co.in).

V. Senthil Murugan is with Mahindra and Mahindra, India (e-mail: senthilmurugan\_eee@yahoo.co.in).

Dr. P. Navaneethan is working as a Professor, in the Department of Electrical and Electronics Engineering, PSG College of Technology, Coimbatore, India.

Wavelet transform has been accepted as a powerful tool for data compression [8]. The wavelet representation is efficient because images are often modeled as a set of locally smooth regions separated by edges. Within these smooth regions, fine-scale wavelet coefficients are small, and coefficients decay rapidly from coarse to fine scales. In the neighborhood of

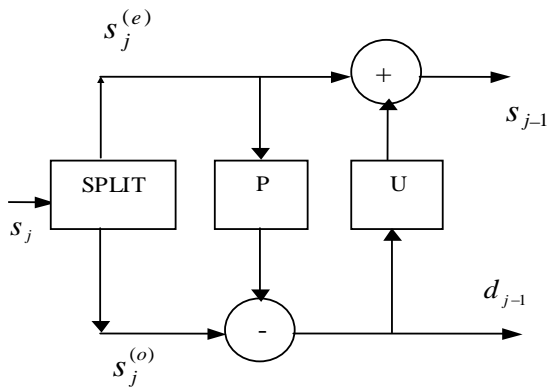

Fig. 1 Forward Lifting Scheme

edges wavelet coefficients decay much more slowly, but because of the local support relatively few coefficients are affected by edges. The design of optimal wavelet filters is required for successful data compression. Daubechies has designed compactly supported orthogonal wavelet [9]. In 1995 Swelden proposed a new approach to construct biorthogonal wavelet filters called a lifting scheme, a novel way to construct biorthogonal wavelets. By making use of similarities between the high and low pass filters, the lifting scheme reduces the computational complexity by a factor of two compared with traditional wavelet transform algorithms. Lifting scheme enables fast construction of perfect reconstruction filter banks. The main difference from classical construction is that the construction is entirely performed in the spatial domain. A typical lifting stage is comprised of three steps Split, Predict and Update as illustrated in Fig. 1.

In the split stage, the original signal  $s_j$  is splitted into its even and odd samples  $s_j^{(e)}$  and  $s_j^{(o)}$  respectively. The detail coefficients are computed as a prediction error of odd samples from even ones, thus contain high frequency information. The approximation coefficients  $s_{j-1}$  are computed from  $s_j^{(e)}$  and  $d_{j-1}$  using update. The idea in choosing update is that  $s_{j-1}$  have the same average value as  $s_j$ .

Forward lifting transform is done by applying the following steps

$$\text{Split: } s_j \rightarrow s_j^{(e)}, s_j^{(o)}$$

$$\text{Predict: } d_{j-1} = s_j^{(o)} - [P\{s_j^{(e)}\} + 0.5]$$

$$\text{Update: } s_{j-1} = s_j^{(e)} + [U\{d_{j-1}\} + 0.5]$$

In the inverse lifting transform as shown in Fig. 2, the following steps are applied

$$\text{Undo Update: } s_j^{(e)} = s_{j-1} - [U\{d_{j-1}\} + 0.5]$$

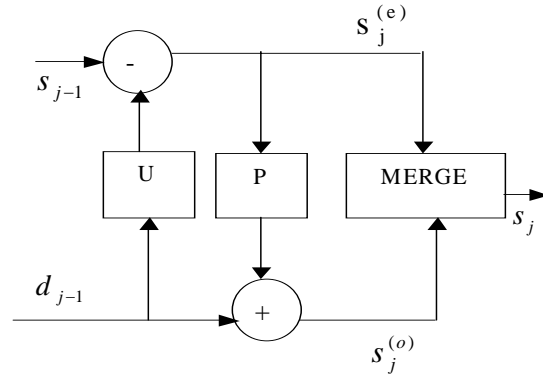

Fig. 2 Inverse Lifting Scheme

$$\text{Undo Predict: } s_j^{(o)} = d_{j-1} + [P\{s_j^{(e)}\} + 0.5]$$

$$\text{Merge: } s_j^{(e)}, s_j^{(o)} \rightarrow s_j$$

In this paper we have implemented 'HAAR' wavelet using lifting scheme. The predictor and updatator values chosen are 1 and 0.5 respectively.

### III. VECTOR QUANTIZATION

Vector quantization [10] is a generalization of scalar quantization in which group of samples is treated as one unit. Vector quantization has been successfully applied to the wavelet-transformed coefficients, resulting in high quality image compression. An iterative design algorithm was proposed by Linde, Buzo, and Gray (LBG) [11] for generating locally optimal VQ. The VQ based on the LBG algorithm has little discernible structure. This unstructured VQ yields an encoding and storage complexities of the order of  $2^{RL}$  and, consequently, it may be prohibitive in practice for many applications of large vector dimensions or high encoding rates. In multistage vector quantization, the input is quantized in several stages. The first stage performs a relatively crude encoding of the input vector using a small code book. Then, a second-stage quantizer operates on the error vector between the original vector and the quantized first stage output. The quantized error vector provides a refinement to the first approximation. At the decoder, the reproduction vectors produced by the first and second stages will be added together. Additional stages of quantizers can provide further refinements. Unlike full-search VQ, whose encoding complexity and memory requirements increase exponentially with the dimension-rate product, in multistage VQ, the increase is only linear [12]. This has particular utility in subband coding since either the rate or the dimension can be made large, which allows it to respond to the occasional need for locally high bit rate in subband coding. The formulation of

the MSVQ leads to a reduction of codebook search and storage complexity and also a significant reduction in the

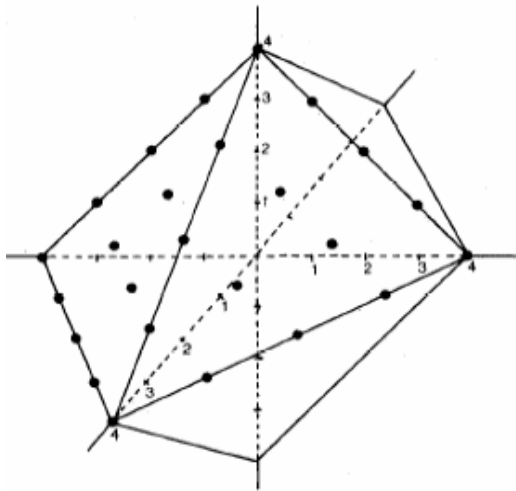

Fig. 3 Pyramid in three-dimensional plane

encoding performance [13].

Pyramid vector quantization uses the lattice points [14] of a pyramidal shape in multidimensional space as the quantizer codebook. PVQ was introduced by Fischer [15] as a fast and efficient method of quantizing Laplacian-like data, such as generated by transforms or subband filters in an image compression system. It combines the robustness of fixed-rate codes with the performance of entropy-coded scalar quantization. PVQ takes its name from the geometric shape of the points in its codebook. It is designed for Laplacian random variables, whose equiprobable contours form multidimensional pyramids. The multidimensional Laplacian probability density is given by

$$f_X(x) = (\lambda/2)^m e^{-\lambda \sum_{i=1}^m |x_i|} \quad (1)$$

where  $x$  is a vector of length 'm'. The surfaces of equal probability is defined in an 'm' dimension space where the  $l_1$  norm of  $x$  is a constant,  $r$ , representing the radius of the surface

$$\sum_{i=1}^l |x_i| = r \quad (2)$$

The surface given by a fixed  $l_1$  constraint on the coordinates is called a pyramid. The radial distribution for 'r' can be obtained from the convolution of 'l' exponential distributions which is given by

$$f_R(r) = \frac{\lambda^l r^{l-1} e^{-\lambda r}}{(l-1)!} \quad (3)$$

The PVQ codebook,  $P(l, k)$ , consists of the set of integer vectors of length  $l$  whose absolute values sum to  $k$ :  $P(l, k) = \{x : x_i \in \mathbb{Z} \text{ and } \sum |x_i| = k\}$ . In the case of

two-dimensional vectors the pyramid or the radius of constant probability density looks like a rhombus. In the case of three-dimensional vectors the pyramid can be easily visualized. The pyramid with a dimension of three and a norm of four is shown in Fig. 3. The PVQ codebook,  $P(l, k)$ , is typically

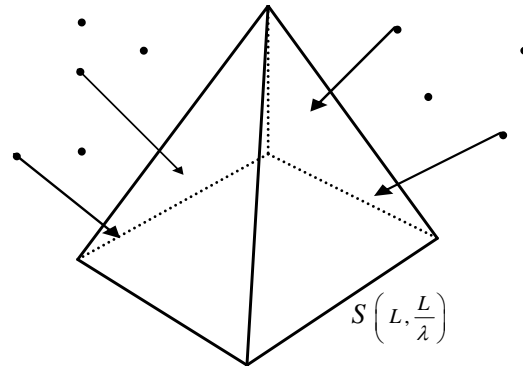

Fig. 4 Projection of vectors on the surface of the pyramid

scaled to fit the desired pyramid contour.

Enumeration assigns a unique index to all possible vectors in the PVQ code book,  $P(l, k)$ , imparting a sorting order to the PVQ codebook vectors. In this paper we have implemented magnitude enumeration technique introduced by Fischer [15].

#### IV. PYRAMID VECTOR QUANTIZATION ALGORITHM

The algorithm of Pyramidal Vector Quantization is given below

1. All the vectors (having dimension of  $L$ ) taken from the wavelet transformed images are projected on the surface of the pyramid such that the projection yields the least mean squared error. This is shown in Fig. 4.

2. The vectors lying on the surface of the pyramid are then scaled to an inner pyramid with a scaling factor of 'Y' where the inner pyramid is chosen based on the rate criterion 'R' bits/dimension.

3. Choosing the inner pyramid: To encode the  $L$ -dimensional vectors obtained from the sub-band images at a specified rate per dimension namely  $R$  bits/dimension, the largest value of  $K$  should be found such that the following condition is satisfied:

$$N(L, K) \leq 2^{RL}$$

$N(L, K)$  represents the number of code vectors on the surface of the chosen pyramid which meets the rate criterion of  $R$  bits/dimension.  $N(L, K)$  represents the number of vectors with integer components satisfying a norm of  $K$ .

$$N(L, K) = \left\{ \sum_{i=1}^L |x_i| = K \right\}$$

and  $x_i$  is an integer, for  $i = 1, \dots, L$ . For  $K=1$ , only one of the  $x_i$  in the above equation is non-zero, with value either 1 or -1. Hence  $N(L, 1) = 2L$ . Conversely,

If  $L=1$ , then  $x_i$  is either  $K$  or  $-K$ , so that  $N(1, K) = 2$ . Using a combinational argument  $N(L, K)$  is found to satisfy the recursive formula:

$$N(L, K) = N(L-1, K) + N(L, K-1) + N(L-1, K-1)$$

for  $L \geq 2$  and  $K \geq 2$ .

Since  $N(1, K)$  and  $N(L, 1)$  are known, it is simple to compute  $N(L, K)$ . The complete proof of the recursive formula for calculation of  $N(L, K)$  was discussed by Fischer [15].

4. Find the code vector (the set of code vectors is given by  $N(L, K)$ ) nearest to the scaled vector on the  $S(L, K)$  lattice. Geometrically  $S(L, K)$  is the surface of the hyper pyramid in  $L$ -dimensional space.

5. Find the index of the code vectors generated, based on the magnitude enumeration algorithm.

## V. PROPOSED ALGORITHM

The proposed algorithm is given below

(1) The correlation in the test image is removed by wavelet transform. Wavelet transform is implemented through lifting scheme. The wavelet implemented through lifting scheme is HAAR wavelet.

(2) The first level of decomposition yields four components namely LL, LH, HL and HH respectively. Multistage vector quantization is applied to LL band. The detail coefficients in the subband LH, HL and HH are pyramidal vector quantized by taking vectors of specified dimension.

(3) An entropy coding algorithm such as Huffman coding is applied as the last stage of the compression scheme to code the indices.

The encoder of the proposed scheme is shown in Fig. 5. The proposed algorithm posses the advantage of reduction of codebook searches and storage complexity which is inherent to MSVQ [16]. Moreover pyramid vector quantization does

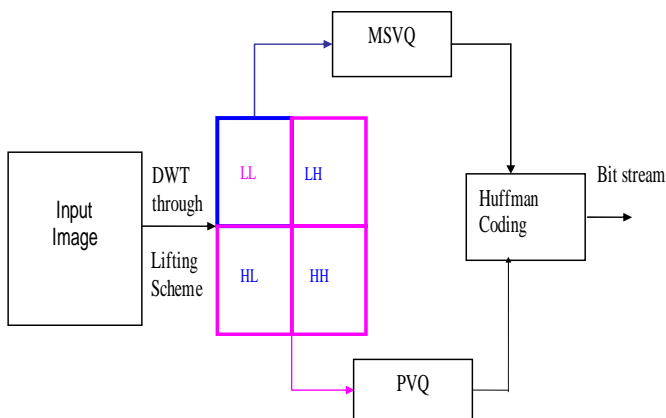

Fig. 5 Encoder of the Proposed Scheme

not require large codebook storage and that has simple encoding and decoding algorithm. Hence high compression ratio can be achieved by incorporating PVQ along with MSVQ.

## VI. RESULTS AND DISCUSSION

We have tested our algorithm for three different types of images namely 'LENA', 'GOLDHILL' and 'HOUSE'. LENA image do not contain large amounts of high frequency or oscillating patterns. GOLDHILL image contains significant amounts of both low and high frequency regions. HOUSE image is characterized by large amount of high-frequency information. We present the encoding results of 256 x 256, 8 bit resolution LENA, GOLDHILL and HOUSE images with two stages in MSVQ and the dimension of PVQ chosen is sixteen.

We have compared the performance of the proposed hybrid quantization scheme with MSVQ. When LENA image was encoded at low bit rate, the PSNR obtained using hybrid

TABLE I  
RESULTS OF THE PROPOSED SCHEME FOR LENA IMAGE

Dimension = 16	Level of Decomposition=1		Level of Decomposition = 2		Level of Decomposition = 3	
	PSNR in dB	Compression Ratio	PSNR in dB	Compression Ratio	PSNR in dB	Compression Ratio
Rate 1	25.28	22.50	22.70	28.75	20.36	31.60
Rate 2	27.52	6.97	23.82	11.03	21.02	13.22
Rate 4	27.71	4.86	23.90	9.39	21.06	12.39
Rate 8	27.72	3.73	23.91	8.18	21.07	11.88

quantization scheme is better than MSVQ, which is evident from Table I, and Table II respectively. At high bit rate, MSVQ dominates the hybrid quantization scheme with respect to image quality with less compression ratio. From Table I and II it is evident that high compression ratio can be achieved in hybrid quantization scheme than applying only MSVQ. A plot of PSNR against rate for LENA image is given in Fig. 6. As the rate increases, the PSNR increases which is in accordance with Rate-Distortion theory. The original and the reconstructed LENA image using proposed scheme and MSVQ scheme for the first level of decomposition, rate as eight and dimension as sixteen is shown in Fig. 9.

TABLE II  
RESULTS OF THE MSVQ SCHEME FOR LENA IMAGE

Dimension = 16	Level of Decomposition=1		Level of Decomposition = 2		Level of Decomposition = 3	
	PSNR in dB	Compression Ratio	PSNR in dB	Compression Ratio	PSNR in dB	Compression Ratio
Rate 1	23.21	13.42	19.95	14.41	17.44	14.43
Rate 2	27.93	6.28	23.58	7.42	20.07	7.59
Rate 4	28.40	3.52	23.80	4.00	20.19	4.07
Rate 8	28.44	2.56	23.81	2.84	20.20	2.90

Table III and IV shows the performance of the hybrid quantization and MSVQ scheme when applied to GOLDHILL image. From the tables, it is evident that the compression ratio

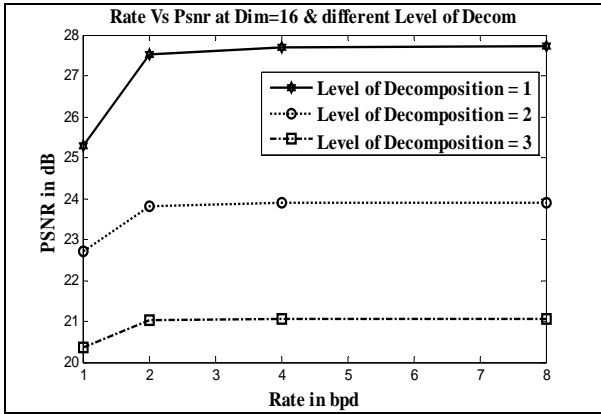

Fig. 6 Rate distortion curve for LENA image for different levels of decomposition

obtained using hybrid quantization scheme is almost double to that MSVQ scheme. A plot of compression ratio against rate for GOLDHILL image is shown in Fig. 7. From the plot, it is evident that the proposed hybrid quantization scheme outperforms MSVQ, with respect to compression ratio at both low and high bit rate. The original and the reconstructed

TABLE III  
RESULTS OF THE PROPOSED SCHEME FOR GOLDHILL IMAGE

Dimension = 16	Level of Decomposition = 1		Level of Decomposition = 2		Level of Decomposition = 3	
	PSNR in dB	Compression Ratio	PSNR in dB	Compression Ratio	PSNR in dB	Compression Ratio
Rate 1	26.49	24.59	24.21	35.07	22.09	40.01
Rate 2	29.90	8.76	25.89	14.74	23.07	18.38
Rate 4	30.26	5.58	26.02	11.80	23.14	16.78
Rate 8	30.26	4.24	26.03	10.07	23.14	15.87

GOLDHILL image using the proposed scheme and the MSVQ scheme for the third level of decomposition, the rate as two and the dimension as sixteen is shown in Fig. 10.

The result of the hybrid quantization scheme and MSVQ scheme for HOUSE image is shown in Table V and VI respectively. The compression ratio achieved using the proposed hybrid compression scheme is almost double to that

TABLE IV  
RESULTS OF THE MSVQ SCHEME FOR GOLDHILL IMAGE

Dimension = 16	Level of Decomposition = 1		Level of Decomposition = 2		Level of Decomposition = 3	
	PSNR in dB	Compression Ratio	PSNR in dB	Compression Ratio	PSNR in dB	Compression Ratio
Rate 1	25.81	12.77	22.45	13.28	19.67	13.34
Rate 2	29.96	5.56	24.77	6.25	20.91	6.39
Rate 4	30.41	3.24	24.93	3.59	20.99	3.66
Rate 8	30.45	2.60	24.95	2.86	20.99	2.91

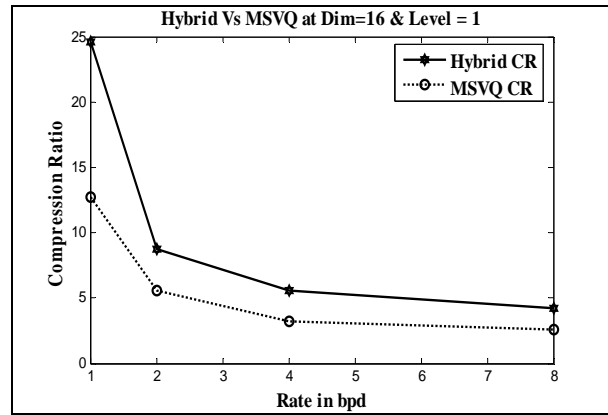

Fig. 7 Rate distortion curve of the proposed scheme against MSVQ for GOLDHILL image

TABLE V  
RESULTS OF THE PROPOSED SCHEME FOR HOUSE IMAGE

Dimension = 16	Level of Decomposition = 1		Level of Decomposition = 2		Level of Decomposition = 3	
	PSNR in dB	Compression Ratio	PSNR in dB	Compression Ratio	PSNR in dB	Compression Ratio
Rate 1	25.71	29.73	23.34	39.80	21.01	44.35
Rate 2	28.24	9.16	24.65	15.60	21.75	19.37
Rate 4	28.47	5.73	24.75	12.10	21.80	17.25
Rate 8	28.49	4.22	24.76	10.13	21.81	16.14

of compression ratio achieved through MSVQ. A plot of rate against compression ratio for different levels of decomposition for HOUSE image is given in Fig. 8. From the plot it is evident that as the level of decomposition increases, the compression ratio increases at the expense of image quality. The original and the reconstructed HOUSE image

TABLE VI  
RESULTS OF THE MSVQ SCHEME FOR HOUSE IMAGE

Dimension = 16	Level of Decomposition = 1		Level of Decomposition = 2		Level of Decomposition = 3	
	PSNR in dB	Compression Ratio	PSNR in dB	Compression Ratio	PSNR in dB	Compression Ratio
Rate 1	23.69	14.37	20.91	15.22	18.53	15.12
Rate 2	27.93	6.28	23.58	7.42	20.07	7.59
Rate 4	28.40	3.52	23.80	4.00	20.19	4.07
Rate 8	28.44	2.56	23.81	2.84	20.20	2.90

using the proposed scheme and the MSVQ scheme for the second level of decomposition, the rate as six and the dimension as sixteen is shown in Fig. 11.

We have also tested our algorithm by varying the dimension of PVQ and the corresponding result is given in Table VII for GOLDHILL image. From the table it is clear that as the dimension increases, the compression ratio increases. At the second and third level of decomposition, it is

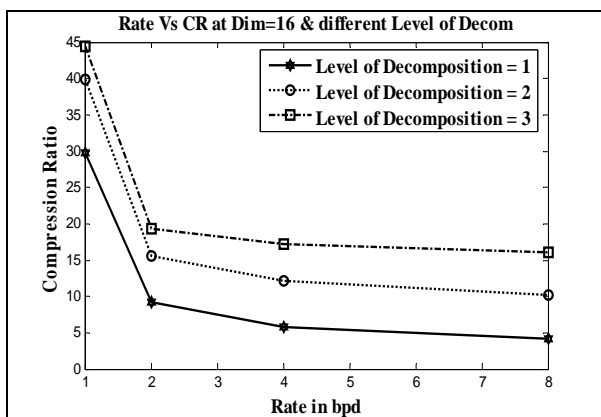

Fig. 8 Rate distortion curve for the HOUSE image for different levels of decomposition

not possible to get the vector of dimension of 128, which is illustrated by '-' in the Table VII.

The superior performance of the proposed method can be explained by the following reasons. First, VQ is a block length coding method, which can approach the entropy rate

TABLE VII  
RESULTS OF THE PROPOSED SCHEME FOR DIFFERENT DIMENSIONS IN PVQ

Rate = 4	Level of Decomposition=1		Level of Decomposition = 2		Level of Decomposition = 3	
	PSNR in dB	Compr ession Ratio	PSNR in dB	Compr ession Ratio	PSNR in dB	Compr ession Ratio
2	30.22	3.87	26.01	4.47	23.13	4.64
4	30.22	3.82	26.01	4.78	23.13	5.18
8	30.23	4.53	26.01	7.12	23.13	8.46
16	30.24	5.58	26.02	11.80	23.14	16.78
32	30.24	6.30	26.01	17.35	23.14	32.05
64	30.26	6.69	26.04	21.94	-	-
128	30.27	6.88	-	-	-	-

more effectively than the scalar coding. Second, vector quantization uses the correlation within vector to improve quantization efficiency and reduce quantization errors. PVQ can encode large-dimensional vectors, hence it is possible to achieve high compression ratio with minimum distortion. MSVQ can achieve very low encoding and storage complexity hence it is applied to the low frequency component of the input image. The proposed algorithm performs competitively with known state-of-the art compression technique.

## VII. CONCLUSION

A new compression algorithm with two quantization techniques is introduced in this paper. In this paper we focus on image compression based on hybrid quantization scheme. The proposed method enables high compression bit rates while maintaining good visual quality. MSVQ is particularly efficient in the coding of texture dominant images which are more difficult to encode by traditional coding methods. The penalty we are paying for using MSVQ is that of a marginally

reduced PSNR is overcome by employing PVQ. We have compared the performance of the proposed scheme with image compression using MSVQ. The proposed scheme outperforms MSVQ with respect to compression ratio both at low and high bit rates. However, MSVQ yields better PSNR at high bit rate, at the expense of compression ratio. The performance of the proposed scheme can be improved further by incorporating different enumeration algorithms in PVQ, by including more stages in MSVQ.

## ACKNOWLEDGMENT

The authors wish to thank their teachers Dr. S. Jayaraman, Dr. N. Malmurugan, and Mr. R. Sudhakar for their continued support and encouragement. The authors are thankful to our well-wishers Mr. D. Sivaraj and Ms. Kavitha. They also thank their present institution where they are working.

## REFERENCES

- [1] M. Antonini, and I. Daubechies, "Image coding using wavelet transform," IEEE Trans. Image Processing, vol.1, no.2, pp.205-220, Apr. 1992.
- [2] M.Vetterli, and C.Herley, "Wavelets and filters: theory and design," IEEE Trans. Signal Process., vol.40, no.12, pp.2207-2232, 1992.
- [3] S.G. Mallat, "Multiresolution approximation and wavelet orthogonal base of  $L^2(\mathbb{R})$ ", Trans.Am.Math.Soc., vol.315, no.1, pp.68-88, 1989.
- [4] W. Sweldens, "The lifting scheme: A custom-design construction of biorthogonal wavelets," Applied and Computational Harmonic Analysis, vol.3, no.2, pp.186-200, Apr. 1996.
- [5] C. E. Shannon, "A mathematical theory of communication," Bell Sys. Tech. Journal, vol. 27, pp. 379-423, 1948.
- [6] B. H. Juang and A. H. Gray, "Multiple stage vector quantization for speech coding," Proc. IEEE ICASSP, pp.597-600, Apr. 1982.
- [7] S. Esakkirajan, T. Veerakumar, V. Senthil Murugan and R. Sudhakar, "Fingerprint Compression using Contourlet Transform and Multistage Vector Quantization," IJBS, vol. 1, No.2, 2006.
- [8] T. Strutz and E.Muller, "Image Data Compression with Pdf-Adaptive Reconstruction of Wavelet Coefficients," Proceedings of SPIE, vol.2569, pp.747-758, July 1995.
- [9] I. Daubechies, "Orthonormal Bases of Compactly Supported Wavelets," Comm. Pure Appl. Match., vol.XLIV, pp.909-996, Novemeber 1988.
- [10] A. Gersho and R. Gray, "Vector Quantization and Signal Compression", Kluwer Academic Publishers, M.A, 1995.
- [11] Y. Linde, A. Buzo, and R.M. Gray, "An algorithm for vector quantizer design," IEEE Trans. Commun., vol. COMJ-28, pp.84-95, Jan.1980.
- [12] Pamela C. Cosman and Robert M.Gray, "Vector Quantization of Image Subbands: A Survey," IEEE Trans. Image Processing, vol.5, no.2, pp. 202-225, February 1996.
- [13] Jianping Pan, "Extension of Two-Stage Vector Quantization-Lattice Vector Quantization", IEEE Trans. Communications, vol.45, no.12, pp.1538-1547, Dec.1997.
- [14] M. Antonini, P. Sole, T.Gordon and M.Barlaud, "Pyramidal lattice vector quantization for multiscale image coding", IEEE Trans. Image processing, vol.3, pp.367-381, 1994.
- [15] T. R. Fischer, "A pyramid vector quantizer," IEEE Trans. Inform. Theory, vol.32, pp.568-583, July 1986.
- [16] Jayshree Karlekar, P. G. Poonacha and U. B. Desai, "Image Compression using Zerotree and Multistage Vector Quantization", ICIP, vol.2, no.2, 1997.

S. Esakki rajan received his Bachelor of Science degree from Sadakathullah Appa College, Palayamkottai, Bachelor of Technology degree from Cochin University of Science and Technology. He received his postgraduate degree from PSG College of Technology. He is currently working as a lecturer in Electrical and Electronics Engineering Department, PSG College of Technology, Coimbatore.

T. Veerakumar received his Bachelor of Engineering degree from RVS College of Engineering and Technology, Dindugal. He received his Master of Engineering degree from PSG College of Technology, Coimbatore. He is currently working as a lecturer in Electronics and Communication Engineering Department, PSG College of Technology, Coimbatore.

Dr. P. Navaneethan is currently working as a Professor in Electrical and Electronics Engineering Department, PSG College of Technology, Coimbatore. He received his Bachelor of Engineering degree from Coimbatore Institute of Technology, Master of Engineering from Anna University and doctorate degree from Indian Institute of Science, India.

V. Senthil Murugan received his Bachelor of Engineering degree from PSG College of Technology. He is currently working as a design engineer in Mahindra and Mahindra, Nasik, India.

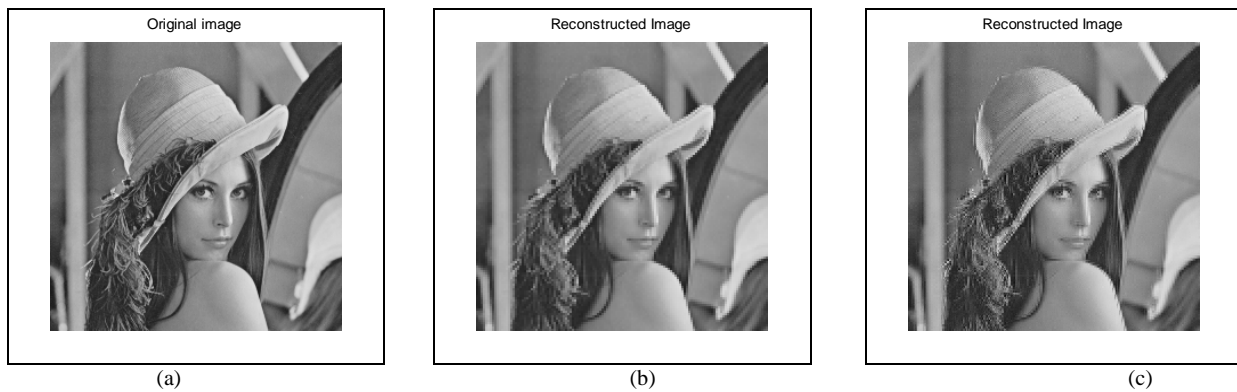

Fig. 9 Original and decoded LENA image

(a) Original Image (b) Decoded image using proposed scheme (c) Decoded image using MSVQ scheme

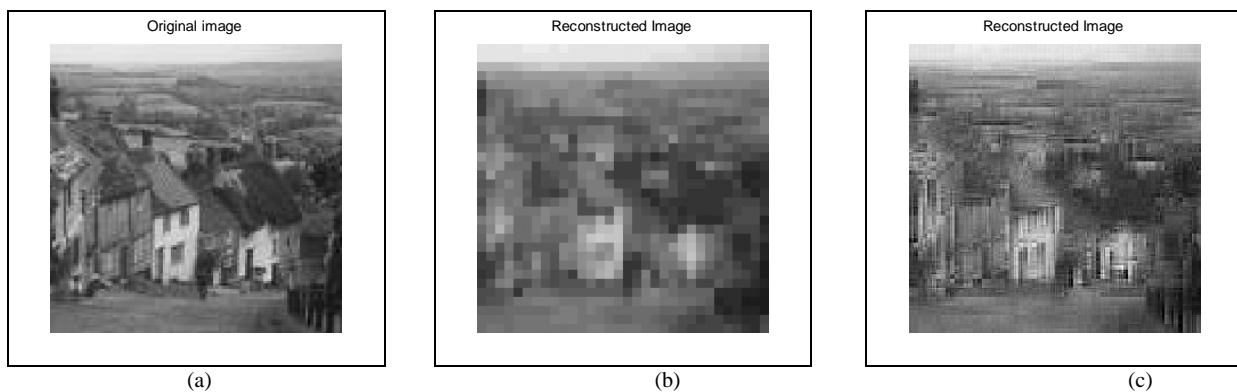

Fig. 10 Original and decoded GOLD HILL image

(a) Original Image (b) Decoded image using proposed scheme (c) Decoded image using MSVQ scheme

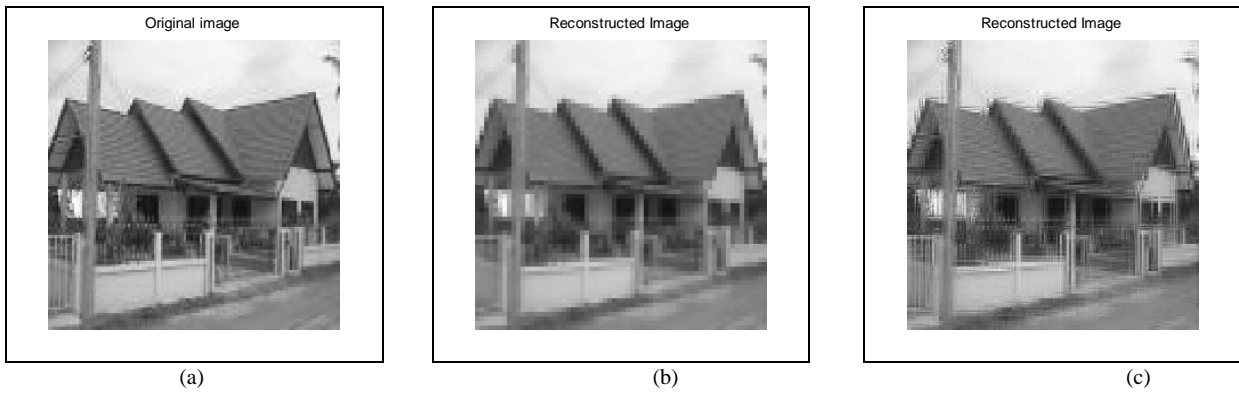

Fig. 11 Original and decoded HOUSE image  
(a) Original Image (b) Decoded image using proposed scheme (c) Decoded image using MSVQ scheme