

# Identification of the Antimicrobial Effect of Liquorice Extracts on Gram-Positive Bacteria: Determination of Minimum Inhibitory Concentration and Mechanism of Action Using a *luxABCDE* Reporter Strain

Madiha El Awamie, Catherine Rees

**Abstract**—Natural preservatives have been used as alternatives to traditional chemical preservatives; however, a limited number have been commercially developed and many remain to be investigated as sources of safer and effective antimicrobials. In this study, we have been investigating the antimicrobial activity of an extract of *Glycyrrhiza glabra* (liquorice) that was provided as a waste material from the production of liquorice flavourings for the food industry, and to investigate if this retained the expected antimicrobial activity so it could be used as a natural preservative. Antibacterial activity of liquorice extract was screened for evidence of growth inhibition against eight species of Gram-negative and Gram-positive bacteria, including *Listeria monocytogenes*, *Listeria innocua*, *Staphylococcus aureus*, *Enterococcus faecalis* and *Bacillus subtilis*. The Gram-negative bacteria tested include *Pseudomonas aeruginosa*, *Escherichia coli* and *Salmonella typhimurium* but none of these were affected by the extract. In contrast, for all of the Gram-positive bacteria tested, growth was inhibited as monitored using optical density. However parallel studies using viable count indicated that the cells were not killed meaning that the extract was bacteriostatic rather than bacteriocidal. The Minimum Inhibitory Concentration [MIC] and Minimum Bactericidal Concentration [MBC] of the extract was also determined and a concentration of 50 µg ml<sup>-1</sup> was found to have a strong bacteriostatic effect on Gram-positive bacteria. Microscopic analysis indicated that there were changes in cell shape suggesting the cell wall was affected. In addition, the use of a reporter strain of *Listeria* transformed with the bioluminescence genes *luxABCDE* indicated that cell energy levels were reduced when treated with either 12.5 or 50 µg ml<sup>-1</sup> of the extract, with the reduction in light output being proportional to the concentration of the extract used. Together these results suggest that the extract is inhibiting the growth of Gram-positive bacteria only by damaging the cell wall and/or membrane.

**Keywords**—Antibacterial activity, bioluminescence, *Glycyrrhiza glabra*, natural preservative.

## I. INTRODUCTION

OVER the last decade, the foodborne pathogens became an increasing concern through food contamination of products, including meat, fresh fruits and vegetables, caused by bacteria such as *Listeria monocytogenes*, *Campylobacter*

*jejuni* and *Escherichia coli* [1]. Health hazards posed by microbial pathogens in food are of major concern to all governments because of circulation of contaminated food between countries increases the chance of outbreaks of foodborne disease. According to International trade statistics (2015) by World Trade Organization (WTO), food represents 42% of total world exports, and levels have increased 6% per year since 2010, and so food is a substantial and increasing area of trade [2]. According to the definition of foodborne illnesses by The World Health Organization (WHO), these are diseases caused by agents that enter the body through the ingestion of food which either infectious or toxic in nature [3]. Approximately 1.8 million deaths were registered in 2005 caused by diarrhoeal disease, and a large proportion of these cases can be attributed to contamination of food and drinking water. However, levels of foodborne disease are generally under-reported and are difficult to measure accurately [4]. Although generally the safety of food has dramatically improved overall, foodborne outbreaks from microbial contamination are still prevalent in many countries, and failure to discover the presence of pathogenic microorganisms especially in the food industry may lead to serious effects on human health [5], [6].

Bacteria such as *Campylobacter*, *Salmonella*, *L. monocytogenes* and *E. coli* are commonly reported to be responsible for foodborne disease and outbreaks [7], [8]. Generally, all these bacterial pathogens are grouped together, but physiologically they are very different, in particular a major structural difference occurring in the different cell types. For instance, *Campylobacter*, *Salmonella* and *E. coli* are all Gram-negative bacteria and have a cells wall structure including two layers of membrane and a thin layer of the structural polysaccharide peptidoglycan (PG). In contrast Gram-positive bacteria, such as *Listeria*, *Staphylococcus*, *Enterococcus* and *Bacillus*, have only one cell membrane encased in a thick layer of PG. Hence when considering the action of new antimicrobial agents, it is important to test them against a range of bacterial cell types.

*L. monocytogenes* is a foodborne pathogen that is almost exclusively transmitted to human through consumption of contaminated food. Its unusual biology – being able to grow

Madiha El Awamie is with the Microbiology and Food Safety, The University of Nottingham, Nottingham, United Kingdom (e-mail: stxma46@nottingham.ac.uk).

equally well in soil or in the GI tract of animals and within food production facilities – means that it is associated with a broad range of ready-to-eat (RTE) foods, including dairy products, fresh vegetables, processed meats and shellfish. Infection by this bacterium results in the disease listeriosis that can have a number of different serious consequences including meningitis, meningo-encephalitis and septicaemia and is distinguished by a high mortality rate of up to 30%. The severity of the diseases caused by this bacterium means that the economic costs associated with an infection is high. For instance, during an outbreak in Canada in 2008 related to consumption of contaminated delicatessen meat, 57 cases of listeriosis were reported, resulting in 24 deaths. The costs associated with the cases (including medical and nonmedical costs and productivity losses) were estimated to be nearly \$242 million Canadian dollars [9]. Infection is generally seen in people with weakened immune systems, including pregnant women, infants, and the elderly and although listeriosis occurs infrequently, it is a major concern for the food industry [10], [11].

There are many challenges exist for the control of *L. monocytogenes* in the food chain, including its ability to survive and grow at low temperatures. Although low temperature is normally used to prevent the growth of bacteria, *L. monocytogenes* has the unusual ability to adapt to low temperature conditions and grow in refrigerated foods. It can also tolerate and grow over a wide range of pH and moisture levels and can form biofilms making it resistant to disinfection. The bacterium can colonize in food production equipment and environments and, consequently, these bacteria have been shown to persist for months to years in food-processing plants, acting as a possible source of cross-contamination of product. Indeed, contamination of food products with *Listeria* has been identified at many different stages of food production including slicing, packaging and chill-storage [12], and therefore many different techniques are employed to inhibit, spread and survival of *L. monocytogenes* in food products. So, the control and elimination of this type of bacteria from food products is the best strategy to ensure food safety [13].

Generally, when testing antimicrobial agents, cells are challenged with the test chemical and the effect measured by the level of growth inhibition observed. Despite the fact that the definition of viability depends on the capacity of bacteria to multiply and divide, growth of bacteria in a liquid medium, or the formation of colonies on solid agar, is not considered sufficient evidence that bacteria are either alive or dead after treatment since antimicrobial agents may simply be bacteriostatic and prevent growth without causing permanent cell damage. To address this, other methods have been developed to report on cellular viability, including enzyme and respiratory activity and measurement of ATP levels. These parameters can also report on sub-lethal damage to cells, factors that affect membrane integrity or require energy for repair will reduce ATP levels but not result in cell death [14], [15].

Bioluminescence is the process by which visible light is emitted by an organism as a result of a chemical reaction catalysed by a luciferase enzyme and this phenomenon is seen in a variety of organisms, such as insects, fish, squid, shrimp, and jellyfish, but is also seen in bacteria. Bacterial luciferase (Lux) is encoded by the *luxAB* genes which catalyse the reduction of a long-chain fatty aldehyde in the presence of molecular oxygen and FMNH<sub>2</sub> and results in the emission of light (Fig. 1 B). Cells encoding the full *lux* operon (Fig. 1 A) generate a bioluminescence phenotype without the need to add any additional cofactors or exogenous substrates [15], [16]. Since FMNH<sub>2</sub> production is dependent on a functional electron transport chain, only metabolically active bacteria emit light and therefore it can be used to rapidly monitor antimicrobial activity [15]. Although many bacteria of interest are not naturally bioluminescent, the *lux* operon can be introduced into a number of different cells on plasmids as long as the genes are engineered to function in that particular cell type [17] and therefore bioluminescence has been widely used to study antimicrobial agents [15], [18].

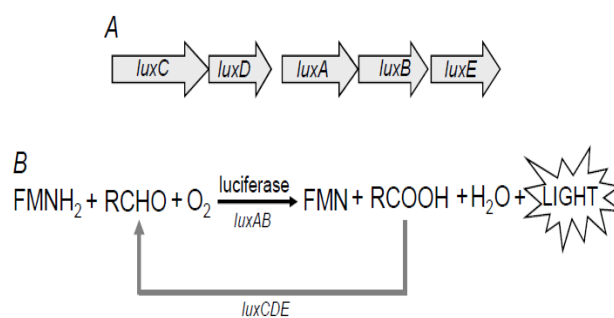

Fig. 1 A) Organisation of the *lux* operon in *Vibrio* and *Photobacterium* species including the luciferase genes *luxA* and *luxB* and the *luxCDE* genes which encode a fatty acid reductase complex that regenerates the long chain aldehyde substrate (luciferin) B) The chemical reaction giving rise to light production in bioluminescent bacteria in which the aldehyde is converted to the carboxylic acid in the presence of oxygen reduced flavin mononucleotide (FMNH<sub>2</sub>); The by-products of this reaction are flavin mononucleotide (FMN) and light in the visible spectrum (bioluminescence)

Another commonly used marker gene is the green fluorescent protein (GFP) produced by the jellyfish *Aequorea victoria* which has become a simple and flexible tool used in many applications in field of molecular biology, medicine and cell biology. The protein is small (27-kDa) and produces green fluorescence at 509 nm when excited with UV light at 398 nm [19], [20]. As GFP protein is extremely stable *in vivo*, it has proved to be useful when studying cells exposed to some sort of stress condition, as the fluorescence signal does not decrease allowing cells to be easily visualised, even if non-viable [21]. Again, bacteria do not naturally produce *Gfp* but this can also be introduced into bacteria on plasmids [22] and can also be introduced onto plasmid in conjunction with the *lux* genes so that cells containing these plasmids are both bioluminescent and fluorescent [23].

## II. MATERIAL AND METHODS

### A. Bacterial Strains, Plasmids, and Growth Conditions

Bacterial strains and plasmids used in this study are listed in Tables I and II, respectively. These strains were transformed with plasmids carrying the bacterial *luxABCDE* and *gfp* genes modified for expression in each of the different bacteria genera used. Strains were recovered Microbank™ beads held at -80 °C by inoculating into Brain Heart Infusion (BHI) broth and then plating onto BHI agar with erythromycin (Erm; 5 µg ml<sup>-1</sup>) to select for the presence of the plasmids. Plates were incubated for 24 h at 37 °C and stored at 4 °C. For each experiment, an isolated colony was inoculated in BHI broth supplements with Erm and incubated at 37 °C for 24 h.

TABLE I  
BACTERIAL STRAINS USED IN THIS STUDY

Bacteria	Strain numbers or source	Gram reaction group
<i>Salmonella enterica</i> serovar Typhimurium	Nottingham lab collection	-ve
<i>Escherichia coli</i>	NCTC 86	-ve
<i>Staphylococcus aureus</i>	Chicken isolate	+ve
<i>Bacillus subtilis</i>	var. Niger 168	+ve
<i>Listeria innocua</i>	Nottingham lab collection	+ve
<i>Listeria monocytogenes</i>	10403S (wild type; 1/2a) EGD (wild type; 1/2a) ATCC 23074(wild type; 4b) NCTC 10357 ( $\Delta prfA$ ) NCTC 7973 ( <i>prfA*</i> )	+ve

TABLE II  
BACTERIA WITH PLASMID USED IN THIS STUDY

Bacteria	Promoter & Insert	Vector	Antibiotic selection [µg ml <sup>-1</sup> ]
<i>L. innocua</i>	BS10, <i>luxABCDE</i> , <i>gfp</i>	pUNK18	Erm [5]
<i>L. monocytogenes</i>	BS10 <i>luxABCDE</i> , <i>gfp</i>	pUNK18	Erm[5]
<i>L. monocytogenes</i> NCTC 10357	<i>xylA</i> , <i>luxABCDE</i> , <i>gfp</i>	pUNK18	Erm [5]

### B. Liquorice Extract

Liquorice extract (3 mg) was weighed into a sterile bijoux bottle then dissolved in 1 ml of 70% (v/v) by incubating at 37 °C 10 min and was then stored at -20 °C prior to use.

### C. Determining Antibacterial Activity of Liquorice Extract

Overnight cultures were prepared and aliquots inoculated into sterile 250 ml Erlenmeyer flasks containing 100 ml of BHI broth. The inoculum of the broth culture was adjusted until the bacterial suspension reached an OD<sub>600nm</sub> 0.05 which was equivalent to an approximately 1x10<sup>7</sup> CFU ml<sup>-1</sup>. Three flasks were prepared for each type of bacteria; the first flask (control) contained 1% (v/v) ethanol, the second flask contained 12.5 µg ml<sup>-1</sup> of liquorice extract and the third flask contained 50 µg ml<sup>-1</sup> of liquorice extract. Ethanol was used as the solvent to dissolve the liquorice extract and therefore ethanol alone (which is known to have antimicrobial activity at high concentration) was used as a control. The concentration of ethanol used was 1% (v/v) as this was the

maximum level of ethanol present in either of the test samples following addition of the liquorice extract. Samples were incubated at 37 °C for 30 min with aeration (shaking at 150 rpm), and samples collected for OD measurement at 30 min intervals for approximately 3 h. In addition, the viable count of the culture was determined for each of the time points using standard dilution and plating methods.

### D. Gram Stain

Cells were imaged using a standard light microscope after Gram-staining using a x100 oil immersion lens. Images were captured using microscope with camera attached to a computer, and also with using electronic microscope connected to a Cannon camera.

### E. Growth in Tecan Microplate Reader

Overnight cultures of bacteria were used to inoculate fresh broth to an OD<sub>600nm</sub> of 0.05. Samples of the cultures (200 µl) were transferred into the wells of a microtitre plate (Krystal Microplate, clear bottom or Porvair 96 well black, Porvair Sciences, England), and samples incubated at 37 °C in a Tecan Genesis Pro microplate reader. Cell growth was monitored by using OD<sub>600nm</sub> with readings taken every 10 min for 24 h. Fluorescence (RFU; Excitation wavelength = 485 nm, Emission wavelength = 535 nm) and bioluminescence levels (RLU) readings were taken at regular periods over the course of the experiment as required.

## III. RESULTS AND DISCUSSION

To determine whether the extract had antimicrobial activity, bacteria were grown in the presence of liquorice extract at range of concentrations and it was found that 50 µg ml<sup>-1</sup> was sufficient to inhibit the growth of bacteria. For all further experiments two different concentrations were used (12.5 µg ml<sup>-1</sup> and 50 µg ml<sup>-1</sup>) and growth was monitored over time using optical density. In addition to these two test conditions, a control was prepared containing 1% (v/v) ethanol to rule out effects of the solvent used to prepare the liquorice extract. It was found that the extract only affected the growth of Gram-positive bacteria and at these concentrations all the Gram-negative bacteria tested showed normal levels of growth (see Fig. 2). For the Gram-positive bacteria, at 50 µg ml<sup>-1</sup> growth was completely inhibited, whereas at 12.5 µg ml<sup>-1</sup> growth rate was reduced but some growth was still detected (Fig. 2; panels C-E).

To determine if the effect of the liquorice extract on the Gram-positive organisms was bacteriocidal or bacteriostatic, *Listeria innocua* was chosen as a model organism being non-pathogenic and non-sporeforming. The experiment was repeated, this time monitoring both viable count and optical density. When 50 µg ml<sup>-1</sup> was used, it was found that although growth was totally inhibited, the number of viable cells did not decline over time indicating that the effect of the extract was bacteriostatic rather than bacteriocidal (Fig. 3).

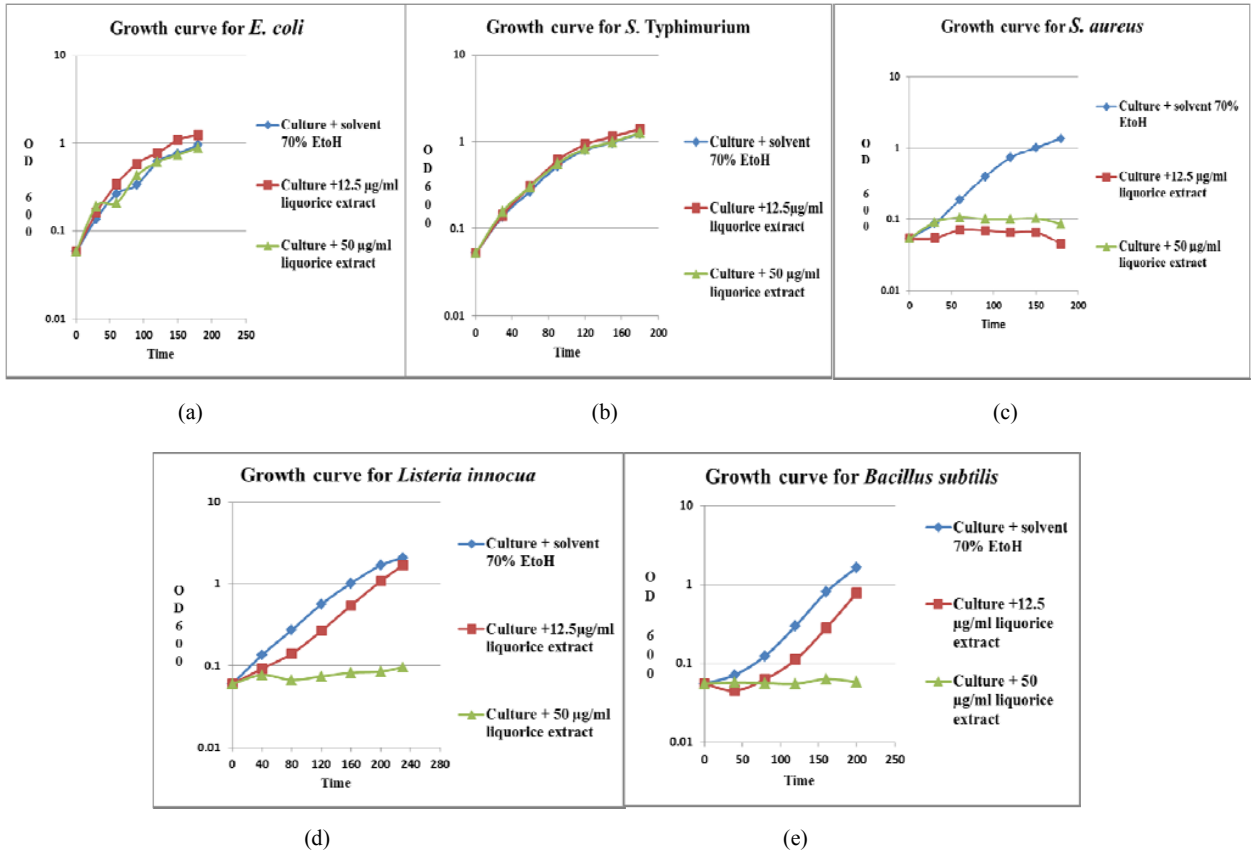

Fig. 2 The effect of liquorice extract on the growth of Gram-negative bacteria (a) & (b) and Gram-positive bacteria (c)-(e)

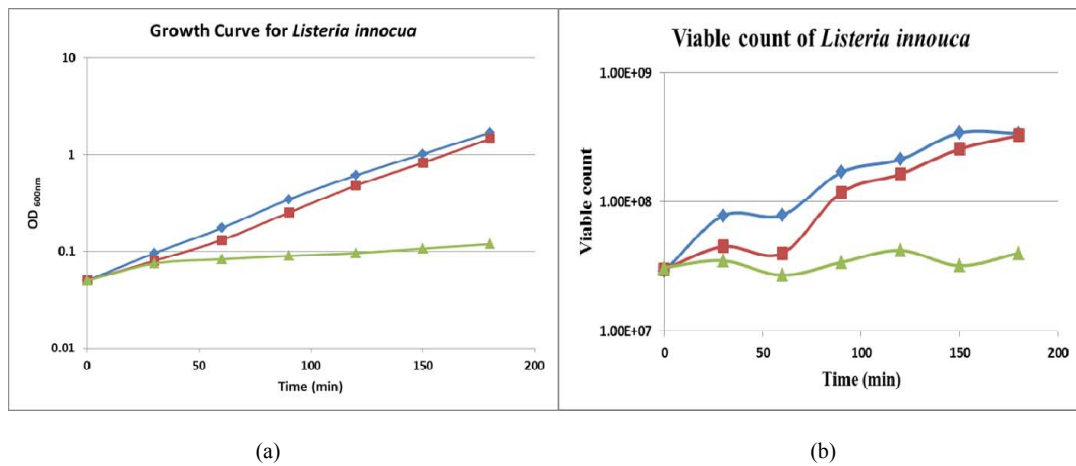
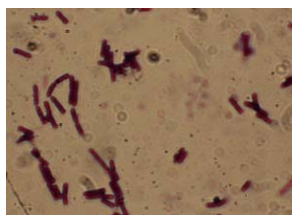

Fig. 3 The effect of liquorice extract on the growth (a) and the viable count (b) of *Listeria innocua*. Blue lines, 1% EtOH (control); Red lines, 12.5 µg ml<sup>-1</sup>; Green lines, 50 µg ml<sup>-1</sup>

As many of the bacteriostatic agents affect cell wall synthesis, experiments were carried out to monitor the cell morphology of *L. innocua* after the application of the liquorice was examined. Cultures were prepared as described above and then samples were taken at the beginning and the end of experiment, assessment of cell morphology using Gram-

staining of samples. It was found that samples treated with the liquorice extract were less able to take up the Crystal Violet stain and therefore appeared paler in colour and also the cell shapes were shorter and rounder than those seen in the control samples (Fig. 4), typical of agents that result in inhibition of cell division. Therefore, the results suggested that the primary

target of the liquorice extract is something common to the Gram-positive bacteria and may inhibit cell wall synthesis.



*L. innocua* Control (1% EtOH)

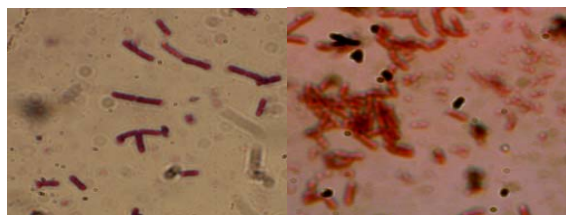

*L. innocua* 12.5 µg ml<sup>-1</sup>

*L. innocua* 50 µg ml<sup>-1</sup>

Fig. 4 Effect of extract on cell morphology

To try and further investigate the action of the liquorice extract, genetically engineered derivatives were used that contain the bacterial *lux* genes. However, these genes are encoded on plasmids and therefore to ensure that the cells all retain the plasmid, antibiotic selection is needed. In addition, we wanted to investigate whether any differences would be seen if different strains of the same bacteria were used. Hence the effect of strain variation was investigated by using different strains of *L. monocytogenes* in addition to *L. innocua*. Three wild type strains of *L. monocytogenes* were used, including serovars 1/2a and 4b which represent the major causes of human listeriosis (Table I). In addition, two mutant strains which either overexpress the virulence genes (NCTC 7973) or cannot express the virulence genes (NCTC 10537) were used. To carry out these experiments, different strains of bacteria (Table I) were grown in BHI broth supplemented with Erm (5 µg ml<sup>-1</sup>). These cultures were then diluted into fresh BHI + Erm to a standardized OD<sub>600nm</sub> of 0.05. To allow multiple samples to be monitored, and to allow simultaneous measurement of OD and light, cultures were transferred into a microtiter plate and incubated at 37 °C over a 24 h period. Due to the possibility of contamination using a microplate reader an uninoculated control sample was included (purple line, Fig 5) to show that any change in optical density or light was due to the organism inoculated into the broth.

The results gained using the microtitre plate showed the same pattern as before, in that a concentration of 50 µg ml<sup>-1</sup> totally inhibited growth, but at 12.5 µg ml<sup>-1</sup> very little inhibition of growth was seen (Fig. 5).

The pattern of results gained was exactly the same for all strains and species of *Listeria* tested, showing that this was a very reproducible effect. However, when the levels of light produced from each of the strains was examined (Fig. 6) it was clear that even when growth was not affected, a reduction

is the light output could be seen, although this was more pronounced in some strains than others. This result indicated that the cells were experiencing some stress at the sub-lethal injury level as the level of light is representative of the overall metabolic state of the cells. It was also noted that the metabolic level of the strains challenged with 50 µg ml<sup>-1</sup> were very similar to the background control, suggesting that in addition to effects on cell division, the cell membrane may be affected.

Since there were now both variations in growth rate and light output recorded it was important to normalize the bioluminescence data according to the number of cells in the sample (i.e. 10 cells producing 1 unit of light would give the same signal as 1 cell producing 10 units of light). To address this, the bioluminescence data was divided by the optical density data and the results are presented in Fig. 7. This treatment of the data clearly revealed that the cells treated with 12.5 µg ml<sup>-1</sup> were experiencing sub-lethal injury resulting in overall lower levels of metabolic activity. Since cell division was not affected in these cells as the growth rate was close to that of the control, this suggests that at sub-lethal levels the liquorice extract may be affecting either cell membrane integrity or other enzymes required for the production of FMNH<sub>2</sub> within the cells.

One question that remained was whether the presence of the antibiotic required for the selection of the plasmids was providing an additional stress on the cells that accounted for the results seen in the last experiment. To determine whether the presence of the antibiotic was required to maintain the *lux* plasmids inside the cells, the stability of the plasmid was determined by growing *L. monocytogenes* 10403S containing the plasmid in the presence and absence of the selective antibiotic (Erm 5µg ml<sup>-1</sup>), and rates of plasmid-loss were calculated (Tables III & IV). These experiments were also performed with and without the additional stress caused by the presence of the liquorice extract. The stability of the plasmid was determined by comparing the viable count of samples taken from the experiment and plating on agar with and without Erm and is expressed as the 100% of cells (viable count on BHI) retaining the plasmid (viable count on BHI Erm).

When grown in the absence of the antibiotic, the rates of plasmid loss were very low (92-80%; Table III) indicating that the plasmids themselves were very stable, but that plasmid stability varied with the concentration of the liquorice extract, suggesting that it was exerting a metabolic stress on the cells. In the presence of the antibiotic in the growth medium, the plasmid was more stable (as expected) but even then plasmid loss was seen when the cells were grown in the presence of the liquorice extract (93-97%; Table IV). This result validated the data shown in Fig. 7, since it is clear that the addition of the antibiotic alone is not causing a major stress on the bacterial cells.

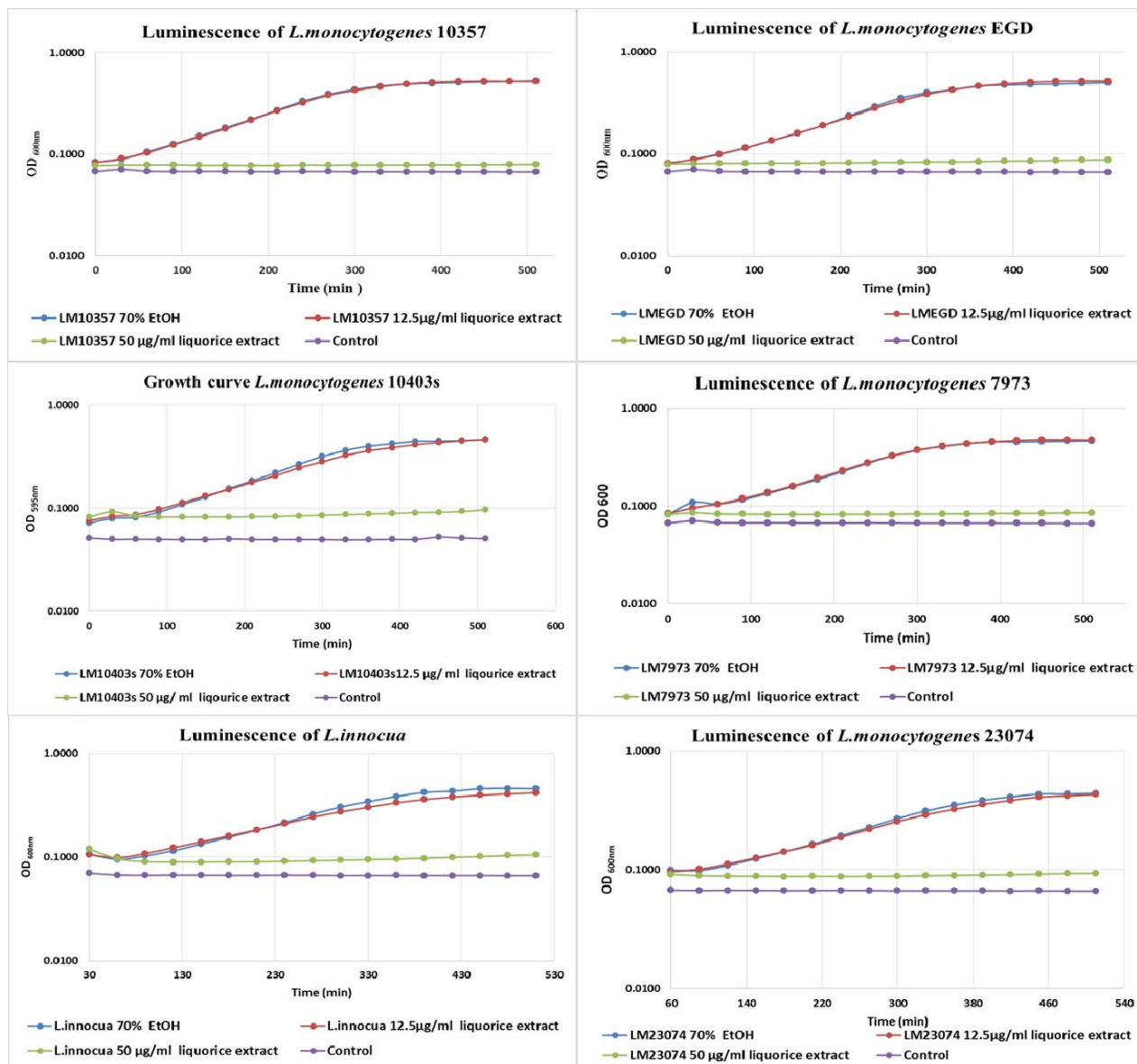

Fig. 5 Growth curve of six strains of *Listeria monocytogenes*

TABLE III  
PLASMID STABILITY IN LM10403S WITHOUT SELECTION

LM 10403s (BS10, <i>luxABCDE</i> , <i>gfp</i> ) without Erm in the Growth Media	BHI Agar with 5 µg ml <sup>-1</sup> Erm = Plasmid Present in Cell (cfu ml <sup>-1</sup> )	BHI Agar without Erm = viable count (cfu ml <sup>-1</sup> )	% Bacteria with Plasmid
EtOH Control	2.7x10 <sup>9</sup>	3.2x10 <sup>9</sup>	92%
12.5 µg/ml liquorice extract	2.54x10 <sup>9</sup>	3.06x10 <sup>9</sup>	82%
50 µg/ml liquorice extract	1x10 <sup>6</sup>	1x10 <sup>6</sup>	80%

TABLE IV  
PLASMID STABILITY IN LM10403S WITH SELECTION (ERM)

LM 10403s (BS10, <i>luxABCDE</i> , <i>gfp</i> ) with 5 µg ml <sup>-1</sup> Erm in the Growth Media	BHI Agar with 5 µg ml <sup>-1</sup> Erm = Plasmid Present in Cell (cfu ml <sup>-1</sup> )	BHI Agar without Erm = viable count (cfu ml <sup>-1</sup> )	% Bacteria with Plasmid
EtOH Control	1.43x10 <sup>10</sup>	1.34x10 <sup>10</sup>	100%
12.5 µg/ml liquorice extract	2.64x10 <sup>10</sup>	2.83x10 <sup>10</sup>	93%
50 µg/ml liquorice extract	9.7x10 <sup>7</sup>	9.9x10 <sup>7</sup>	97%

\*Erm: erythromycin

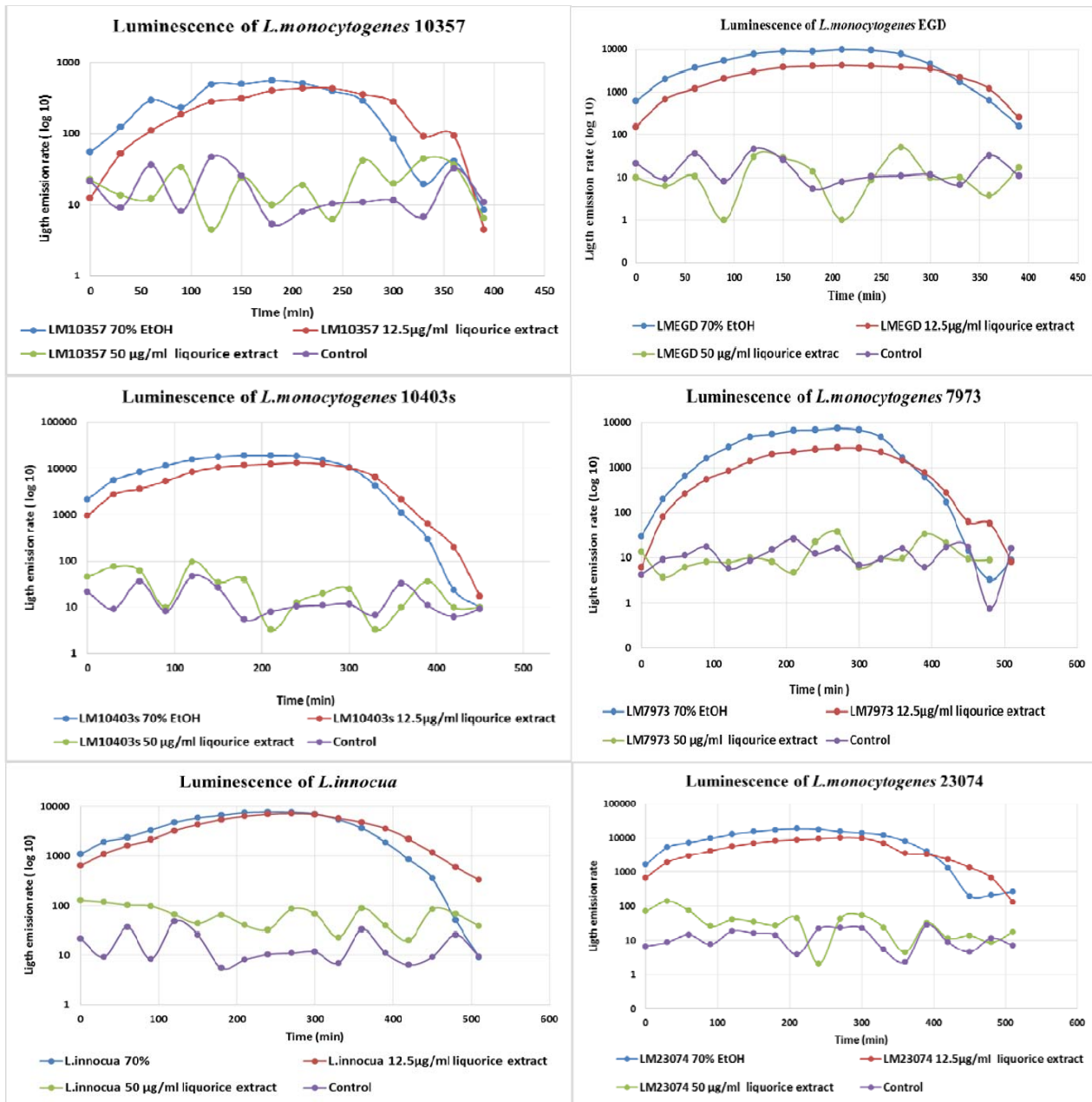
Fig. 6 Effect of liquorice extract on light emitted by *Listeria* strains

#### IV. CONCLUSION

In conclusion, the results of this work show that Gram-positive bacteria are more susceptible to the liquorice extract than Gram-negative bacteria. A range of different cell types were tested (Gram-positive rods, Gram positive cocci and spore forming organisms) and all showed equal sensitivity suggesting there is a common target in all these different types of Gram-positive bacteria. Using *L. monocytogenes* strains and *L. innocua* as model organisms, the nature of the growth inhibition seen was further investigated and it was clear that cell growth, including cell division, was affected. At sub-lethal

concentrations, even when growth rate was not particularly affected, there was evidence of sub-lethal injury and cell stress.

In this study, we have used bioluminescence to quickly evaluate the effect of an antimicrobial on bacterial metabolism. This approach has been used before by many workers but some caution must be taken to ensure that the results gained are not simply due to the presence of the plasmid in the strains. In this case we found that the stress caused by treating the bacteria with the liquorice extract did exert some additional metabolic pressure on the cells, leading

to plasmid loss unless antibiotic was added to the media but there was no evidence of a significant difference in results gained with and without antibiotic.

Another area of caution is that strains of bacteria such as *Listeria* that have been cultured for long periods of time in the laboratory may have lost some of their fitness. To address this, we tested a range of different isolates, including examples of the two serovars that are responsible for the majority of human infections. Again no different was seen between the sensitivity of different strains indicating that the results gained were very reproducible and not dependent on the test strain used. In

addition, we tested two well characterised mutants of *L. monocytogenes*, one which over expressed the virulence genes (NCTC 7973 *prfA*\*) and another than is incapable of expressing the virulence genes due to a deletion of the virulence gene regulator (NCTC 10357;  $\Delta prfA$ ). The results gained with these strains were also identical the results gained with wildtype *L. monocytogenes* and *L. innocua*, which has a complete absence of any of the virulence genes found in *Listeria*. Again these results suggest that the target site is found in all cell types and is not associated with the virulence traits of these bacteria.

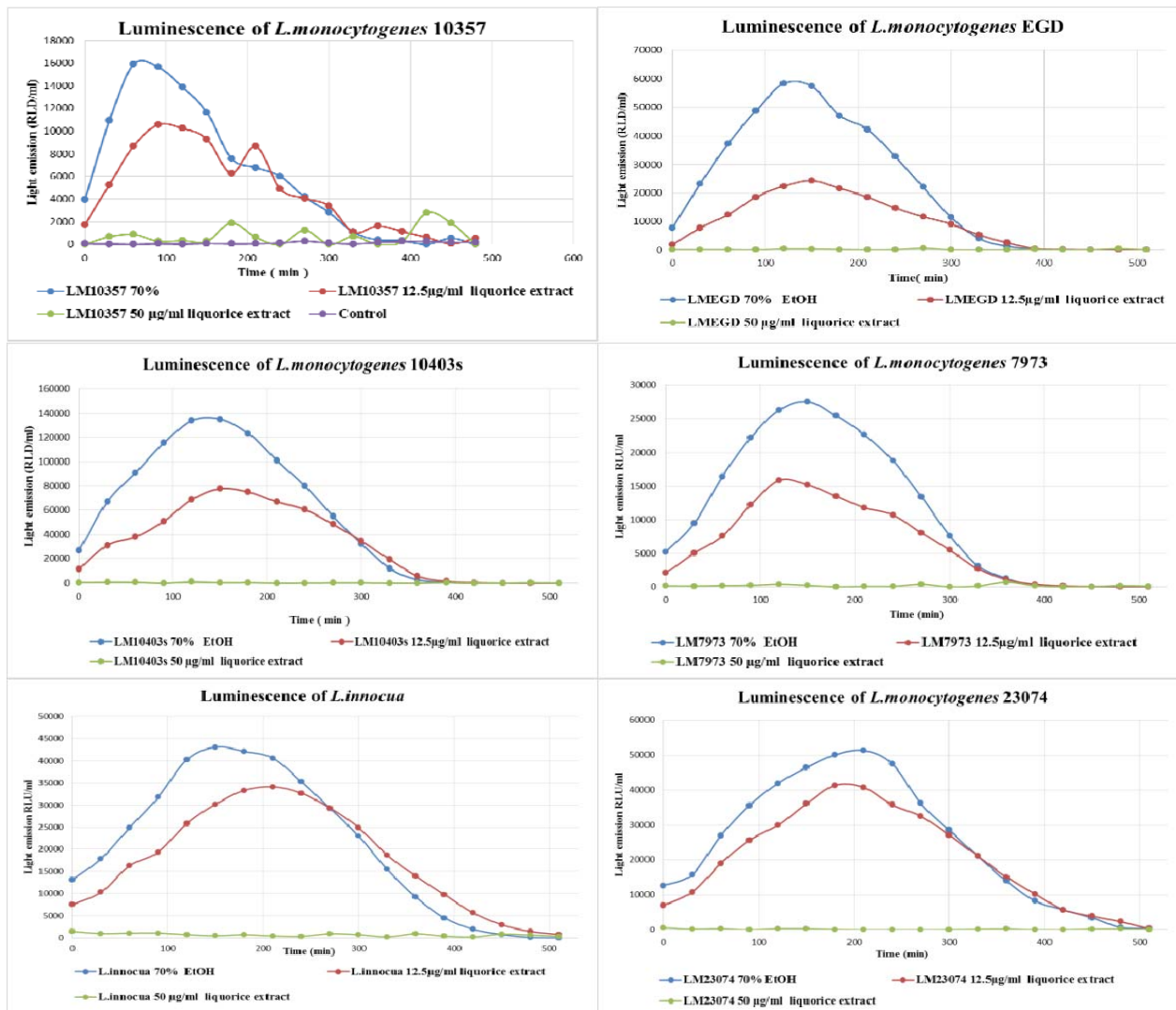

Fig. 7 Effect of liquorice extract on light emitted by *Listeria* strains, light emission was normalized by dividing RLU/OD

Treatment with 50 µg ml<sup>-1</sup> of liquorice extract completely inhibited the growth of all of the Gram-positive bacteria tested, but when plated on to media without the extract they were able to grow normally indicating that stress is bacteriostatic rather than bactericidal. It is interesting to note that without the use of the bioluminescent reporter genes, the

separate effect on cell metabolism would not have been evident and therefore this shows that using these tools is a powerful way to better identify stresses that have an effect on metabolic activity through damaging the membrane integrity or affecting enzymes associated with energy generation.



Since this extract was produced as a waste product from the food industry, there is the potential that it could be applied as a novel food preservative. The extract was active at 50 µg ml<sup>-1</sup> and this is a level that could be used for such a practical application. However, more work would be required to establish whether there would be any organoleptic changes to the foods if used at this level. Another area of interest is if it could be used to inhibit the growth of *Clostridium difficile* in the human gut in patients suffering with hospital acquired infections. This difficult to treat Gram-positive bacterium causes a major problem, particularly in patients recovering from extensive antibiotic therapy. A formulation of this extract given as a drink could help target these bacteria and allow normal gut flora to re-establish without the need for further extensive antibiotic therapy.

## REFERENCES

- [1] Organization, W. H. WHO estimates of the global burden of foodborne diseases: foodborne disease burden epidemiology reference group 2007–2015 (cited 2016 Feb 8).
- [2] WTO. International trade statistics 2015. Geneva: World Trade Organization.
- [3] WHO. Food safety & food-borne illness. Fact sheet no. 237 (reviewed March 2007). Geneva: World Health Organization; 2007a.
- [4] WHO. The world health report, 2007. Global public health security in the 21st century. Geneva: World Health Organization; 2007b.
- [5] Farber, J., Coates, F. & Daley, E. 1992. Minimum water activity requirements for the growth of *Listeria monocytogenes*. *Letters in Applied Microbiology*, 15, 103-105.
- [6] McLinden, T., Sargeant, J. M., Thomas, M. K., Papadopoulos, A. & Fazil, A. 2014. Component costs of foodborne illness: a scoping review. *BMC Public Health*, 14, 1.
- [7] Alocilja, E. C. & Radke, S. M. 2003. Market analysis of biosensors for food safety. *Biosensors and Bioelectronics*, 18, 841-846.
- [8] Chemburu, S., Wilkins, E. & Abdel-Hamid, I. 2005. Detection of pathogenic bacteria in food samples using highly-dispersed carbon particles. *Biosensors and Bioelectronics*, 21, 491-499.
- [9] Thomas, M. K., Vriezen, R., Farber, J. M., Currie, A., Schlech, W. & Fazil, A. 2015. Economic cost of a *Listeria monocytogenes* outbreak in Canada, 2008. *Foodborne Pathogens and Disease*, 12, 966-971.
- [10] Olszewska, M. A., Panfil-Kuncewicz, H. & Łaniewska-Trokenheim, Ł. 2015. Detection of Viable but Non-culturable cells of *Listeria monocytogenes* with the use of direct epifluorescent filter technique. *Journal of Food Safety*, 35, 86-90.
- [11] RAGHU, R. 2013. *Listeria monocytogenes*: An interesting pathogen. *Microbiology Focus* 5, 1–2.
- [12] Montañez-Izquierdo, V. Y., Salas-Vázquez, D. I. & Rodríguez-Jerez, J. J. 2012. Use of epifluorescence microscopy to assess the effectiveness of phage P100 in controlling *Listeria monocytogenes* biofilms on stainless steel surfaces. *Food Control*, 23, 470-477.
- [13] Vazquez-Boland, J. A., Kuhn, M., Berche, P., Chakraborty, T., Dominguez-Bernal, G., Goebel, W., et al. (2001). *Listeria* pathogenesis and molecular virulence determinants. *Clinical Microbiology Reviews*, 14(3), 584e640.
- [14] Nocker, A., Caspers, M., Esveld-Amanatidou, A., Van der Vossen, J., Schuren, F., Montijn, R. & Kort, R. 2011. A multiparameter viability assay for stress profiling applied to the food pathogen *Listeria monocytogenes* F2365. *Applied and Environmental Microbiology*, 77, 6433-40.
- [15] Hill, P. J. & Stewart, G. S. 1994. Use of *lux* genes in applied biochemistry. *Journal of Bioluminescence and Chemiluminescence*, 9, 211-215.
- [16] Meighen, E. 1993. Bacterial bioluminescence: organization, regulation, and application of the *lux* genes. *The FASEB Journal*, 7, 1016-1022.
- [17] Pehinec, T. M., Qazi, S. N., Gaddipati, S. R., Salisbury, V., Rees, C. E. & Hill, P. J. 2007. Construction and evaluation of multisite recombinatorial (Gateway) cloning vectors for Gram-positive bacteria. *BMC Molecular Biology*, 8, 1.
- [18] Robinson, G. M., Tonks, K. M., Thorn, R. M. & Reynolds, D. M. 2011. Application of bacterial bioluminescence to assess the efficacy of fast-acting biocides. *Antimicrobial Agents and Chemotherapy*, 55, 5214-5219.
- [19] Lorang, J., Tuori, R., Martinez, J., Sawyer, T., Redman, R., Rollins, J., Wolpert, T., Johnson, K., Rodriguez, R. & Dickman, M. 2001. Green fluorescent protein is lighting up fungal biology. *Applied and Environmental Microbiology*, 67, 1987-1994.
- [20] Zimmer, M. 2002. Green fluorescent protein (GFP): applications, structure, and related photophysical behavior. *Chemical reviews*, 102, 759-782.
- [21] Lowder, M., Unge, A., Maraha, N., Jansson, J. K., Swiggett, J. & Oliver, J. D. 2000. Effect of Starvation and the Viable-but-Nonculturable State on Green Fluorescent Protein (GFP) Fluorescence in GFP-Tagged *Pseudomonas fluorescens* A506. *Applied and Environmental Microbiology*, 66, 3160-3165.
- [22] Qazi, S., Rees, C., Mellits, K. & Hill, P. 2001. Development of gfp vectors for expression in *Listeria monocytogenes* and other low G+C Gram-positive bacteria. *Microbial Ecology*, 41, 301-309.
- [23] Qazi, S. N., Counil, E., Morrissey, J., Rees, C. E., Cockayne, A., Winzer, K., Chan, W. C., Williams, P. & Hill, P. J. 2001. *agr* expression precedes escape of internalized *Staphylococcus aureus* from the host endosome. *Infection and Immunity*, 69, 7074-7082.