

# Hospital Based Electrocardiogram Sensor Grid

Suken Nayak, Aditya Kambli, Bharati Ingale and Gauri Shukla

**Abstract**—The technological concepts such as wireless hospital and portable cardiac telemetry system require the development of physiological signal acquisition devices to be easily integrated into the hospital database. In this paper we present the low cost, portable wireless ECG acquisition hardware that transmits ECG signals to a dedicated computer. The front end of the system obtains and processes incoming signals, which are then transmitted via a microcontroller and wireless Bluetooth module. A monitoring purpose Bluetooth based end user application integrated with patient database management module is developed for the computers. The system will act as a continuous event recorder, which can be used to follow up patients who have been resuscitated from cardiac arrest, ventricular tachycardia but also for diagnostic purposes for patients with arrhythmia symptoms. In addition, cardiac information can be saved into the patient's database of the hospital.

**Keywords**—ECG, Bluetooth communication, monitoring application, patient database

## I. INTRODUCTION

ELECTROCARDIOGRAPHIC (ECG) monitoring is been carried out in hospital units for more than 40 years [1]. The methods of monitoring have expanded from simple plotting of heart rhythm in graph paper to the use of software algorithms for diagnosis of complex arrhythmias. During the same 4 decades, major improvements have occurred in cardiac monitoring systems including ischemia monitoring software, improved noise-reduction electronic circuits, multilead monitoring, and reduced lead sets for monitoring-derived 12-lead ECG with a minimal number of electrodes. In hospitals, continuous ECG monitoring is indicated for patients, who have been resuscitated from cardiac arrest, adults who have undergone cardiac surgery, patients with associated ventricular arrhythmia and for also those who are at low risk of cardiac arrhythmia. For the management of various departments in the hospital it can be very important to monitor for long periods for timely treatment of cardiac patients. It is possible to monitor patients that can help to regulate therapies and treatment.

Suken Nayak is with Department of Biomedical Engineering, Thadomal Shahani Engineering College, Mumbai-400101. email id: nayak\_suken@yahoo.com

Aditya Kambli is with Department of Biomedical Engineering, Thadomal Shahani Engineering College, Mumbai-400101. email id: aditya.kambli@ymail.com

Bharati Ingale is Professor, Department of Biomedical Engineering, Thadomal Shahani Engineering College, Mumbai-400101. email id: bharati\_ingale@yahoo.com

Gauri Shukla is Professor, Department of Biomedical Engineering, Thadomal Shahani Engineering College, Mumbai-400101. email id: gaurimshukla@gmail.com

Wireless sensor networks are increasingly adopted in clinical applications due to several reasons: the need of continuous monitoring, their link to hospital area networks and the use of digital computers and PDAs (Personal Digital Assistant) as clinical data terminals.

Most of wireless monitoring systems designed so far have processing unit that samples the physiological data, stores it for short duration and then transmit it to the doctor's end [2],[3]. That is they are available only for observation and the monitoring application does not save the data for further treatment procedures. Holter monitoring had been introduced with great advantage but unfortunately, diagnostic yields are very low (5-13%) [6]. Hence we propose a novel design yielding a solution for the set of requirements mentioned above. It is capable of providing different operation ways (alarm, data saving), continuous signal processing (detecting heart rate), and interoperability (computer) and low-power consumption. Furthermore, the technology has the potential to reduce human error, decrease time to diagnosis and improve patient care. Thus from a diagnostic viewpoint, the technology can be useful in patients experiencing frequent cardiac symptoms.

Some wireless communications such as GSM/GPRS, Bluetooth, ZigBee, WLAN IEEE 802.11 can be used to transmit ECG signal. The chosen wireless system is Bluetooth. ECG transmission based on Bluetooth protocol enables free movement of the patient thus minimizing motion error. In particular, Bluetooth standard offers important advantages: low cost, share voice and data, low interferences, low power consumption, confidentiality of the data, size of the device, upgradeable and it is capable of generating small pionet of communicating devices [8]. Also it is embedded in most of portable, computers and mobile phones. Thus, data collected in computer can be integrated with the doctor's module of patient data management system of the hospital.

## II. SYSTEM DESCRIPTION

Figure 1 shows the overview of real time ECG monitoring system using remote computer. The system comprises of two main parts: the hardware system (ECG acquisition and wireless transmission module) and the ECG monitoring application for computers. The ECG acquisition system comprises of bio-amplifier and the band pass filter. The signal processing and wireless transmission is carried out by the microcontroller and the Bluetooth module respectively. The ECG monitoring application in the computer displays the signal and calculates average heart rate. The block diagram of the entire system is shown below:

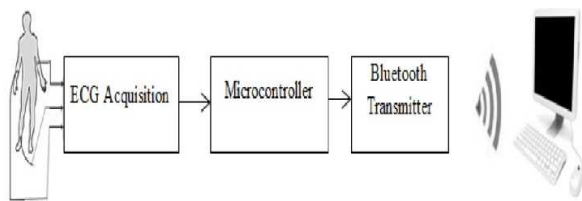

Fig.1 System Block Diagram

The ECG signals are picked up from the body with Ag/AgCl disposable pregelled electrodes in which the metal electrode does not make direct contact with the skin. The contact impedance shown by these electrodes varies from 20 K $\Omega$  in 50 Hz and 100 Hz to 75 K $\Omega$  in 1 Hz[4].

It is connected to the amplifier board with press stud cable whose shield is grounded. This is mainly done to reduce noise interference. The preamplifier is an instrumentation amplifier with very high CMRR and high gain variability.

After amplification it is filtered by the second order Butterworth filter (Band pass filter) with the lower cut-off frequency of 0.5Hz and higher cut-off frequency of 100Hz. The noise free signal is amplified by an output amplifier with a very high gain.

The ECG signal is then given to the microcontroller with an inbuilt 10 bit ADC (Analog to Digital Converter) which converts the analog ECG signal into digital data. The binary data is transmitted through a Bluetooth master module. The Bluetooth module transmits the data through a generic UART layer of Host Controller Interface (HCI) [9]. The Serial Port Profile (SPP) defines the requirements for Bluetooth devices necessary for setting up emulated serial cable connections using RFCOMM protocol between two communicating devices.

These signals are received by a Bluetooth enabled computer. The binary data reception through Bluetooth virtual COM port is initialized by end-user application. Visual Basic is used to create .NET Framework based Windows application. The application was built by acquiring some necessary Bluetooth API's (Application Programming Interface).

The viewer application helps to plot a real time ECG signal. This ECG monitoring application is integrated with the patient data management system. The user can observe and save ECG waveform for probable further analysis by the consulting doctor or by other departments of the hospital.

### III. SYSTEM DESIGN

In the former section, we described the basic architecture of the hardware and the software system. The overall goal is to have viable cardiac signals processed on the microcontroller and then sent to a remote computer to be further aggregated and store in the remote database management infrastructure. Based on the functionality of each section, we have divided it into four major parts: ECG Acquisition, ECG Signal Processing, Bluetooth Data Transmission and ECG monitoring in Patient Data Management System (PDMS) module.

#### A. ECG Acquisition

In our acquisition system, we have used a simple 3-lead system. The developed ECG circuitry has all the good properties such as robustness, low power consumption, portable as well as those required for telemedicine application. The ECG electrodes continuously tap the ECG signal from the patient's body having specifications of low differential voltage from 1 to 3 mV, high common-mode rejection ratio level and low frequency range. The bio-amplifier has been implemented by using AD620 which is low voltage, high precision, high input impedance instrumentation amplifier [10]. The bio-amplifier is shown in Fig.2. A right leg driver circuit is used which reduces common-mode noise. Common-mode signals are "bootstrapped" to ground through the right leg drive amplifier. The resulting common-mode rejection ratio improves significantly since electrodes do not reduce skin impedance. The instrumentation amplifier serves as a preamplifier with a gain of 10. This pre-amplified signal is fed to a high pass filter with a cut off frequency of 0.5Hz. It is then followed by a low pass filter with a cut off frequency of 100Hz. The signal is then fed to an output amplifier whose gain is set to 100.

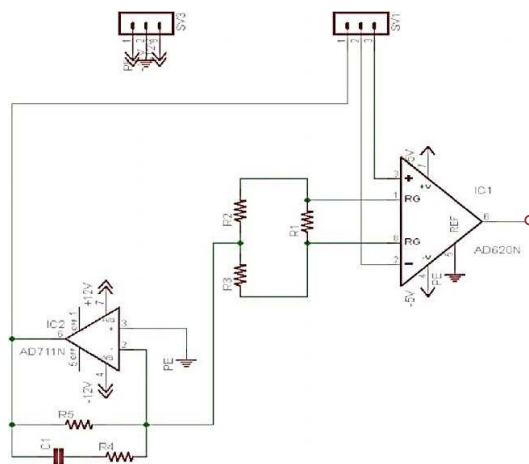

Fig. 2 Bio-Amplifier

The filtering stage is a band pass filter to eliminate the artifacts caused by muscle contractions, respirations, movement of the electrode cables, and by other electronic equipment's or radio interferences.

#### B. ECG Signal Processing

There are many microcontrollers and DSP's (Digital Signal Processors) used for signal processing of various physiological signals. An ATMEGA32A microcontroller is used for the design which area able to acquire and process the signals for monitoring application [11]. This device is a low power, 8-bit microcontroller based on advanced RISC architecture with inbuilt 8 channel 10 bit Analog to Digital Converter. The amplified and filtered ECG signal was given to a DC shifting circuit before A to D conversion because the microcontroller itself does not operate on negative voltage range. We have selected a 500Hz sampling frequency, with a resolution of 10 bits.

It achieves throughputs approaching 1 MIPS per MHz allowing us to optimize power consumption versus processing speed. In the system design, the speed of computation and memory capacity are considered as the two most important characteristics. Since the ATMEGA32A device has these properties, it has been chosen for our design. The digitized data is transmitted to Bluetooth module through UART ports.

### C. Bluetooth Data Transmission

Among short range wireless networks such as RFID, Bluetooth and IR, the most feasible one is Bluetooth technology as it has the essential ingredients whether it is the data rate or the error rate at which it transmits. Also studies indicate that Bluetooth technology is electro magnetically compatible with the tested medical devices [5]. Hence we propose to use Bluetooth link between the wireless ECG transmitter and the receiving computer. Bluetooth (IEEE 802.15) is a universal short range low-power radio protocol operating in the unlicensed industrial, scientific and medical frequency band. It allows both data and voice transmission. The modulation technique is GFSK (Gaussian Frequency Shift Keying), with transmission at a rate of 1M symbols/s on one of 79 channels with 1MHz spacing in the 2.402GHz-2.480 GHz band [7]. Bluetooth uses the spread-spectrum frequency hopping connection with a rate of 1600 hops/s. Compared to other methods of transmission; Bluetooth facilitates a noise free transmission. Moreover privacy and security options are highly advanced in the case of Bluetooth.

The Bluetooth module used is the WT11i chip from Bluegiga [12]. It provides an API for communication through the AT commands. This chip requires a regulated power supply of 3.3V for its operation. It is a class 1 model that has an approximate range of 100 meters and an internal antenna or 50Ω RF pin.



Fig. 3 WT11i Bluetooth Transceiver chip

This transceiver chip serves both as a transmitter and a receiver. However, the mode of communication between the wireless transmitter and the computer is of the type simplex. Hence, the job of the Bluetooth transceiver situated in the wireless ECG transmitter is only to transmit. The Bluetooth transmitter is configured as master and the computer's Bluetooth is considered to be functioning as a slave. The signal acquisition unit sends data to the Bluetooth module through serial port, which transmits data continuously as blocks of ECG samples. The data are sent as raw binary bytes. The transmitter starts with base band GFSK modulation data, which passes through a Gaussian filter. GFSK is a modulation technique where the data change the frequency of the carrier linearly for some amount of a carrier cycle during the duration of a bit.

The rate of frequency change is a function of the data rate. The amount of the frequency change is a function of the amplitude of the data.

### D. ECG Monitoring in PDMS module.

Visual Basic 10 was used to create a .NET application for ECG monitoring. Wireless Communication Library (WCL) [13],[14] API for Bluetooth framework was acquired for establishing wireless communication between Bluetooth transmitter and computer. It includes full components and classes set that allows to enumerate and to manage local Bluetooth radios, to inquire remote Bluetooth enabled devices, to discover its services, to send and receive the data. The front end of the ECG monitoring application reads the data from the serial port and plots waveform.

The VB.net method [15] reads the binary data and displays ECG waveform on the user interface. Received data is converted into ASCII and plotted with respect to reference point. The R peak is determined for the ECG cycle and average heart rate is calculated and displayed on the screen. It also triggers alarm if heart rate (bpm) falls outside the normal range.

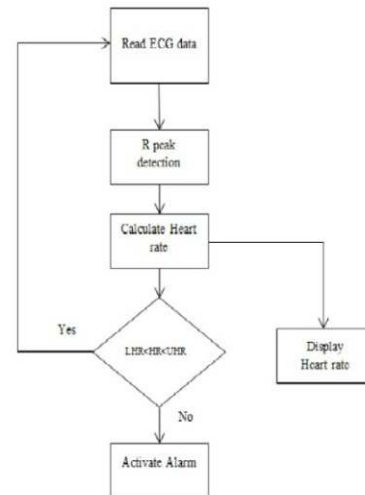

Fig. 4 Signal processing and alarm activation block diagram

Vb.net method also provides different methods to save the graphical data. Thus, plotted ECG signal is saved into hospital's database using patient data management system (PDMS). This is done by converting the graphical data of the ECG signal into an image file. The compatible file of the ECG signal can be saved into the respective patient database using patient unique ID. If the ECG signal of a particular patient has to be viewed at a later stage for clinical analysis, it can be retrieved by using the patient's unique ID.

## IV. RESULT

The complete wireless ECG monitoring system has been tested for acquiring and transmitting the ECG signal to the computer. ECG acquisition and signal processing modules were implemented in a small single layer PCB (Printed Circuit Board).

The designed acquisition system was able to successfully transmit the ECG signals through Bluetooth module. For test purpose, HyperTerminal software was used to check serial data communication between Bluetooth transmitter and the computer. An ECG simulator was used to test tachycardia and bradycardia conditions and simultaneously output was observed by varying heart rate. The ECG waveform displayed on the doctor's module of patient data management system was saved directly into the patient's database of the hospital as an image file. The sample image of the patient saved into the back-end shared database can be accessed by other departments of the hospital.

- [11] <http://www.atmel.com/Images/doc8155.pdf>
- [12] <http://www.bluegiga.com/>
- [13] <http://msdn.microsoft.com/enus/library/w0x726c2.aspx>
- [14] <http://www.btframework.com/wcl.htm>
- [15] <http://msdn.microsoft.com/en-us/library/dd489233.aspx>

## V. CONCLUSION

We have designed a low cost, portable ECG acquisition system which continuously monitors cardiac patients and provides visualization in computer. It provides flexibility by storing patient's ECG data in hospital's database using patient data management system (PDMS).

The wireless ECG monitoring system is battery operated system which makes it a portable device. Monitoring cardiac patients or patients suffering from arrhythmias in the hospital with such device provides complete ECG analysis and improves patient care. Thus, integrating cardiac monitoring application to hospital's database obviates conventional ECG paper outputs. As a future enhancement, we recommend monitoring systems of other biological signals such as EEG (Electroencephalograph), EMG (Electromyography), blood pressure, body temperature and pulse-oximeter to be connected to the Patient Data Management System using Bluetooth technology. Although there is no interference of Bluetooth with monitoring devices, it should be introduced with care in a hospital. Appropriate protocols are necessary while using Bluetooth-based monitoring system. The protocol must be designed to ensure data integrity. GSM/GPRS or WIFI technologies can also be used to connect hardware processing system to the hospital's database.

## REFERENCES

- [1] Day HW. Preliminary studies of an acute coronary care Area Lancet.1963; 83: 53-55.
- [2] B.Woodward, R.S.H.Istepanain and C.I.Richards, "Design Of Tele medicine system using a mobile Telephone," IEEE Trans inf.Tech in Biomedicine, vol.5, no.1, march 2001, pp 13-15.
- [3] Mohd Fadlee A. Rasid and Bryan Woodwar "Bluetooth telemedicine processor for multichannel biomedical signal transmission via mobile cellular networks," IEEE Trans. Inf .Tech in Biomedicine, vol .9, no.1, 2005 pp.35-43.
- [4] Zepeda-Carapia, Marquez-Espinoza, A. Alvarado-Serrano, "Measurement of skin-electrode impedance for a 12-lead Electro cardiogram", 2nd International Conference Electrical and Electronics Engineering, 2005, pp 193-195.
- [5] Mats K. E. B. Walling MD, MSc t, and Samson Wajntraub, MSct, "Evaluation of Bluetooth as a Replacement for Cables in Intensive Care and Surgery," Critical Care and Trauma, Technical Communication, September 8, 2003.
- [6] Dina Simunic, Slaven Tomac, Ivan Vrdoljak, "Wireless ECG Monitoring System" ,Wireless VITAE 2009, pp 73-76.
- [7] Nathan. J. Muller, Bluetooth Demystified. McGraw Hall Edition, 2000.
- [8] <http://www.bluetooth.org>
- [9] <http://www.dziwior.org/Bluetooth/HCI.html>
- [10] [http://www.analog.com/static/imported-files/data\\_sheets/AD620.pdf](http://www.analog.com/static/imported-files/data_sheets/AD620.pdf)