

High-Speed Pipeline Implementation of Radix-2 DIF Algorithm

Christos Meletis, Paul Bougas, George Economakos, Paraskevas Kalivas and Kiamal Pekmestzi

Abstract— In this paper, we propose a new architecture for the implementation of the N-point Fast Fourier Transform (FFT), based on the Radix-2 Decimation in Frequency algorithm. This architecture is based on a pipeline circuit that can process a stream of samples and produce two FFT transform samples every clock cycle. Compared to existing implementations the architecture proposed achieves double processing speed using the same circuit complexity.

Keywords—Digital signal processing, systolic circuits, FFT algorithm.

I. INTRODUCTION

MODERN telecommunication systems are based more than ever before on digital signal processing. High-speed digital telecommunication systems such as OFDM (Orthogonal Frequency Division Multiplexing) and DSL (Digital Subscriber Lines) need real-time high-speed computation of the Fast Fourier Transform.

Many different hardware architectures have been proposed for the implementation of FFT algorithms [1-8]. A first approach for these implementations concerns time non-critical applications and has small hardware requirements, but it needs a significantly large number of clock cycles to compute a full FFT. For example, in [1] one butterfly unit is used for all computations and $N+N\log_2N$ clock cycles are required for the computation of the FFT. A second implementation approach is for speed demanding applications, where one butterfly unit is used for each decimation stage of a radix-2 FFT. A pipeline architecture based on the constant geometry radix-2 FFT algorithm, which uses \log_2N complex-number multipliers (more precisely butterfly units) and is capable of computing a full N-point FFT in $N/2$ clock cycles has been proposed by J. Choi and V. Boriakoff [2]. However, this architecture requires a large amount of delay elements (memory size of $N\log_2N$ samples) and a quite complicated switching mechanism for the routing of the data. Another

architecture proposed by V. Boriakoff [3] uses three times more complex-number multipliers ($3N\log_2N$) but has less delay elements ($2N+5\log_2N+2$), a simple control circuit and can compute a full N-point FFT in N clock cycles. Also C. Chang, C. Wang and Y. Chang [1] have proposed an implementation that uses \log_2N complex multipliers and $N+\log_2N-1$ delay elements in order to compute the N-point FFT in N clock cycles. However, this implementation can be further improved, considered that the complex-number multipliers are utilized only for the 50% of the operation time.

In this paper we propose an architecture that permits 100% hardware utilization and can compute the N-point FFT in $N/2$ clock cycles, using $N\log_2N$ complex multipliers, $2N\log_2N$ complex adders and $N+2\log_2N-2$ delay elements.

II. ARCHITECTURE FOR RADIX-2 DECIMATION IN FREQUENCY FFT REVIEW STAGE

The $N/2$ butterfly operations included in every stage can be performed, sequentially, by the same Butterfly Unit. Because the two inputs of a Butterfly Unit of a stage are generated from the output of the Butterfly Unit of the previous stage at different time points, and the two inputs of a Butterfly Unit of a stage are obtained from either the upper or the lower output of the Butterfly Unit of the previous stage, a Shuffling Unit is inserted between two successive Butterfly Units in order to route these outputs to the corresponding inputs.

The block diagram of the implementation proposed for the N-point DIF FFT, where N is a power of two, is shown in Fig. 1. This circuit is an expansion of the circuit of Fig. 4, since additional are added in order to implement the additional stages of the FFT. The circuit consists of the FFT Processor, which performs the operations needed for the computation of the FFT (Butterfly and Shuffling Units) and two adaptation units; the Input Adaptation Unit, which converts the input stream of samples to two separate ones in order to provide the inputs of the FFT Processor, and the Output Adaptation Unit, which converts the two streams of outputs of the FFT Processor to one stream of samples in natural order.

The FFT Processor, in turn, consists of n Butterfly Units, one for each stage of Fig. 1 and n-1 Shuffling Units, where $n=\log_2N$. The Shuffling Units are responsible for the rearrangement of the data between two successive Butterfly

C. Meletis is with the National Technical University of Athens, 157 73 Zographou, Athens, Greece. E-mail: chris@microlab.ntua.gr.

P. Bougas is with with the National Technical University of Athens, 157 73 Zographou, Athens, Greece. E-mail: paul@microlab.ntua.gr.

G. Economakos is with the National Technical University of Athens, 157 73 Zographou, Athens, Greece. E-mail: geconom@microlab.ntua.gr.

P. Kalivas is with with the National Technical University of Athens, 157 73 Zographou, Athens, Greece. E-mail: paraskevas@microlab.ntua.gr.

K. Z. Pekmestzi is with with the National Technical University of Athens, 157 73 Zographou, Athens, Greece. E-mail: pekmes@microlab.ntua.gr.

Units.

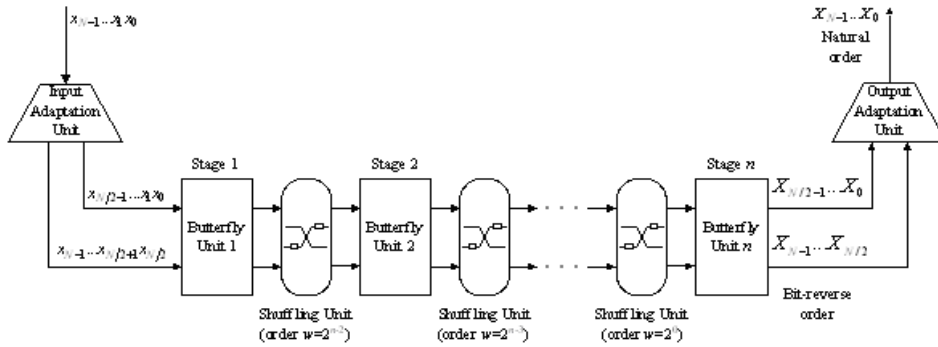

Fig. 1 . Block diagram of the circuit implementing the N -point Radix-2 DIF FFT

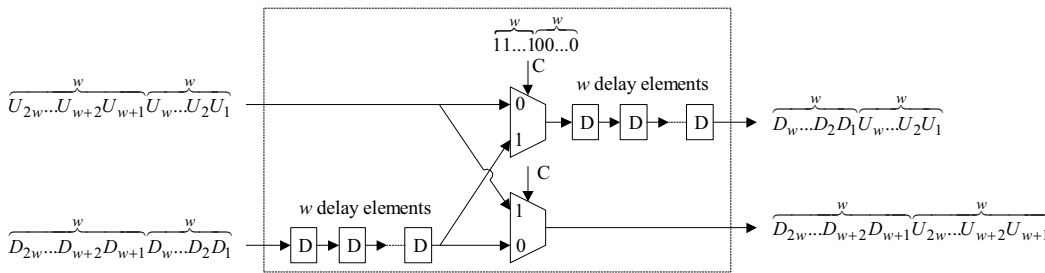

Fig. 2. The circuit of the Shuffling Unit of order w

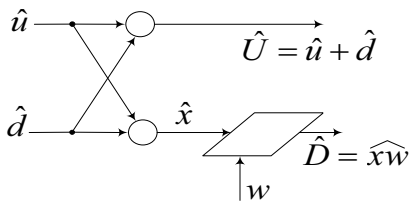

Fig. 3. Butterfly Unit for Radix-2 DIF FFT

The Shuffling Units are implemented using the circuit shown in Fig. 2. This circuit consists of $2w$ delay elements for the synchronization of the outputs of the previous Butterfly Unit and two multiplexers that perform the routing of the outputs to the corresponding inputs of the next Butterfly Unit.

The control signal C of the multiplexers takes the value “0” for w clock cycles, so that the upper outputs of the Butterfly Unit of stage s is delayed w clock cycles and routed to the upper input of the Butterfly Unit of stage $s+1$. Next, the control signal C takes the value “1” for another w clock cycles, so that the upper output is routed to the lower input while at the same time the lower output of the Butterfly Unit of stage s , which has already been delayed w clock cycles, is delayed another w clock cycles and routed to the upper input of the Butterfly Unit of stage $s+1$. Finally, the control signal C

takes the value “0” for another w clock cycles so that the lower output of the Butterfly Unit of stage s , which has already been delayed w clock cycles is routed to

the lower input of the Butterfly Unit of stage $s+1$ while at the same time, the first step of the procedure described above is repeated. For each stage s this procedure is repeated

$\frac{N/2}{2w} = 2^{s-1}$ times. If f is the operating frequency of the circuit then the frequency of the control signal

$C = \overbrace{11\dots1}^w \overbrace{00\dots0}^w$ is $f/2w$ and the latency of the Shuffling Unit is w .

Most modern communication systems need the computation of the FFT of a stream of samples in natural order ($\dots x_N \dots x_1 x_0$). Therefore, an Input Adaptation Unit is needed so the architecture proposed can process such a stream of samples. Furthermore, an Output Adaptation Unit is needed in order to convert the output sequence of the last Butterfly Unit, which is given in bit-reverse order, to one stream of samples in natural order. The reverse operation for the formation of the output stream of samples is performed by the Output Adaptation Unit. Detailed memory-based implementations of these circuits are included in final form of the paper.

I. BUTTERFLY UNIT

To obtain high-speed operation parallel bit-level pipelined implementation is adopted.

Also bit-skew number format is selected in order to avoid arithmetic circuits for numbers in Redundant representation, which are in general more complex. In addition, such a representation will double the hardware of the Shuffling Units.

Let us consider the individual parts of the Butterfly Unit (B.U.) of Fig.3. The bit-skew form of a number x is represented by the symbol \hat{x} . In Fig.4 the implementation of a bit-skew adder is shown. By inserting inverters at the inputs u and cin a similar circuit can be used for subtraction. The inputs d and u and the outputs ($d+u$, $d-u$) of the adder and the subtractor are all in bit-skew form.

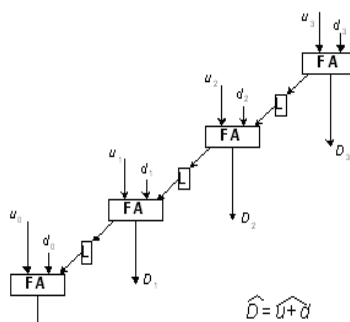

Fig. 4. Bit-skew numbers adder

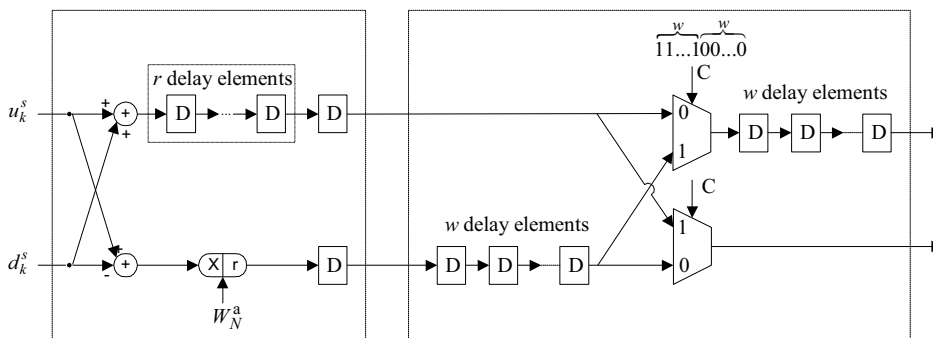

Fig. 5. Redundancy of the delay elements in the connection of the Butterfly Unit with the Shuffling Unit when pipeline multipliers are use for the implementation of the DIF FFT

The outputs are obtained with one clock cycle latency. In general the inputs (u,d) and the outputs (U, D) of the B.U. are complex numbers. For a more elegant presentation, the concept of complex binary digits is used [9].

The complex bit-skew form output of the subtractor enter to a bit-level pipelined carry-save complex array multiplier and the result is also in complex bit-skew form. Array multiplier form is selected instead of a Wallace Tree because of its canonical structure permitting higher operation speed. Detailed design (Full-Adder level pipelined and two's complement number format) of this multiplier will be included in the final form of the paper. There is no need to de-skew the B.U. outputs since Shuffling Units can handle the numbers directly in bit-skew form. Notice that the switches of the Shuffling Units must be control by similar bit-skew signal that can be easily produced using a shift register inside each unit.

I. PERFORMANCE

If the Butterfly Unit is implemented using a complex bit-skew number carry-save array pipeline multiplier [5] instead of combinational then the circuit of Fig. 1 has an additional

latency of r clock cycles, equal to the number of the pipeline stages, for every Butterfly Unit. In this case, additional r delay elements must be added to the upper line of the butterfly unit, as shown in Fig. 5, in order to synchronize the output of the complex multiplier with the output of the upper adder.

As can be seen in Fig. 1, for the implementation of DIF FFT Processor when using pipeline multipliers, every Shuffling Unit is preceded by a Butterfly Unit. In this case, the delay elements of each Shuffling Unit are preceded by the multiplier of the Butterfly Unit, as is also shown in the figure. Therefore, the latency of the multiplier can play the role of some of the w delay elements of the Shuffling Unit.

With this architecture a 100% hardware use is achieved, since all the Shuffling and Butterfly Units are utilized in every clock cycle. Therefore, this circuit can process two samples per clock cycle and compute a full N -point FFT in $N/2$ clock cycles. Since the circuit is fully pipelined, we can provide the samples of a new FFT right after the last sample (x_{N-1}) of the previous FFT and get the results right after the last result (X_{N-1}) of the previous FFT.

TABLE I illustrates the characteristics, hardware usage and performance, of various implementations of the FFT. The

architecture proposed has the same speed performance with [2] J. Choi and V. Boriakoff, "A new linear systolic array for FFT

TABLE I.
HARDWARE UTILIZATION AND PERFORMANCE OF VARIOUS ARCHITECTURES FOR THE IMPLEMENTATION OF THE N-POINT FFT

Architecture	Complex Multipliers	Complex Adders	Delay elements	Clock cycles per FFT	Latency
J. Choi and V. Boriakoff [2]	$\log_2 N$	$2\log_2 N$	$N\log_2 N$	$N/2$	$(\log_2 N - 1)N/2$
V. Boriakoff [3]	$3\log_2 N$	$3\log_2 N$	$2N + 5\log_2 N + 2$	N	$N + \log_2 N + 1$
C.Chang, C.Wang and Y.Chang [1]	$\log_2 N$	$2\log_2 N$	$N + \log_2 N - 1$	N	$N + \log_2 N - 1$
Architecture Proposed	$\log_2 N$	$2\log_2 N$	$N + 2\log_2 N - 2$	$N/2$	$N/2 + \log_2 N - 1^*$

* Latency of the FFT processor not including the latency of the Input and Output Adaptation Units.

the architecture in [2] but requires significantly less delay elements ($N-2$ instead of $N\log_2 N$). In addition, the latency of the circuit of the architecture proposed is significantly smaller since the architecture in [2] is based on the constant geometry radix-2 FFT algorithm. Furthermore, by using less hardware than [3] and almost the same hardware with [1] it can compute the FFT in half the clock cycles needed in [1] and [3], since 100% hardware use is achieved. Consequently, the architecture proposed yields a double speed performance having almost half the latency.

A great advantage of the architecture proposed for the DIF FFT is that it can operate with pipeline instead of combinational multipliers, with a slight impact on the latency of the circuit. For $N=1024$, in the architecture in [1] and [3] the latencies are 1033 and 1035 clock cycles respectively. For implementation with pipeline multipliers the latencies become 1133 and 1135 clock cycles respectively. In the architecture proposed, the corresponding latencies are 521 and 556 clock cycles.

II. CONCLUSIONS

A novel architecture has been proposed for the efficient implementation of the N-point FFT, where N is a power of two, based on the Radix-2 Decimation In Frequency (DIF). The circuit requires $\log_2 N$ Butterfly Units, namely $\log_2 N$ complex-number multipliers and $2\log_2 N$ complex-number adders, and $N + 2\log_2 N - 2$ delay elements. It is capable of processing two samples every clock cycle, therefore it requires $N/2$ clock cycles for the computation of the N-point FFT. This architecture is suitable for applications where computation of the FFT on a high bit-rate stream of data is required. The operation speed is limited by the delay of a gated Full-Adder. In addition, a special bit-skew array pipeline multiplier that is efficient in terms of latency and delay elements is proposed. Our research team prepares on Synopsys design tool an FFT core ASIC implementation ($\sim 4M$ Transistors) for GHz signals real-time spectral analysis. Results will be given in the final form of the paper.

REFERENCES

- [1] C.-H. Chang, C.-L. Wang, Y.-T. Chang, "Efficient VLSI architectures for fast computation of the discrete Fourier transform and its inverse," IEEE Trans. on Signal Processing, vol. 48, Nov. 2000, pp. 3206-3216.

- computation," IEEE Trans. Circuits Syst. II, vol. 39, Apr. 1992, pp. 236-239.
- [3] V. Boriakoff, "FFT computation with systolic arrays, a new architecture," IEEE Trans. Circuits Syst. II, vol. 41, Apr. 1994, pp. 278-284.
- [4] L.-W. Chang and M.-Y. Wu, "A new systolic array for discrete Fourier transform," IEEE Trans. Acoust., Speech, Signal Processing, vol.36, Oct. 1988, pp.1165-1167.
- [5] N. R. Murphy and M. N. S. Swamy, "On the real-time computation of DFT and DCT through systolic architecture," IEEE Trans. Signal Processing, vol. 42, Apr. 1993, pp. 988-991.
- [6] E. H. Wold and A. M. Despain, "Pipeline and parallel-pipeline FFT processors for VLSI implementations," IEEE Trans. On Computers, vol. C-33, No 5, pp. 414-426, May 1984.
- [7] N. Weste and D. J. Skellern, "VLSI for OFDM," IEEE Communications Magazine, pp. 127-131, Oct. 1998
- [8] E. Bidet, D. Castelain, C. Joanblanq and P. Senn, "A Fast-Chip implementation of 8192 complex point FFT," IEEE Journal of Solid-State Circuits, vol 30, No.3, pp. 300-305, March 1995.
- [9] K. Z. Pekmestzi, "Complex number multipliers," IEE Proceedings, Vol.136, Part E, No. 1, pp. 70-75, Jan. 1989.