

High Gain Mobile Base Station Antenna Using Curved Woodpile EBG Technique

P. Kamphikul, P. Krachodnok, R. Wongsan

Abstract—This paper presents the gain improvement of a sector antenna for mobile phone base station by using the new technique to enhance its gain for microstrip antenna (MSA) array without construction enlargement. The curved woodpile Electromagnetic Band Gap (EBG) has been utilized to improve the gain instead. The advantages of this proposed antenna are reducing the length of MSAs array but providing the higher gain and easy fabrication and installation. Moreover, it provides a fan-shaped radiation pattern, wide in the horizontal direction and relatively narrow in the vertical direction, which appropriate for mobile phone base station. The paper also presents the design procedures of a 1x8 MSAs array associated with U-shaped reflector for decreasing their back and side lobes. The fabricated curved woodpile EBG exhibits bandgap characteristics at 2.1 GHz and is utilized for realizing a resonant cavity of MSAs array. This idea has been verified by both the Computer Simulation Technology (CST) software and experimental results. As the results, the fabricated proposed antenna achieves a high gain of 20.3 dB and the half-power beam widths in the E- and H-plane of 36.8 and 8.7 degrees, respectively. Good qualitative agreement between measured and simulated results of the proposed antenna was obtained.

Keywords—Gain Improvement, Microstrip Antenna Array, Electromagnetic Band Gap, Base Station.

I. INTRODUCTION

NOWADAYS, wireless communication is used increasingly because users can connect to the network system from any area within the signal coverage range, so the users can conveniently connect to the system. From the development of wireless communication system, the antennas were improved with new performances becomes currently imperatively essential for the new services and network of telecommunication. Microstrip antennas (MSA) are an attractive choice for many modern communication systems due to their light weight, low profile, conformable to planar and nonplanar surfaces, inexpensive to manufacture using modern printed-circuit technology, and versatile in terms of resonant frequency, polarization, pattern, and impedance [1]-[2]. However, two of the important disadvantages of MSA are the low gain and very narrow impedance bandwidth due to the resonant nature of the conventional MSA. Parasitic patches are used to form a multi-resonant circuit so that the operating bandwidth can be improved [3]. A multi-layer MSA is examined with parasitic patches stacked on the top of the main patch [4]. The multi-resonant conducts to be realized by

incorporating slots into the metal patch. In addition, several single-layer single-patch MSA have been presented, such as the U-slot MSA [5] and the E-shaped patch antenna [6]. Another major topic in MSA designs is to miniaturize the patch antenna size such as increasing the dielectric constant of the substrate is also a simple and effective ways for reducing the antenna size [7]. Nevertheless, there are significant drawbacks with the use of high dielectric constant substrate such as narrow bandwidth, low radiation efficiency, and poor radiation patterns, which result from strong surface waves excited in the substrate. The narrow bandwidth can be expanded by increasing the substrate thickness, which, however, will launch stronger surface waves. As a result, the radiation efficiency and patterns of the antenna will be further degraded.

Numerous new technologies have emerged in the modern MSA design arena and one exciting breakthrough is the development of Electromagnetic Band Gap (EBG) structures. The applications of EBG structures in antenna designs have become a thrilling topic for antenna engineering. Besides that, EBG structures, also known as photonic crystals [8], have attracted increasing interests because of their desirable electromagnetic properties that cannot be observed in natural material (metamaterials). Many researches on EBG structures are on the initiate in the electromagnetic and antenna community such as low profile antennas, active phased array, TEM waveguides, and microwave filters [9]. The unique electromagnetic properties of EBG structures have led to a wide range of applications in MSA engineering because the EBG structures can be integrated into MSA designs and their surface wave band gap property helps to increase the antenna gain, minimize the side and back lobes, and reduce mutual coupling in array elements [10]-[12]. These structures have the ability to open a bandgap, which is a frequency range for which the propagation of electromagnetic waves is forbidden. This is due to EBG exhibits frequency band-pass and band-stop that can block the surface wave excitation in the operational frequency range of antennas [13]. From such advantages of EBG structures, this paper presents a 1x8 MSAs array with U-shaped reflector and curved woodpile EBG structures providing the high gain and beamwidth suitable for mobile phone base station. The simulated from CST software and measured results of the reflection coefficient (S_{11}), radiation patterns, and gain of the proposed antenna show good agreement which are presented.

This paper is organized as follows. In Section II, the configuration and design of the circular MSA is introduced. In addition, a curved woodpile EBG structure with its

P. Kamphikul, P. Krachodnok, and R. Wongsan are with the School of Telecommunication Engineering, Institute of Engineering, Suranaree University of Technology, Nakhon Ratchasima, CO 30000 Thailand (phone: +668 1955 2414; fax: +66 4422 4603 e-mail: D5240395@g.sut.ac.th, priam@sut.ac.th, and rangsan@sut.ac.th).

corresponding bandgap features is presented in Section III. In Section IV, we apply this approach into the simulated results and discussions. Next, the fabricated and experimented results of the prototype antenna are discussed in the Section V, followed by conclusions in Section VI.

II. MSA CONFIGURATION

A. A Circular MSA

The circular MSA [14], the most common radiating patch because of ease of analysis and fabrication, and low cross-polarization radiation, designed for working in the Universal Mobile Telecommunications System (UMTS) band of 2.1 GHz frequency is utilized by the prototype for this proposed antenna. The antenna is printed on FR4 ($\epsilon_r = 4.5, \tan\delta = 0.02$) substrate with the size of 60 mm x 60 mm and the thickness of 1.6 mm. A circular MSA structure consists of the circular patch of the radius (a). This gap of distance (t) between the microstrip line length (L_2) is used for adjusting the impedance matching. These structures mounted on the dielectric substrate with the dielectric constant of ϵ_r and the height (h). The substrate is located on the ground plane of the width (W) and the length (L). This ground plane is cut to form the wide-slot ground plane (Size $W_1 \times L_1$). The design of a MSA is based on the conventional transmission line model at 2.1 GHz. The desired bandwidth is 1.920 – 2.170 GHz. The tuning stub is used to improve the level of reflection coefficient, while the microstrip line is designed to provide 50 Ohm at the operating frequency of 2.1 GHz. The dimension of the wide-slot ground plane is varied to enhance the bandwidth as illustrated in [14]. The simulated result shows that the gain at 2.1 GHz is 5 dB.

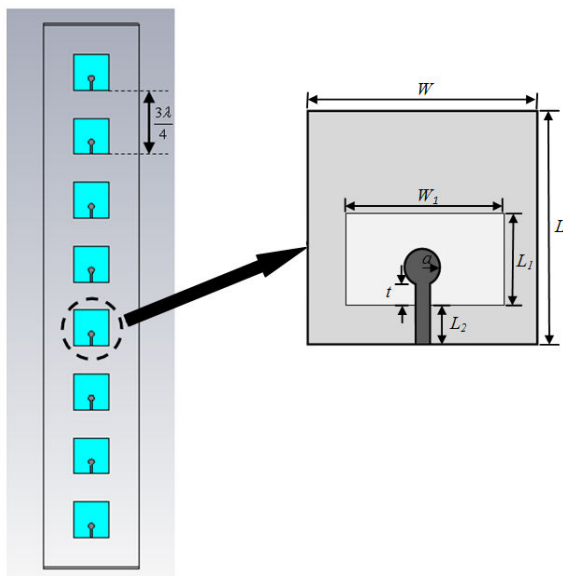

Fig. 1 A 1×8 array of circular MSAs (antenna type A)

B. A 1×8 MSAs Array

To improve gain characteristic, a circular MSA will be arrayed with element spacing of $3\lambda/4$ (antenna type A) as

shown in Fig. 1. In addition, the proposed antenna in this paper has added a U-shaped reflector with the size of 400 mm x 1,000 mm behind the panel of MSAs array to control the radiation pattern to be the directional pattern. Fig. 2 shows a 1×8 array of circular MSAs and U-shaped reflector (antenna type B). The simulated results show that the radiation patterns of the antenna type A and B at 2.1 GHz with the gain of 14 and 17.83 dB, respectively. The Half-Power Beamwidth (HPBW) in the H- and E-Plane, which shown as the ratio of azimuth pattern to evaluation pattern (AZ:EL), of the array antenna type A and B are $97.4^\circ:8.4^\circ$ and $89.4^\circ:8.3^\circ$, respectively.

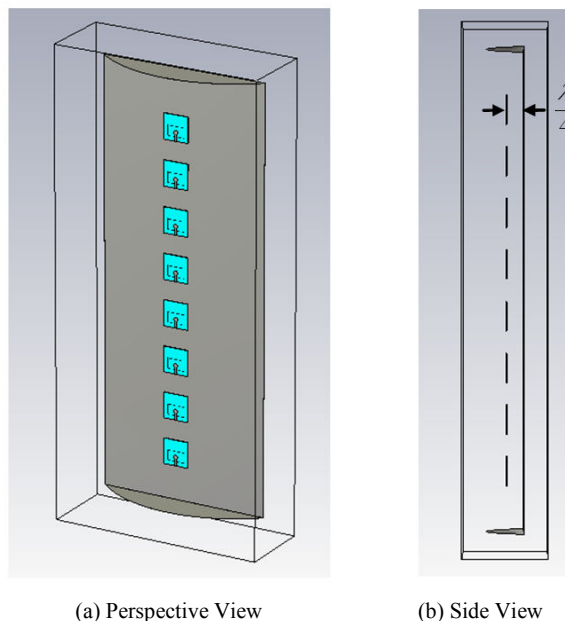
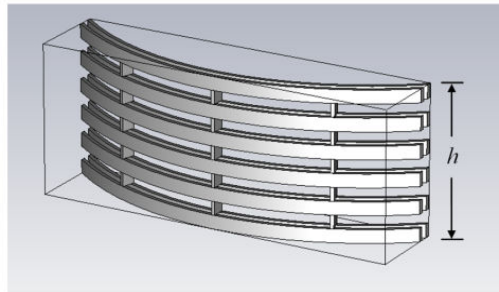

Fig. 2 A 1×8 array of circular MSAs and U-shaped reflector (antenna type B)

III. EBG CONFIGURATION

In this section, the modified array antenna type B has been increased the gain by using new technique of woodpile EBG structures instead. In the past, the conventional method for gain increment, a lot of elements will be added in the array, which causes the dimension of antenna is too long and its weight is too heavy. Furthermore, the great number of electromagnetic energy will be lost inside the phasing line. From our study [15]-[18], we found that the proper structure of EBG is capable to enhance the gain of MSAs array as the additional resonant circuit which installed at front of the array panel. Moreover, the EBG structures can be appropriately shaped such as planar woodpile EBG structures for reducing the side and back lobes of the directional antenna too [19]-[20]. From investigation, the sector of cylindrical woodpile EBG structures [21] are more suitable for the antenna type B. Fig. 3 shows the geometry of the curved woodpile EBG structures with two layers of the different diameters. The parameters for these structures are the filament thickness or diameter (w), the radius (R), the height (h), the number of

radial filaments (N_{rad}), and the number of rings (N_{ring}) of the curved. To implement the curved woodpile EBG, we have used alumina rods (rectangular cross section) with parameters $\epsilon_r = 8.4$ and $\tan\delta = 0.002$. The parameters are given as follow [18] with $w = 0.05\lambda$, $R = 3.05\lambda$, $h = 1.23\lambda$, $N_{rad} = 3$, and $N_{ring} = 2$.



(a) Perspective View

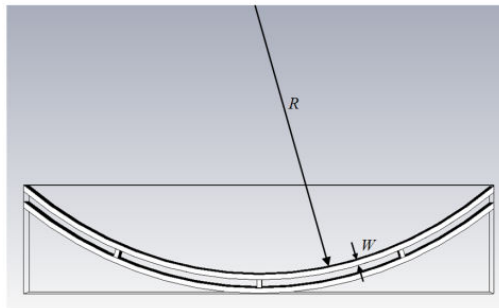

(b) Top View

Fig. 3 The geometry of the sector of curved woodpile EBG structures

IV. SIMULATED RESULTS AND DISCUSSIONS

The gain improvement of a 1×8 array of circular MSAs and U-shaped reflector with curved woodpile EBG structures (antenna type C) was simulated by CST software as shown in Fig. 4.

The design parameters of the gain improvement for an antenna type C are the radius of curved woodpile EBG structures (R), the distance between a 1×8 circular MSAs array and curved woodpile EBG structures (d), and the height of curved woodpile EBG structures (h) [22]. Firstly, we look at the effect of the variation of R , d and h are fixed at 0λ and 1.23λ , respectively. Fig. 5 shows the gain against the R at operating frequency of 2.1 GHz. The highest gain of 18.72 dB is provided at R is around at 3.34λ . Also, the appropriate HPBW in the H-plane appears at same radius of R of curved woodpile EBG, while its HPBW will be enlarged when the dimension of R increased. Secondly, we have investigated the effect of the distance d , while R and h are fixed at 3.34λ and 1.23λ , respectively. We note that the highest gain of 18.72 dB is achieved when $d = 0\lambda$ as shown in Fig. 6. This property can be used to control the resonant frequency of curved woodpile EBG structures because its resonant frequency will change

when d is changed, while the bandwidth is constant. Next, we have studied the effect of the h variation versus the gain, R and d are fixed at 3.34λ and 0λ , respectively, thus its result is improved as shown in Fig. 7. We found that the gain is increased from 18.72 dB to 20.84 dB at h equals to 3.91λ approximately. Although the gain increases when h also increases, while h is higher than 5.25λ , it will be mismatched and operating frequency of bandwidth will be shifted to the undesired frequency.

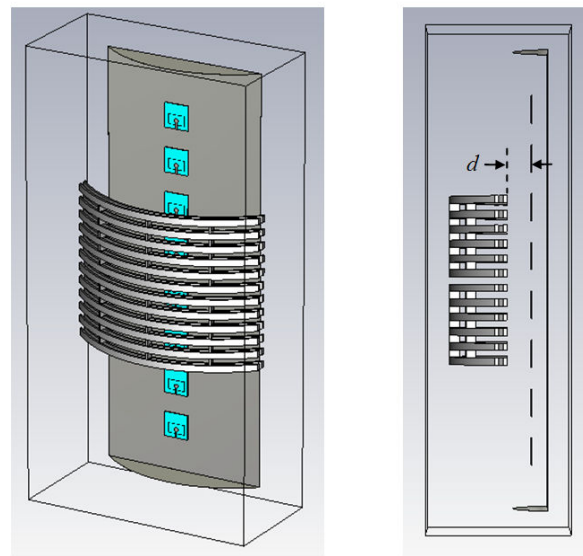

(a) Perspective View

(b) Side View

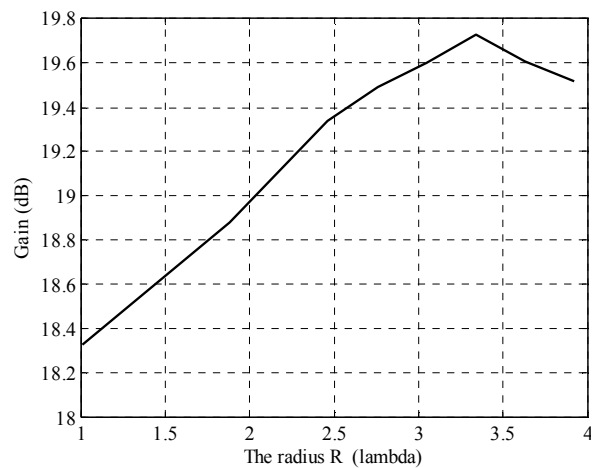
Fig. 4 A 1×8 MSAs array with U-shaped reflector and curved woodpile EBG structures (antenna type C)Fig. 5 Simulated gain against R of the antenna type C

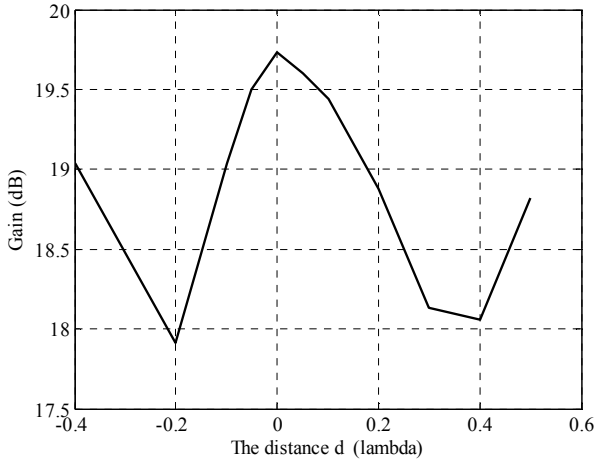

Fig. 6 Simulated gain against d of the antenna type C

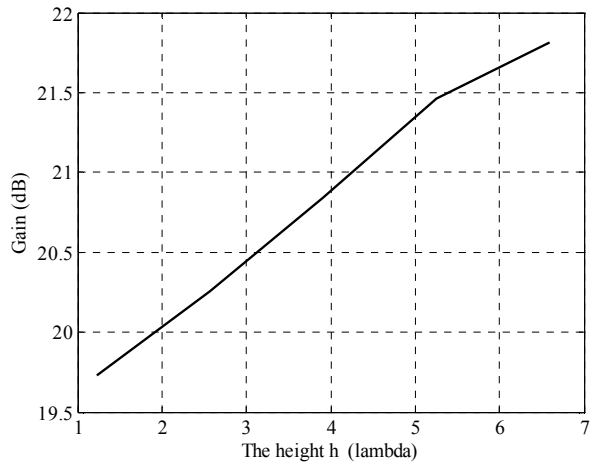

Fig. 7 Simulated gain against h of the antenna type C

Finally, the highest gain of an antenna type C is optimized with $R = 3.34\lambda$, $d = 0\lambda$, and $h=3.91\lambda$. The S_{11} (-10 dB) of the antenna type A, B, and C, covered 1.920 to 2.170 GHz, which are wide enough and can be well utilized for 3G mobile phone base station as shown in Fig. 8. Fig. 9 shows the normalized radiation patterns at 2.1 GHz of the antenna type A, B, and C. Although its HPBW of the antenna type C will narrow, but it can cover the desired service area of mobile phone base station and still provides the higher gain. Also, the HPBW, the Side Lobe Level (SLL), and the gain of the antenna type A, B, and C are shown in Table I.

TABLE I
RESULTS OF SIMULATION

Parameters	Antenna type A	Antenna type B	Antenna type C
The HPBW (AZ:EL)	97.4°:8.4°	89.4°:8.3°	37.2°:8.7°
The E-plane SLL	-12.9 dB	-13.2 dB	-14.4 dB
The H-plane SLL	-	-30.6 dB	-27.3 dB
The Gain	14 dB	17.83 dB	20.84 dB

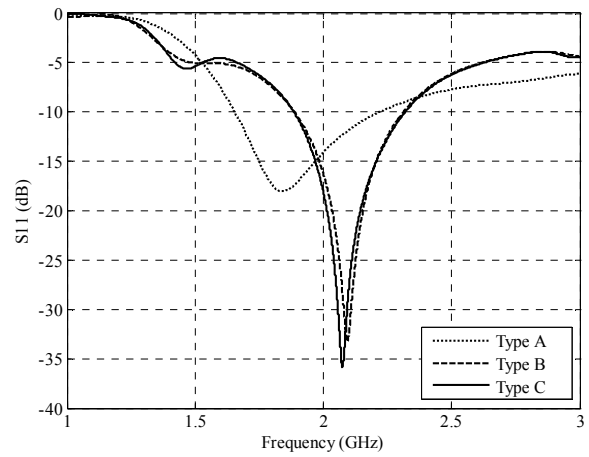
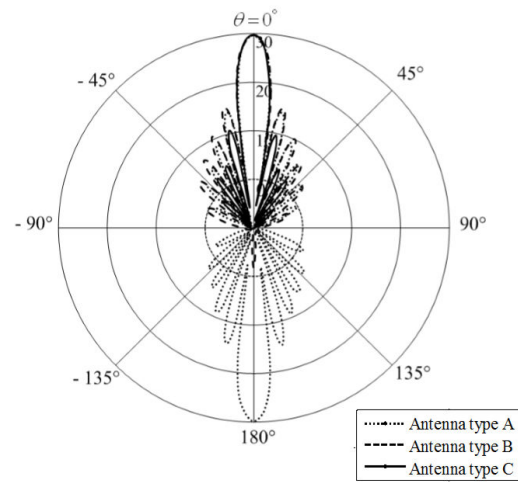
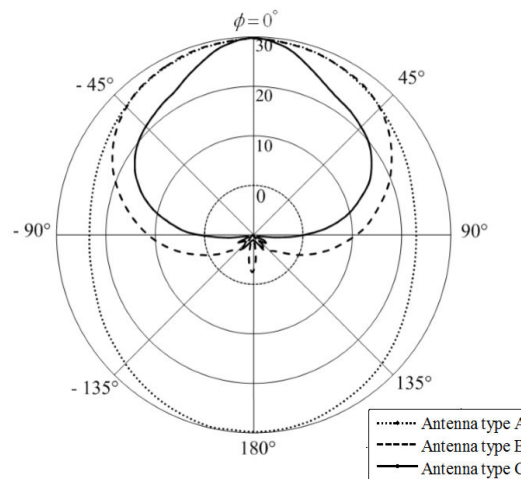

Fig. 8 Simulated reflection coefficient of the three type antennas



(a) E-Plane



(b) H-Plane

Fig. 9 Simulated radiation patterns of the three type antennas

V. EXPERIMENTAL RESULTS AND DISCUSSIONS

An antenna type *C* prototype has been simulated with the CST software and fabricated to validate the proposed concept. The geometry of an antenna type *C* prototype as shown in Fig. 4 is used. It consists of a 1x8 circular MSAs array, with element spacing of $3\lambda/4$, associated with U-shaped reflector, as a PEC reflector to decrease their back and side lobes and control the radiation pattern to be the directional pattern, and the curved woodpile EBG structures which exhibit bandgap characteristics at 2.1 GHz and are utilized for realizing a resonant cavity of MSAs array. Figs. 10 shows photograph of the fabricated the proposed antenna. The simulated and measured S_{11} of the antenna are shown in Fig. 11. A good agreement is obtained between calculated and measured results. From the measured curve, a bandwidth from 1.54 to 3 GHz (a fractional bandwidth of 64.32%) is achieved, which is enough to cover the 3G mobile phone base station, UMTS band of 2.1 GHz (1.920 to 2.170 GHz). A further study of the proposed antenna has focused on its radiation performance. The radiation patterns of the proposed antenna were measured in an outdoor. For comparison, numerical simulations for radiation patterns were also carried out using the CST software. The measured and simulated patterns are shown in Fig. 12. With reference to these curves, a good agreement between predictions and measured data can be observed. The HPBW in the H- and E-Plane, which shown as the ratio of azimuth pattern to elevation pattern (AZ:EL), of the proposed antenna is $36.8^\circ:8.7^\circ(4.23:1)$. Note that the radiation patterns provide a fan-shaped pattern, a main beam having a narrow beamwidth in the vertical direction and a wider beamwidth in the horizontal direction, which appropriate for mobile phone base station. The measured gain of the proposed antenna is 20.3 dB at operating frequency of 2.1 GHz. In additional, the measured and simulated results of the HPBWs, the SLLs, and the gains of the proposed antenna are summarized in Table II. These measurements of the proposed antenna are unique and very positives. With such features, this antenna is suitable for a mobile phone base station.

TABLE II
RESULTS OF MEASUREMENT

Parameters	Simulated Results	Measured Results
The HPBW (AZ:EL)	$37.2^\circ:8.7^\circ$ 4.3:1	$36.8^\circ:8.7^\circ$ 4.23:1
The E-plane SLL	-14.4 dB	-14 dB
The H-plane SLL	-27.3 dB	-25.3 dB
The Gain	20.84 dB	20.3 dB



Fig. 10 The prototype of the proposed antenna

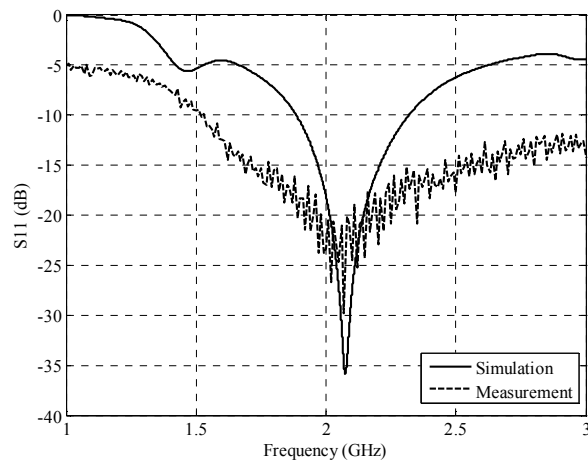

Fig. 11 The reflection coefficient of the proposed antenna

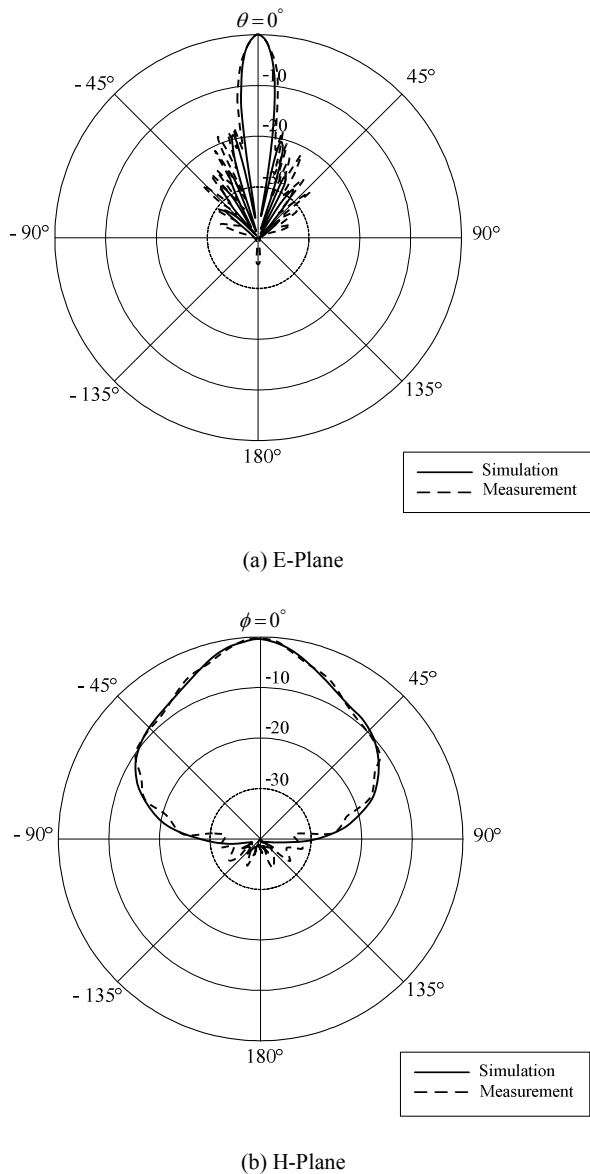

Fig. 12 The normalized radiation patterns of the proposed antenna

VI. CONCLUSIONS

This paper presented a sector antenna of a 1×8 MSAs array for mobile phone base station by modifying the bidirectional circular MSAs array to be the directional antenna by adding U-shaped reflector and increasing its gain with new technique, obviously, the proposed antenna provided the directive gain increasing around 3 dB when such EBG structures were added, while its length of array was not enlarged. Moreover, a fan-shaped radiation pattern in the horizontal direction according to our requirement was obtained. The most important technique for this accomplishment that is the EBG structures must be appropriately designed and calculated, especially the radius of the sectorial cylinder of woodpile EBG structures. The most proper radius of 3.34λ , the distance

between a 1×8 MSAs array and curved woodpile EBG structures of 0λ , and the height of curved woodpile EBG of 3.91λ can provide the moderately highest gain of 20.3 dB at the operating frequency of 2.1 GHz. A good agreement is obtained between simulated with CST software and experimental results. Therefore, this proposed antenna accords to the requirements and is appropriated for a sector antenna of 3G mobile phone base station, UMTS band of 2.1 GHz.

ACKNOWLEDGMENT

This work was supported by the National Research Council of Thailand (NRCT) and the Research Department Institute of Engineering, Suranaree University of Technology, Nakhon Ratchasima, Thailand.

REFERENCES

- [1] J.J. Bahl and P. Bhartia, "Microstrip Antennas," Artech House, 1980.
- [2] P. Bhartia, InderBahl, R. Garg, and A. Ittipipoon, "Microstrip Antennas Design Handbook," Artech House, 2000.
- [3] G. Kumar and K. C. Gupta, "Directly coupled multiple resonator wide-band microstrip antenna," *IEEE Transactions on Antennas and Propagation*, Vol. 33, No. 6, 1985, pp. 588-593.
- [4] D. M. Pozar, "Microstrip antenna aperture-coupled to a microstripline," *Electronics Letters*, Vol. 21, No. 2, 1985, pp. 49-50.
- [5] T. Huynh and K. F. Lee, "Single-layer single-patch wide band microstrip antenna," *Electronics Letters*, Vol. 31, No. 16, 1995, pp. 1310-1312.
- [6] F. Yang, X. Zhang, X. Ye, and Y. Rahmat-Samii, "Wide band E-shaped patch antennas for wireless communications," *IEEE Transactions on Antennas and Propagation*, Vol. 49, No. 7, 2001, pp. 1094-1100.
- [7] T. K. Lo, C.-O. Ho, Y. Hwang, E. K. W. Lam, and B. Lee, "Miniature aperture coupled microstrip antenna of very high permittivity," *Electronics Letters*, Vol. 33, No. 1, 1997, pp. 9-10.
- [8] J. D. Joannopoulos, R. D. Meade and J. N. Winn, "Photonic Crystals: Molding the Flow of Light," Princeton University Press, New Jersey, 1995.
- [9] F. Yang and Y. Rahmat-Samii, "Electromagnetic Band Gap Structures in Antenna Engineering," Cambridge University Press, Cambridge, 2009.
- [10] R. Gonzalo, P. de Maagt, and M. Sorolla, "Enhanced path-antenna performance by suppressing surface waves using photonic-bandgap substrates," *IEEE Transactions on Microwave Theory and Techniques*, Vol. 47, No. 11, 1999, pp. 2131-2138.
- [11] N. Llobart, A. Neto, G. Gerini, and P. de Maagt, "Planar circularly symmetric EBG structures for reducing surface waves in printed antennas," *IEEE Transactions on Antennas and Propagation*, Vol. 53, No. 10, 2005, pp. 3210-3218.
- [12] Illuz, Z., R. Shavit and R. Bauer, "Micro-strip Antenna Phased Array with Electromagnetic Band-Gap Substrate," *IEEE Transactions on Antennas and Propagation*, Vol. 52, No. 6, 2004, pp. 1446-1453.
- [13] F. Yang and Y. Rahmat-Samii, "Microstrip antennas integrated with electromagnetic bandgap (EBG) structures: A low mutual coupling design for array applications," *IEEE Transactions on Antennas and Propagation*, Vol. 51, No. 10, 2003, pp. 2936-2946.
- [14] Y. Chawanonphithak and C. Phongcharoenpanich, "An Ultra-wideband Circular Microstrip Antenna fed by Microstrip Line above Wide-Slot Ground Plane," in *Communications, (APCC) 2007. Asia-Pacific Conference on Communications*, Bangkok, Thailand, October 2007.
- [15] P. Kamphikul, P. Krachodnok, and R. Wongsan, "High-Gain Antenna for Base Station Using MSA and Triangular EBG Cavity," in *The 2012 Progress in Electromagnetics Research Symposium (PIERS 2012)*, Kuala Lumpur, Malaysia, March 2012, pp. 534-537.
- [16] P. Kamphikul, P. Krachodnok, and R. Wongsan, "Gain Improvement of MSA Array for Base Station using Covered EBG," in *The 2012 Asia-Pacific Conference on Antennas and Propagation (APCAP 2012)*, Singapore, August 2012, pp. 193-194.

- [17] P. Kamphikul, P. Krachodnok, and R. Wongsan, "Beamwidth Improvement of MSA Array for Base Station Using Covered with Curved Woodpile EBG," in *Thailand-Japan MicroWave 2012 (TJMW 2012)*, Bangkok, Thailand, August 2012.
- [18] P. Kamphikul, P. Krachodnok, and R. Wongsan, "Gain Improvement of MSAs Array by Using Curved Woodpile EBG and U-shaped Reflector," in *The 2014 International Electrical Engineering Congress (iEECON 2014)*, Pattaya City, Thailand, March 2014.
- [19] A.R. Weily, L. Horvath, K.P. Esselle, B. Sanders, and T. Bird, "A planar resonator antenna based on woodpile EBG material," *IEEE Transactions on Antennas and Propagation*, Vol. 53, No. 1, 2005, pp. 216–223.
- [20] Y. Lee, X. Lu, Y. Hao, S. Yang, J.R.G. Evans, and C.G. Parini, "Low profile directive millimeter-wave antennas using free formed three-dimensional (3D) electromagnetic band gap structures," *IEEE Transactions on Antennas and Propagation*, Vol. 57, No. 10, 2009, pp. 2893–2903.
- [21] Y. Lee, X. Lu, Y. Hao, S. Yang, J.R.G. Evans, and C.G. Parini, "Narrow-beam azimuthally omni-directional millimetre-wave antenna using free formed cylindrical woodpile cavity," *IET Microwaves, Antennas and Propagation*, Vol. 4, No. 10, 2010, pp. 1491–1499.
- [22] R. Wongsan, P. Krachodnok, and P. Kamphikul, "A Sector Antenna for Mobile Base Station using MSA Array with Curved Woodpile EBG," *Open Journal of Antennas and Propagation (OJAPr)*, Vol.2, No.1, 2014, pp. 1-8.



P.Kamphikul was born in Nakhon Ratchasima, Thailand, in 1984. She received the B.Eng. degree, the first class honors, and the M. Eng. degree in telecommunication engineering from Suranaree University of Technology, Thailand, in 2007 and 2009, respectively. She is currently working toward the Ph.D. degree in telecommunication engineering at Suranaree University of Technology.

Her research interests include electromagnetic theory, antenna engineering and Electromagnetic Band Gap.



P.Krachodnok was born in KhonKaen, Thailand, in 1974. She received the B.Eng. degree in telecommunication engineering from Suranaree University of Technology, Thailand, in 1997, M. Eng. degree in Electrical Engineering from Chulalongkorn University, Thailand, in 2001, and D.Eng. degree in telecommunication engineering from Suranaree University of Technology, Thailand, in 2008.

She received the APCC2007 Best paper award, IEEE Asia-Pacific Conference on Communications, Bangkok, Thailand. She is the reviewer of IEEE Conference. Her research interests are Electromagnetic Theory, Microwave Engineering, Antenna Engineering, and Electromagnetic Band Gap.

Assist Prof Dr. Krachodnok is the member of the Electrical Engineering/Electronics, Computer, Telecommunications and Information Technology Association (ECTI) and The Institute of Electronics, Information and Communication Engineers (IEICE).



R.Wongsan was born in Rayong, Thailand, in 1964. He received his B.Eng. degree in Electronics Engineering at Rajamangala Institute of Technology in 1989, Thewes campus, M.Eng. degree in Electrical Engineering at King Mongkut's Institute of Technology, North Bangkok (KMITNB) in 1994, and D.Eng. degree in Electrical Engineering at King Mongkut's Institute of Technology Ladkrabang (KMITL) in 2003.

At present, he is the reviewer of many journals related to the electromagnetic applications society. His almost researches are in the antenna theory and electromagnetic applications. Currently, his research interests are the utilization of the Electromagnetic Band Gap for the efficiency improvement of conventional antennas and microwave devices.

Assoc. Prof. Dr. Wongsan is the member of the Electrical Engineering/Electronics, Computer, Telecommunications and Information Technology Association (ECTI) and The Institute of Electronics, Information and Communication Engineers (IEICE).