

Fuzzy Sequential Algorithm for Discrimination and Decision Maker in Sporting Events

Mourad Moussa, Ali Douik, Hassani Messaoud

Abstract—Events discrimination and decision maker in sport field are the subject of many interesting studies in computer vision and artificial intelligence. A large volume of research has been conducted for automatic semantic event detection and summarization of sports videos. Indeed the results of these researches have a very significant contribution, as well to television broadcasts as to the football teams, since the result of sporting event can be reflected on the economic field. In this paper, we propose a novel fuzzy sequential technique which lead to discriminate events and specify the technico-tactics on going the game, nor the fuzzy system or the sequential one, may be able to respond to the asked question, in fact fuzzy process is not sufficient, it does not respect the chronological order according the time of various events, similarly the sequential process needs flexibility about the parameters used in this study, it may affect a membership degree of each parameter on the one hand and respect the sequencing of events for each frame on the other hand. Indeed this technique describes special events such as dribbling, headings, short sprints, rapid acceleration or deceleration, turning, jumping, kicking, ball occupation, and tackling according velocity vectors of the two players and the ball direction.

Keywords—Sequential process, Event detection, Soccer videos analysis, Fuzzy process, Spatio-temporal parameters.

I. INTRODUCTION

IN a few years many sports video analysis works have addressed soccer and various sports games. For soccer video, prior work has been on shot classification [1], scene reconstruction [2], and rule-based semantic classification [3]. For other sports video, supervised learning was used by Zhong and Chang [4] to recognize canonical views such as baseball pitching and tennis serve. In the area of video genre segmentation and classification, Y. Wang, Z. Liu and J. Huang have developed HMM-based models for classifying videos into news, commercial, sports and weather reports [5].

Among the major aims of sports video analysis is to provide assistance for training. There is a need to summarize the play tactics from video streams. Much research has been done on classifying a play sequence into an existing tactic pattern and recognizing unknown patterns. The examples include baseball tactics [6], soccer [7], American football [8], and tennis [9]. The techniques include multimodal integration, intermodal collaboration, semi-automatic annotation and feature classification [10]-[12]. The complexity of the games includes

M. Moussa is with the Department of Electrical Engineering, LARATSI Lab, National Engineers School of Monastir, Tunisia, (corresponding author e-mail: Mourad.enim@yahoo.fr).

A. Douik is with LARATSI Lab, National Engineers School of Monastir, (e-mail: Ali.Douik@enim.rnu.tn)

H. Messaoud is the Director of LARATSI Lab, National Engineers School of Monastir, Tunisia, (e-mail: Hassani.Messaoud@enim.rnu.tn).

structured games such as tennis, cricket, and unstructured sports such as soccer, American football, baseball and basketball. The performance of a soccer player is usually described by statistics gathered from matches or by intuitive ways of experts. The traditional statistics of soccer games, such as the number of goals, ratio of ball occupation, running distance, etc. are however abstract and insufficient to describe several aspects of performance. The intuitive description on players by experts is also subjective and often lacks of consistency, although it explains some qualitative aspects of players. In order to make a good strategy of soccer game, we need therefore a quantitative model to describe the ability of each soccer player.

The movement of an object is termed a trajectory; in other words, trajectory is the trace of the player in time.

The trajectory representation is adequate to derive certain properties and relationships of the object movement. Trajectories are characterized by a set of different properties depending on the application requirements. The most common properties are [13]:

- The speed of moving object
- The velocity of moving object
- The direction of movement

In this paper, we propose a novel fuzzy sequential technique which consists to discriminate both, events and the technico-tactics choice of each team such as, Ball possession (B.P), Dribbling (Drb), Offensive Phase (O. Ph), defensive Phase (D. Ph) and Ball interception (B.I), in the other word to discover the tactic strategies in broadcast soccer videos based on the extracted information as the movement's players and the sense of direction ball. As the salient objects in soccer games, the movement of players and ball is the type of useful information for tactic analysis. The velocities of players and displacement of ball and their relationships, ongoing the game can contribute to identify the tactic scenario used by the coach and generate statistical data base for improving the performance of players at different positions.

The rest of this paper is organized as follows: Related work will be presented in Section II. Section III describes a Gaussian's mixture technique, detecting objects from the images sequence. Section IV presents situation commonly criticized in broadcast soccer programs, which will be analysis. Sections V explain different phases constituting sequential technique, and events description; finally we conclude the paper in Section VI.

II. RELATED WORKS

A great number of works have been proposed to detect and track the motions and movements of players and ball from video data among these are mostly based on physics and statistical data. By statistical analysis, we cannot however fully understand every aspect of soccer players. We need more accurate models to describe both their performance in detail and sports event, one of which is by the trajectories of players and ball in instance express the performance of soccer players [14], using as input the relationships between the trajectories of players and a ball and having as output the performance evaluation of several players in a quantitative way. In a trajectory-based algorithm was proposed for automatically detecting and tracking ball from soccer video [15]. While this method was intended only for the detection and tracking of ball, another tracking method based on graph representation was proposed to discover the trajectories of players from video data in [16] and an interesting method for extracting trajectories from video with white lines of play field was also proposed by [17]. Other studies are found in [18], [19]. A review on extraction methods of motions and movements is given in [20]. Even though these methods cannot completely extract trajectories of ball and players due to several problems such as collisions, a large part of trajectories can be automatically collected by them.

Quantitative model was proposed to evaluate the ability of space management and cooperative movement in soccer by means of two factors, minimum moving time pattern and domain region [21]. Another interesting model to evaluate the strategic ability of soccer team was proposed by [22]. This model first introduces the notion of dominant region of player and then divides the soccer field into a number of cells of voronoi diagram to define dominant regions. Although these methods introduced measures to quantify the performance of players and team, they still remain primitive and do not fully exploit the nature of trajectories such as relationship analysis between trajectories.

A more elaborate model of the relationships between players was proposed by S.-L. Chin et al. for analyzing basketball defensive strategies [23]. In order to describe the local defensive movements of basketball players, they explored the spatiotemporal relationship extracted from video clips. This approach seems very attractive even though it concerns basketball. But their model is based on static relationships extracted from clips rather than trajectories and does not fully deal with the movements of players and ball. While a number of studies have been performed to describe the performance of players and analyze the strategy of soccer game, no rigorous model has been proposed for the relationship analysis of trajectories in soccer games. The objective of this paper is to provide a basis of formal model to analyze the relationships between extracted parameters of soccer players.

III. PLAY FIELD SEGMENTATION AND PLAYERS DETECTION

A. Introduction

Since a few years, pattern recognition approaches using statistical techniques to construct a detector have encountered great success in the domain of visual detection [24]. Automatic systems face three challenges: First, the poor appearance of objects in the scene due to various underwent deformations; second, the very low resolution of the treated images; third, the noise effects produced by the camera movements. Seeking of the appropriate color system representation may be the best solution to overcome these situations.

B. Players Detection

J.-L. Shih et al. [25] use the color features of an employee's uniform was extracted to identify the entrance legality in a restricted area of an open space. In this subsection The players detection in soccer game sequence, is based on the segmentation technique by Gaussian's mixture where we incorporate an algorithm which allows to specify the significant color levels leading to refine segmentation results by a minimized overlapping between different clusters, in fact this technique consists to model each class by a Gaussian distribution characterized by a mean value μ_j and variance σ_j^2 (Fig. 5). Chronological order of different phases which constitute this segmentation technique is presented by the following flow chart Fig. 1.

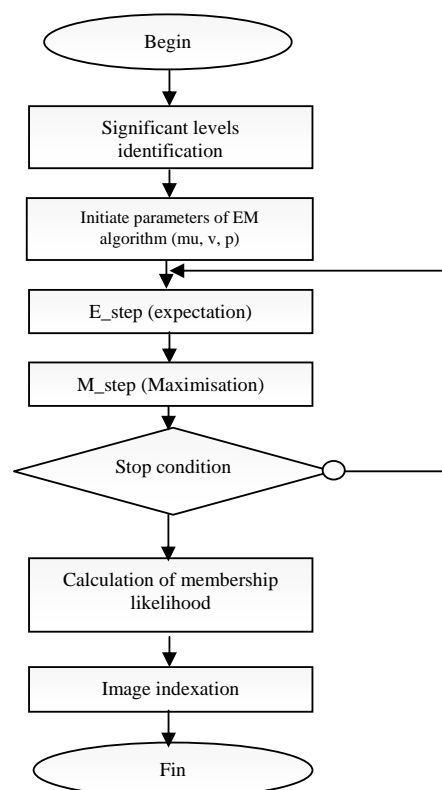

Fig. 1 Flow chart of used segmentation algorithm

Statistical segmentation's parameters are optimized by an iterative process known as Expectation-Maximisation algorithm. Likelihood density of mixture is expressed by:

$$f(y|z, \phi) = \sum_{j=1}^J \frac{p_j}{\sqrt{2\pi\sigma_j^2}} \exp\left[-\frac{(x-\mu_j)^2}{2\sigma_j^2}\right] \quad (1)$$

As it is shown in Fig. 2 mixture's likelihood density of three Gaussians ($j = 3$) for one shot among the described sequence, where each class is modeled by its own distribution.

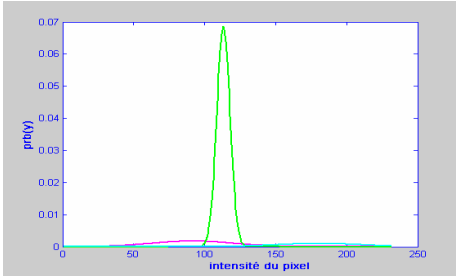

Fig. 2 Distributions likelihood density of each class

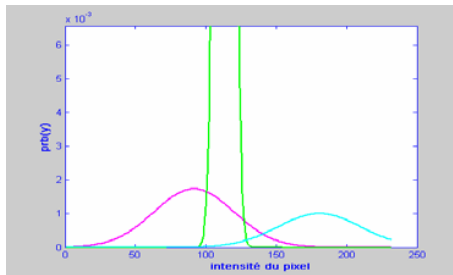

Fig. 3 Window from Fig. 2

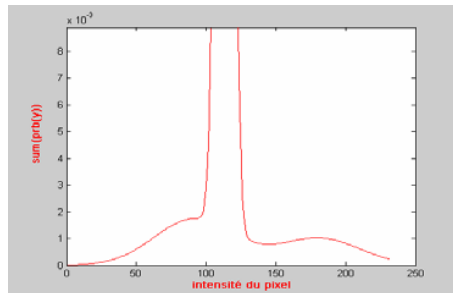

Fig. 4 Mixture of three Gaussian distribution

Estimated parameters by EM algorithm are given by the three equations below.

$$\mu_j^{[t+1]} = \left(\sum_{i=1}^N \alpha_{ij}^{[t]} y_i \right) / \left(\sum_{i=1}^N \alpha_{ij}^{[t]} \right) \quad (2)$$

$$p_j^{[t+1]} = \left(\sum_{i=1}^N \alpha_{ij}^{[t]} \right) / N \quad (3)$$

$$\sigma_j^{2[t+1]} = \left(\sum_{i=1}^N \alpha_{ij}^{[t]} (y_i - \mu_j^{[t+1]})^2 \right) / \left(\sum_{i=1}^N \alpha_{ij}^{[t]} \right) \quad (4)$$

Once the EM sequence was made, and let given the expectation of log-likelihood $L(\phi; x)$ expressed by (5) of mixture distribution taking on a count the distribution of missing data a_{ij} , knowing the observed data and current parameter's vector, the function Q is defined by expression (6):

$$L(\phi, x) = \sum_{i=1}^N \sum_{j=1}^J a_{ij} \left[\ln p_j + \ln f_j(y_i, \theta_j) \right] \quad (5)$$

$$Q(\phi; \phi^{[t]}) = \sum_{i=1}^N \sum_{j=1}^J \alpha_{ij}^{[t]} \left[\ln p_j + \ln f_j(y_i, \theta_j) \right] \quad (6)$$

Considering the monotonicity of likelihood, the value of Q at $t+1$ iteration is higher than the one at the t iteration. The stop condition of the algorithm must check the following inequality (7), where ε is to within 0.001:

$$Q(\phi^{[t+1]}; \phi^{[t]}) - Q(\phi; \phi^{[t]}) \geq \varepsilon \quad (7)$$

Membership's conditional likelihood of each color level to class k is given by:

$$\alpha_{ij}^{[t]} = \Pr(z_i = j | y_i, \phi) = \frac{p_j^{[t]} f_j(y_i, \theta_j^{[t]})}{\sum_{j=1}^J p_j^{[t]} f_j(y_i, \theta_j^{[t]})} \quad (8)$$

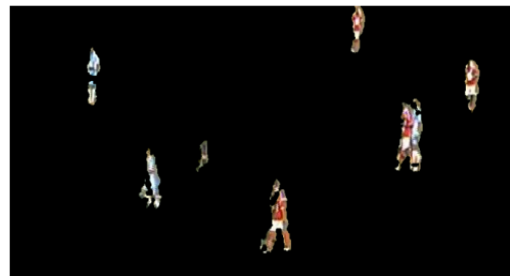

Fig. 5 Color image treatment and play field segmentation

IV. OVERVIEW ON SPORTING EVENTS

A. Introduction

This study regards the position of ball and its sense of direction (SDB) on one hand, the related parameters of various

players existing in playfield on the other hand, as the most important factor leading to describe the offensive/defensive situations and strategy coach's games. A soccer field is divided into three zones in this study and hence the ball should lie in one of them. The three zones are offensive zone, and defensive zone; which present the interesting zones in our approach (finishing zone), the other zone are formation zone (midfield zone). As it is define in soccer game, the offensive zone is near the opponent's goal and shooting is the major goal.

Similarly with semantic analysis in which the semantic representation is constructed from video content, we need to extract proper clues from video and construct an effective representation to discover the deep insight of the soccer game in the tactic context. As the team sports, the tactics used in the soccer game is characterized by the behavior of individual player (e.g. positions and velocities of the player in the field) and the interactions among players and ball (e.g. ball passing from one player to other player).

Movement's direction of players and ball can right reflect such characterization, in which we can locate players and analyze their mutual relationship.

B. Highlight Model and Architecture

In a soccer field, the current situation depends on many factors. For two n-player teams, the number of factor affecting the current situation can be estimated by the following equation:

$$N_f = (2n + 1) \tag{9}$$

where N_f is the number of affecting factors, it represents velocity and speed of the moving objects [26] vectors of two players (VA, VB); the item '1' represents the ball. Note that (1) does not consider accelerations of the ball and the players. Events indicate transitions from one stable state to the other: they capture relevant steps in the progression of the play.

In a soccer game, the two most important issues are to bring the ball into the opponent's goal and to prevent the ball from going into teammate's goal. As a concrete example, we consider the case of the duel situation between two players, the other players are omitted in this approach. Its description provided by a domain expert is as follows:

Player that has the ball tries to attract the opponent and then pass the ball towards the teammate player. He receives the ball again, dribbles progressively. The player prepares to pass the ball backwards, and tries to overtake the opponent without ball towards the finishing zone. Eventually, the ball is either blocked by the defender or ends to goalkeeper or goes beyond the field end line.

V. FUZZY SEQUENTIAL TECHNIQUE FOR EVENTS DISCRIMINATION

A. Relationship between Parameters and Events

Remind that the output of identification and tracking systems represented by both fuzzy models and models based on combination logic between the entries parameters depend

only that current values of input systems. In sequential system the output values depend not only by current input values but of their previously states, indeed such system take into a count a chronologic order of different sequences, relationships between inputs parameters and different events are enumerated as follows [27], the considered parameters (VA, VB) can keep up three values High (H), Low (L) and Medium (M), the (SDB) parameter can be Right Direction (Right.D) or Left Direction (Left.D).

- ① If (VA is Low) and (VB is Low) and (SDB is Right.D) then (Event is B.P)
- ② If (VA is Low) and (VB is Low) and (SDB is Left.D) then (Event is B.P)
- ③ If (VA is Medium) and (VB is Low) and (SDB is Left.D) then (Event is B.P)
- ④ If (VA is High) and (VB is Medium) and (SDB is Left.D) then (Event is Drb)
- ⑤ If (VA is High) and (VB is High) and (SDB is Right.D) then (Event is B.P)
- ⑥ If (VA is High) and (VB is High) and (SDB is Left.D) then (Event is Drb)
- ⑦ If (VA is Medium) and (VB is Low) and (SDB is Right.D) then (Event is B.I)

Fig. 6 Fuzzy sequential rules describing the considred events

The diagram explaining the relationships set between players in each event which are summarized by the transition graph as it is shown in Fig. 7.

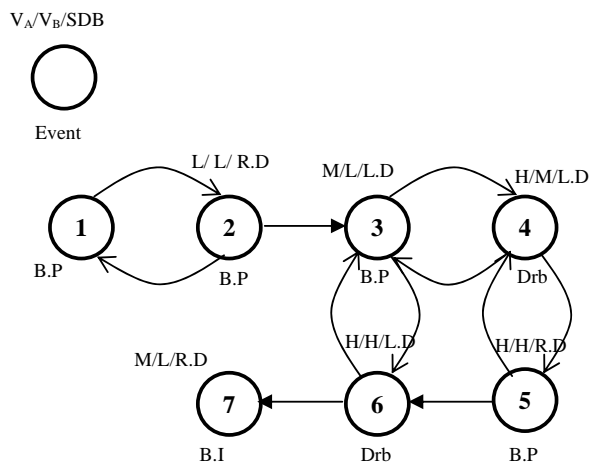

Fig. 7 Transition graph associated to described sporting events

B. Primitive Matrix

The primitive matrix expresses the transition graph as a table having as much lines as there are stable states and as much column as there are possible situation. Each line contains a stable state which is located in column having the same combination of input parameters.

Transitory state has the same number of stable state to which it evolves as it is illustrated in Table I. It is placed in the box which constitutes the intersection between previous stable state line on one hand, and next stable state column on other hand. The connections of transition graph are substituted by transitory states numbered and not circled. So there are as

much transitory states as there are connected in transition graph.

TABLE I
MATRIX OF STABLE AND TRANSITORY STATES

L/L/L	L/L/R/D	H/M/L/D	M/L/L/D	H/H/R/D	H/H/L/D	Event
1						B.P
1	2		3			B.P
		4	3		6	B.P
		4	3	5		Drb
		4		5	6	B.P
			3	7	6	Drb
				7		B.I

According the described sequence in section 4.2 and the primitive matrix, we can draw a fusion graph which will allow us to define the possible solution of the evolution of players' movement on going the game, which may be optimized again because the many redundant situation. The present situation can flow two chronological tracks as illustrated by Fig. 8.

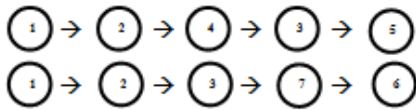

Fig. 8 Possible chronological tracks relative to this sequence

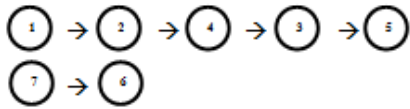

Fig. 9 Optimal solutions and suppression redundant situation

Eventually, according Fig. 9 we note that the primitive matrix is reduced on two lines after fusion phase as it is shown in Table II.

TABLE II
REDUCED PRIMITIVE MATRIX

L/L/L	L/L/R/D	H/M/L/D	M/L/L/D	H/H/R/D	H/H/L/D
1	2	4	3	5	6
-	-	-	3	7	6

C.Results of Event Discrimination and Method Interpretation

To describe different events according the parameters of each player and the necessary input which represent a feedback of previous event, we operate as follows:

- Stable states: represented by its three values given by transition graph or by table which describes the event states.
- Transitory states: they can take different values according the used technology.

Finally the considered events Ball possession (B.P), Dribbling (Drb) and Ball Interception (B.I), are described at a given time t by one expression according the inputs parameters.

In the future, we will apply our approach to other tasks, and criticize skills in a soccer game, such as 'shoot', 'block', 'pass', 'defensive phase', 'offensive phase' and 'receive', it would be very useful to analyze the trajectories of players to study the strategy of soccer games, and evaluate the performance of players in quantitative ways. Indeed our model, which is based on movements of players and ball, we can extract useful information to make strategies of soccer games. In particular, several performance measures will be introduced to analyze the performance concerning the interactions between the players of the same team and of adversary.

VI. CONCLUSION

In this paper, we propose a new spatio-temporal technique based on sequential process to describe and discriminate events of various players in sporting sequence based on historical and future movements of moving players, indeed the sequential technique seems more and more sophisticated in order to consider most of the important situations. All kinds of queries including past queries, future queries, and queries that start in the past and finish in the future are considered in our technique at the aim to enhance different motion of player, both to corresponding events such as Dribbling, Ball Possession, and Ball Interception on one hand and to quantitatively express the performance of soccer players since the described motion is related only to individual performance of a player on other hand. The player's events which are described were characterized by their velocity and the ball which produce their trajectories. For this reason, the direction of ball and velocity vector of players and their relationships gives useful information to discover strategies of team and clarify the contribution of each player to his team strategy.

REFERENCES

- [1] Y. Gong, T. Lim and H. Chua, "Automatic Parsing of TV Soccer Programs," in *IEEE International Conference on Multimedia Computing and Systems*, May 1995, pp. 167-174.
- [2] D. Yow, B.-L. Yeo, M. Yeung and B. Liu, "Analysis and Presentation of Soccer Highlights from Digital Video," in *Asian Conference on Computer Vision*, 1995.
- [3] V. Tovinkere and R.-J. Qian, "Detecting Semantic Events in Soccer Games: Towards a Complete Solution," in *IEEE Proceedings of ICME'01*, 2001, pp. 1040-1043.
- [4] D. Zhong and S.-F. Chang, "Structure Analysis of Sports Video Using Domain Models," in *IEEE International Conference on Multimedia and Expo*, August 2001.
- [5] Y. Wang, Z. Liu and J. Huang, "Multimedia Content Analysis Using Both Audio and Visual Clues," *IEEE Signal Processing Magazine* 17(6), pp. 12-36, 2000.

- [6] M. Han, W. Hua, W. Xu, and Y.-H. Gong, "An Integrated Baseball Digest System Using Maximum Entropy Method," *Proc. of ACM MM'02*, pp.347-350, (2002).
- [7] J. Assfalg, M. Bertini, C. Colombo and D. Bimbo, "A Semantic Annotation of Sports Videos," *IEEE Multi-Media*, vol.9, no.2, pp. 52-60, (2002).
- [8] N. Babaguchi, Y. Kawai, and T. Kitahashi, "Event Based Video Indexing by Intermodal Collaboration," *IEEE Transactions on Multimedia*, vol.4, no.1, pp. 68-75, (2002).
- [9] J.-R. Wang, and N. Paramesh, "A Scheme for Archiving and Browsing Tennis Video Clips," *Proc. Of IEEE Pacific-Rim Conf. on Multimedia (PCM'03)*, Singapore, (2003).
- [10] Y. Rui, A. Gupta and A. Acero, "Automatically Extracting Highlights for TV Baseball Programs," in *Proceedings of the ACM Multimedia Los Angeles, CA*, 2000.
- [11] Y. Gong, L.-T. Sin, C.-H. Chuan, H.-J. Zhang and M. Sakauchi, "Automatic Parsing of TV Soccer Programs," *IEEE Conf. Multimedia Systems Comput.*, 1995, pp. 167-174.
- [12] N. Babaguchi, Y. Kawai, and T. Kitahashi, "Event Based Indexing of Broadcast Sports Video by Intermodal Collaboration," *IEEE Trans. Multimedia*, 4(1), 2002.
- [13] S. Brakatsoulas, D. Pfoser and N. Tryfona, "Modeling, Storing and Mining Moving Object Databases," *Proceedings of the International Database Engineering and Application Symposium (IDEAS'04)*, 2004.
- [14] C.-H. Kang, J.-R. Hwang, and K.-J. Li, "Trajectory Analysis for Soccer Players," *Proc. Int. Conf. Data Mining Workshops*, 2006, pp. 377-381.
- [15] X. Yu, Ch. Xu, H.-W. Leong, Q. Tian, Q. Tang, and K.-W. Wan, "Trajectory-Based Ball Detection and Tracking with Applications to Semantic Analysis of Broadcast Soccer Video," in *Proceedings of the 11th ACM International Conference on Multimedia*, 2003, pp. 11-20.
- [16] P. Figueroa, N. Leite, and R. Barros, "Tracking Soccer Players Using the Graph Representation," in *Proceedings of the 17th International Conference on Pattern Recognition*, 2004, pp. 787-790.
- [17] L. Barcelacuteo, X. Binefa, and J.-R. Kenfer, "Robust Methods and Representations for Soccer Player Tracking and Collision Resolution," in *Proceedings of the 4th International Conference on Image and Video Retrieval*, 2005, pp. 237-246.
- [18] W.-T. Chu and W.-H. Tsai, "Modeling Spatiotemporal Relationships between Moving Objects for Event Tactics Analysis in Tennis Videos," *Multimedia Tools and Applications*, 50(1), pp. 149-171, 2010.
- [19] A. Ekin, A. Murat Tekalp, and R. Mehrotra, "Automatic Soccer Video Analysis and Summarization," *IEEE Transactions on Image Processing*, 12(7), pp. 796-807, 2003.
- [20] J.-R. Wang and N. Parameswaran, "Survey of Sports Video Analysis: Research Issues and Applications," in *VIP '05: Proceedings of the Pan-Sydney Area Workshop on Visual Information Processing*, Darlinghurst Australian Computer Society, Inc., 2004, pp. 87-90.
- [21] T. Taki, J. Hasegawa, and T. Fukumura, "Development of Motion Analysis System for Quantitative Evaluation of Teamwork in soccer game," in *IEEE International Conference on Image Processing*, 1996, pp. 815-818.
- [22] A. Fujimura and K. Sugihara, "Geometric Analysis and Quantitative Evaluation of Sport Teamwork," *Systems and Computers in Japan*, 36(6), pp. 49-58, 2005.
- [23] S.-L. Chin, Ch.-H. Huang, Ch.-T. Tang, and J.-C. Hung, "An Application Based On Spatial Relationship to Basketball Defensive Strategies," in *Proceedings of Embedded and Ubiquitous Computing Workshops*, Berlin/Heidelberg, Germany, Springer-Verlag 2005, pp. 180-188.
- [24] B. Krausz and R. Herpers, "Detecting Events in Subway Stations," *Multimedia Tools and Applications*, 50(1), pp. 123-147, 2010.
- [25] J.-L. Shih, Y.-N. Chen, K.-C. Yan and C.-C. Han, "Illegal Entrant Detection at a Restricted Area in Open Spaces Using Color Features," *Journal of Information Science and Engineering* 25, pp. 1575-1592, 2009.
- [26] K.-Ch. Vilas, M.-D. Darren, E.-D. Warren and J. Chen, "Identification of a Moving Object's Velocity with a Fixed Camera," *Automatica*, Elsevier, 41(2005), pp. 553-562, 2005.
- [27] D. Roth, E.-K. Meier and L.-V. Gool, "A New Spatio-Temporal Method for Event Detection and Personalized Retrieval of Sports Video," *Multimedia Tools and Applications*, 50(1), pp. 29-47, 2010.



Mourad Moussa was born in Ben Arous, Tunisia in 1977. He received the Master degree in Automatic from the "National Engineers School of Monastir" in 2006 and the Ph.D. degree in Electrical Engineering from the "National Engineers School of Sousse" in 2011. He is presently Assistant Professor in the National Engineers School of Sousse. His research is related to Automatic control, Image & Signal Processing, signal transmission and renewable energy.



Ali Douik was born in Tunis, Tunisia. He received the Master degree from the "Ecole Normale Supérieure de l'Enseignement Technique de Tunis" in 1990 and the Ph.D. degree in Electrical Engineering from the "Ecole Supérieure des Sciences et Technique de Tunis" in 1996. He is currently an associate professor in the "Ecole Nationale d'Ingénieurs de Monastir". His research is related to Automatic Control, robust control, evolutionary optimization control and Image Processing.



Hassani Messaoud was born in Mahdia, Tunisia. He received the Master degree from the "Ecole Normale Supérieure de l'Enseignement Technique de Tunis", in 1985 and the Ph.D. degree in Automatic Control from the "Ecole Centrale de Lille, France", in 1993. In 2001, he received the ability degree from the "Ecole Nationale d'Ingénieurs de Tunis". He is presently Professor in the "Ecole Nationale d'Ingénieurs de Monastir" and Director of the laboratory LRATSI. He has been the supervisor of several PhD thesis and is author or co-author of several Journal articles. His research is related to Automatic Control and Signal Processing.