

# Fuzzy Neuro Approach to Busbar Protection; Design and Implementation

M. R. Aghaebrahimi, H. Khorashadi Zadeh

**Abstract**—This paper presents a new approach for busbar protection with stable operation of current transformer during saturation, using fuzzy neuro and symmetrical components theory. This technique uses symmetrical components of current signals to learn the hidden relationship existing in the input patterns. Simulation studies are performed and the influence of changing system parameters such as inception fault and source impedance is studied. Details of the design procedure and the results of performance studies with the proposed relay are given in the paper. An analysis of the performance of the proposed technique during ct saturation conditions is presented. The performance of the technique was investigated for a variety of operating conditions and for several busbar configurations. Data generated by EMTDC simulations of model power systems were used in the investigations. The results indicate that the proposed technique is stable during ct saturation conditions.

**Keywords**—Busbar protection, fuzzy neuro, Ct saturation.

## I. INTRODUCTION

IN power system networks, a bus is a connection point for many generation, transmission, or load circuits. If a fault occurs on a bus, all circuits supplying the fault current must trip to isolate the fault. A bus fault may result in considerable loss of service and severe system disturbance. Station arrangements are often designed to minimize the number of circuits that must be opened for a bus fault [1–12]. As a result of improved continuity of energy supplies and flexibility of system operations, some power system stations use complex bus arrangements that increase demands for sophisticated bus protection schemes [13]. Protection zone selection must be highly discriminative, such that a bus relay operates only for a protection zone fault.

Protection of busbar demands high standards. Failure to trip on an internal fault, as well as false tripping of a busbar during load service, or in case of external fault, both have disastrous effects on the stability of power systems, and may even cause complete blackouts.

Slow fault clearing results additionally in extensive damage at the fault location as a consequence of the generally high concentration of short circuit power at station buses.

More than with other circuit protection methods, intensified emphasis is therefore put on the essential requirements of speed and stability.

A further important point to consider is through-fault stability with current transformer saturation.

This paper describes a technique that distinguishes faults in a busbar protection zone from those outside the zone. The technique is based on application of Fuzzy neuro as pattern classifier and symmetrical components as inputs fast and accurately. The phenomenon of ct saturation and its impact on the proposed technique has also been analyzed. Some test results are also presented. The proposed technique remains stable during ct saturation.

## II. BASIC STRUCTURE OF THE PURPOSED ALGORITHM

Figure 1 shows the block diagram of the proposed differential relay. Input signals are preprocessed by a 2nd-order low-pass Butterworth filter first. The anti-aliasing filters have a cut-off frequency of 400 Hz. The current samples are used as inputs of differential protection unit.

As shown, the structure consists of one FN unit. Also a logic unit is embedded into this structure to provide the appropriate tripping commands based on the output of the previous units. The inputs of FN unit consist of samples of the different sequence differential current. The outstanding feature of the proposed method with respect to the previous approaches, is the elimination of the ct saturation error of the relay and thereby the increase of the relay's sensitivity.

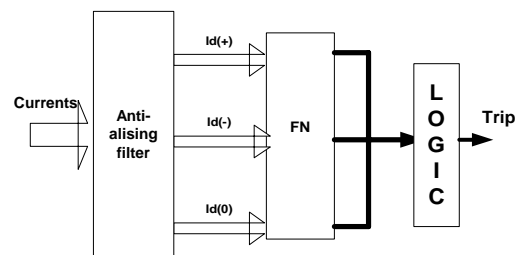

Fig. 1 Structure of the proposed differential relay

## III. SIMULATION OF THE POWER SYSTEM TO PREPARE THE PATTERN

Training patterns were generated by simulating different types of faults in a substation as shown in Fig. 2. The substation is of 230kV double busbar configuration and has eight different circuits operating. The simulation was done by means of EMTDC/PSCAD software package [14]. Current transformers have also been considered in the simulated system model for the study of the current transformer saturation problem. The modeled current transformer circuit diagram is shown in Fig. 3 and its parameters are given in Table 1.

Manuscript received Jan. 9, 2005.

M. R. Aghaebrahimi is with Department of Power Engineering, University of Birjand, Birjand, Iran. (Email: aghaebrahimi@bijand.ac.ir).

H. Khorashadi-Zadeh is with Department of Power Engineering, University of Birjand, Birjand, Iran. (Email: hkhoshadi@yahoo.com).

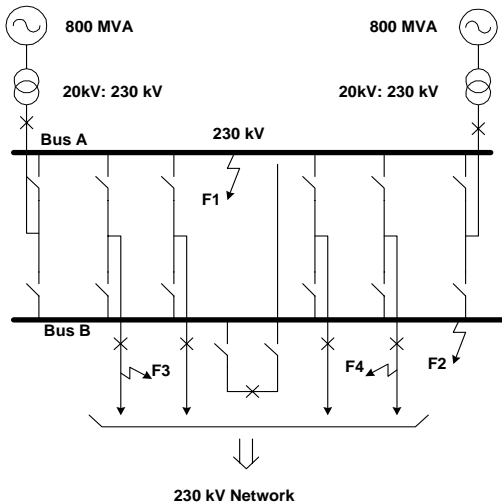

Fig. 2 230 kV double busbar

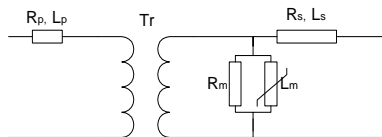

Fig. 3 Current transformer circuit diagram

TABLE I  
SIMULATED CURRENT TRANSFORMER PARAMETERS

Secondary winding resistance and leakage inductance ( $\Omega$ )	$0.5, 8 \times 10^{-4}$
Turn ratio	2000:1
Frequency (Hz)	50
Rated voltage (kV)	230

Training patterns were generated by simulating different types of faults on the power system. Fault type, fault location and fault inception time were changed to obtain training patterns covering a wide range of different power system conditions.

IV. FUZZY-NEURO TECHNIQUES

In this paper, the architecture of adaptive fuzzy network has been utilized. In general, fuzzy sets and neural networks deal efficiently with the two very distinct areas of information processing. Fuzzy sets are good at various aspects of uncertain knowledge representation, while fuzzy-neuro is an efficient structure capable of learning from examples. Both techniques have their advantages and disadvantages, and they can be complementary too [15].

Adaptive fuzzy network is inflected in three basic elements: fuzzification, fuzzy inference and defuzzification. In neural nets, the weights between the input and the first hidden layer as well as the last hidden layer and output layer, determine the input/output behavior. In a fuzzy system, these parameters are found in the fuzzification and defuzzification routines and can thus be trained. Calculated degrees of membership in the rule

layers are according to IF-THEN rules. The network uses the least-squares method and the back propagation gradient descent method to learn from the data sets, and find a suitable adaptive fuzzy network [16]. Fuzzy technologies map is shown in Fig. 4.

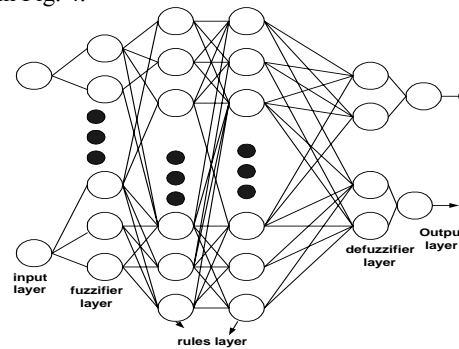

Fig. 4 Neuro fuzzy technologies map a neural net to a fuzzy neuro system

V. DESIGN OF THE FUZZY NEURO DIFFERENTIAL PROTECTION

The structure of the proposed scheme is shown in Fig. 5. It comprises of one pre-processing module and one fuzzy neuro module (the fuzzy neuro classifier).

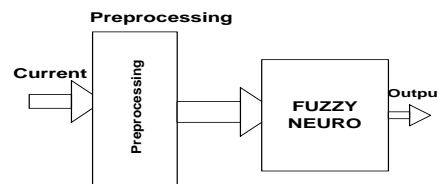

Fig. 5 The structure of the differential protection scheme

A. Training

An adaptive fuzzy network was chosen to process the input data set.  $Id1_{(+)} / I_n$ ,  $Id1_{(-)} / I_n$  and  $Id1_{(0)} / I_n$  are considered as input vector to the network. Where,  $Id1_{(+)}$ ,  $Id1_{(-)}$  and  $Id1_{(0)}$  are positive, negative and zero sequences of fundamental harmonic of differential current respectively and  $I_n$  is the nominal current. An output in final layer was chosen for the network. If an internal fault occurs, the detector output must be 1. Otherwise, it must be 0.

The training sets include data for different types of shunt faults, different fault location and fault inception angles at different condition of the system.

Membership functions and suitable fuzzy rules were obtained by the data sets that were obtained from the simulation. For training, Matlab software has been utilized.

As shown in Fig. 6, final membership functions of inputs are guessing function. Membership functions include three functions (low, medium and high). The FNN uses the least-squares method and the back propagation gradient descent method to learn from the data sets, and find a suitable adaptive fuzzy network.

Training fuzzy rules are shown in Table II. All the rules are derived from the training of the fuzzy-neuro model based on the prior database.

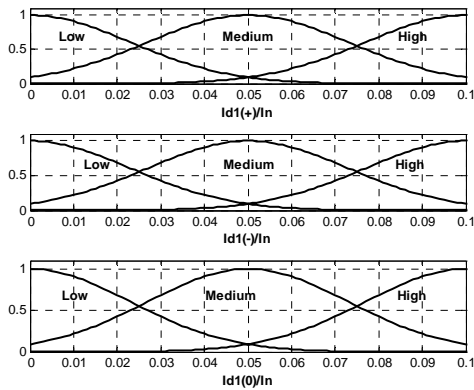

Fig. 6 Membership functions of the inputs of unit

Once trained, the FN performance was tested using test patterns that were different from the training patterns. Some of the simulation results are presented in the next section.

TABLE II  
FUZZY RULES

IF			THEN
$Id1_{(+)}/In$	$Id1_{(-)}/In$	$Id1_{(0)}/In$	Output
Low	Low	Low	No Trip
Low	High	High	No Trip
High	Low	Low	Trip
High	High	High	Trip
Medium	Low	Low	Trip
Medium	Low	Low	Trip
Medium	High	High	No Trip
Medium	Low	Low	Trip
Medium	High	High	Trip
Medium	Medium	Medium	No Trip
Medium	Medium	Medium	Trip
High	Medium	Medium	Trip
Low	Medium	Medium	No Trip
Medium	Medium	Medium	Trip

**B. Test Result**

A validation data set consisting of about 70 different fault types was generated using the power system model shown in Fig. 2. The validation set fault patterns were different than the fault patterns used to train the network. For different faults of the validation set, fault type, fault location and fault inception time were changed to investigate the effects of these factors on the performance of the proposed algorithm.

The proposed FN output for four faults with different system conditions is shown in Figs. 7-10. For first and second cases, a fault is applied to the system at 15 ms and the FN output is shown for the first 25 ms after the fault inception, which is of utmost interest.

The FN output for a single phase to ground fault CG, is shown in Fig. 7. The fault was an internal fault at Bus A. As shown in this figure, the FN is able to respond to the fault correctly in a timely fashion.

The next example tests the FN's performance for a fault at another location. Fig. 8 shows the output of the FN for a fault

BG at bus B. The ANN performs correctly and quite fast, as shown in this figure.

At next cases, an external fault is applied to the system at feeder 230kV and saturation occurs on at the Ct of this feeder and the FN output is shown for the first 250 ms after the fault inception, which is of utmost interest. As shown for these cases, the relay output remains stable for this fault, which is outside the protection zone.

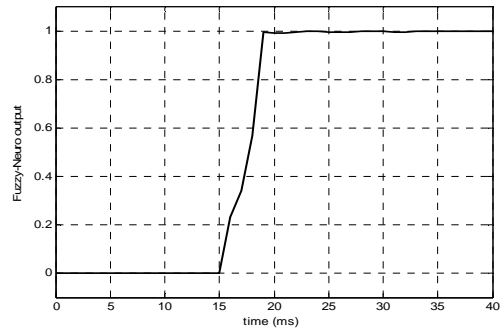

Fig. 7 FN output for CG fault at Bus A

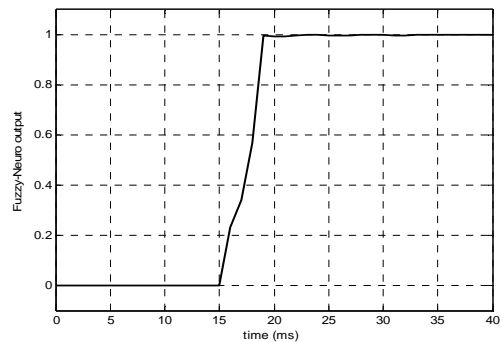

Fig. 8 FN output for BG fault at Bus B

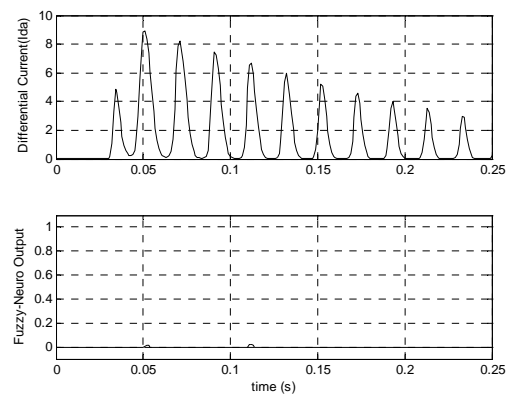

Fig. 9 FN output for AG external fault with ct saturation at Feeder 1

A validation data set consisting of about 70 different fault types were considered and the performance of the proposed algorithm was studied. From the obtained results, including the four cases shown, it could be concluded that this approach successfully the relay performs quite accurately and reliably. In general, the FN performs good and fast for more usual fault cases even for external faults with ct saturation.

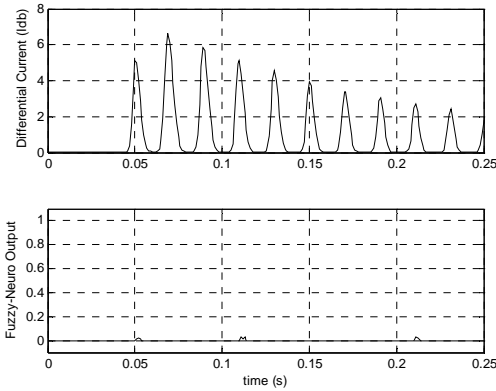

Fig. 10 FN output for BG external fault with ct saturation at Feeder 2

VI. IMPLEMENTATION OF FAULT CLASSIFIER

The proposed FN-based busbar protection was implemented on a Digital Signal Processor (DSP) board and its performance was evaluated. In this section, the hardware and software components required for real-time implementation of the proposed fault classifier are described. Details of the implementation along with the experimental studies are described as well.

A. Hardware System

Appropriate hardware consisting of three cards, namely; minimum system card, Data Acquisition System (DAS) card and Input/Output (I/O) card has been designed to implement the proposed FN-based algorithm. Hardware configuration of the implemented fault classifier is shown in Figure 11.

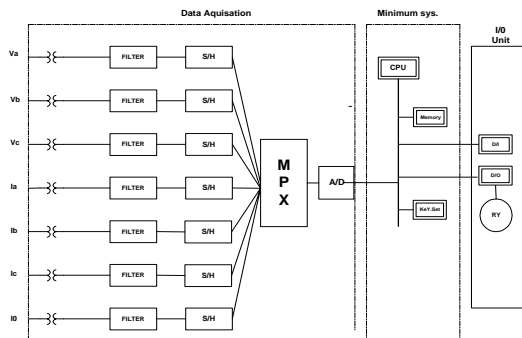

Fig. 11 Hardware configuration of the implemented fault detector

The architecture of the minimum system card is depicted in Figure 12. This card, based on a 50 MHz TMS320C25 digital

signal processor from Texas Instrument [17], is used as a digital signal processor card. This card controls the data-acquisition process. It also processes the acquired signals and implements the proposed technique. As shown in Fig. 12, this card includes a 32 Kword EPROM and an 8 Kword EEPROM. The designed DSP card includes other features such as Watch-Dog Timer, Keypad and LCD as well.

Appropriate hardware and software setup for accomplishing data acquisition were designed and fabricated. Active low-pass filters, sample holders, an analog multiplexer and an Analog to Digital (A/D) converter are furnished for sampling and analog-to-digital conversion of the instantaneous voltage and current data. The prepared digital data is then introduced to the minimum system card.

The sampling frequency  $f_s$  used in this work is 1 kHz. To attenuate high frequency components, an array of low-pass filters is used. Designed low-pass filters attenuate 400 Hz component to  $-20$  dB to restrain influence of aliasing and high frequency noise as much as possible. The resolution of the A/D converter is chosen as 12 bits including the sign bit and it has a fast conversion time.

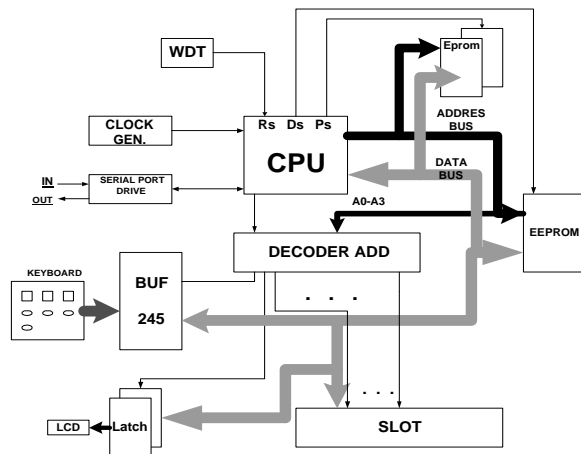

Fig. 12 Configuration of the minimum system card

B. Software System

Three software packages are required for implementing the prototype relay. These packages include data-acquisition, relaying and user-interface software, all of which have been developed appropriately.

The data-acquisition routine controls a sampling rate timer and acquires samples at successive sampling instances. It consists of two routines: a main routine and an interrupt service routine. The main routine initializes the system cards and sets the timer to achieve a sampling rate of 1000 Hz. Interrupt service routine executes functions related to data-acquisition such as sample and hold, analog to digital conversion and the execution of the relaying software.

An executable code of the relaying software has been generated using TMS320 fixed point C compiler and then is loaded into the DSP memory. Quantized samples obtained from DAS are used by this code to execute the proposed relaying technique. Appropriate programming language has been used to develop the relaying software. The relaying

software includes FN function. The FN function carries out the computations explained in the previous sections.

A graphical user interface software developed in visual C, uploads the obtained results from the DSP memory. The designed relay settings could also be changed using this interface. The setting program runs in parallel with the main program and changes the set values immediately according to the operator's request.

In addition, the man-machine interface of the designed relay provides the following status information:

1. Key buttons for relaying element selection
2. Four keys for value setting
3. Buttons value displays
4. Setting value displays
5. Relay operation displays
6. Hardware failure alarms

### C. Real-Time Test

The performance of the proposed FN-based relay has been verified in real-time using the data obtained through simulating various faults on a 230kV power system depicted in Fig. 1. The test data is obtained for different power system operation conditions and various types of faults at different locations. Computer simulations are performed using EMTDC/PSCAD software package and the obtained data is sent to the designed Fault detector hardware through the computer's parallel port and an interface circuit. The prepared data received by the designed hardware is processed and appropriate decision is made based on the designed Fault detector characteristics. The results prove that the proposed detector can easily detect different fault types under different conditions as well.

## VII. CONCLUSIONS

Fuzzy neuro capabilities in pattern recognition and classification are used and a fuzzy neuro differential relay is designed for busbar protection. The relay, meant for discriminating faults in a bus-protection zone from those outside the zone has been presented in this paper. The proposed neuro-fuzzy scheme has been implemented on a digital signal processor board. Simulation studies are performed and the relay's performance with different system parameters and conditions is investigated. The proposed relay is stable during ct saturation. The Performance studies results confirm that the proposed algorithm is fast and accurate.

## REFERENCES

- [1] F. Andow, N. Suga, Y. Murakami, and K. Inamura, "Microprocessor based busbar protection relay," in 5th Int. Conf. on Developments in Power System Protection, 1993, IEE Pub. no. 368, pp. 103-106.
- [2] J. B. Royle and A. Hill, "Low impedance biased differential busbar protection for application to busbars of widely differing configurations," in 4th Int. Conf. on Developments in Power System Protection, 1989, IEE Pub. no. 302, pp. 40-44.
- [3] D. M. Peck, B. Nygaard, and K. Wadelius, "A new numerical busbar protection system with bay oriented structure," in 5th Int. Conf. On Developments in Power System Protection, 1993, IEE Pub. no. 368, pp. 228-231.
- [4] A. Kumar and P. Hansen, "Digital bus-zone protection," IEEE Computer Applications in Power, vol. 6, no. 4, pp. 29-34, 1993.
- [5] T. Forfordand and J. R. Linders, "A half-cycle bus differential relay and its application," in IEEE PES Winter Meeting, New York, NY, Jan. 27-Feb. 1, 1974, pp. 1110-1120.
- [6] Brewis, K.; Hearfield, K.; Chapman, K., "Theory and practical performance of interlocked overcurrent busbar zone protection in distribution substations", Developments in Power System Protection, 2001, Seventh International Conference on (IEE) , 9-12 April 2001 pp. 475 - 478.
- [7] Watanabe, H., Shuto, I., Igarashi, K., Beaumont, P., Okuno, K., "An enhanced decentralised numerical busbar protection relay utilising instantaneous current values from high speed sampling" Developments in Power System Protection, 2001, Seventh International Conference on (IEE) , 9-12 April 2001 pp. 133 - 136.
- [8] Kasztenny, B., Cardenas, J., "New phase-segregated digital busbar protection solutions" Protective Relay Engineers, 2004 57th Annual Conference for , 30 Mar-1 Apr 2004 pp. 308 - 338.
- [9] Jiang, F., Bo, Z.Q., Redfern, M.A., Weller, G., Chen, Z., Dong Xinzhou, "Application of wavelet transform in transient protection-case study: busbar protection" Developments in Power System Protection, 2001, Seventh International Conference on (IEE) , 9-12 April 2001 pp. 197 - 200.
- [10] Sachdev, M.S, Sidhu, T.S., Gill, H.S., "A busbar protection technique and its performance during CT saturation and CT ratio-mismatch" Power Delivery, IEEE Transactions on , Volume: 15 , Issue: 3 , July 2000 pp. 895 - 901.
- [11] Kasztenny, B., Kuras, K., "A new algorithm for digital low-impedance protection of busbars" Power Engineering Society Summer Meeting, 2001. IEEE , Vol. 1 , 15-19 July 2001 pp. 97 - 102.
- [12] Kang, Y.C., Kang, S.H., Crossley, P.A., "Design, evaluation and implementation of a busbar differential protection relay immune to the effects of current transformer saturation" Generation, Transmission and Distribution, IEE Proceedings- , Vol. 151 , Issue: 3 , May 2004.
- [13] Elmore, W.A., "Some observations on bus relaying" Protective Relay Engineers, 2004 57th Annual Conference for , 30 Mar-1 Apr 2004, pp. 30 - 45.
- [14] PSCAD/EMTDC User's Manual, Manitoba HVDC Research Center, Winnipeg, Manitoba, Canada.
- [15] Lee, C. C., 'Fuzzy Logic in Control System: Fuzzy Logic controller-part I', IEEE Transmission on System, Man. and Cybernetics, Vol. 20, No.2, 1 April 1990, pp. 404-418.
- [16] Ichihashi, H., "Learning in Hierarchical Fuzzy models by conjugate gradient Method using Backpropagation Errors" Proc. Of Intelligent System Symp., pp.235-240, 1991.
- [17] TMS320C25-User's Guide, Texas' Instruments, Houston, Tx.

**Aghaebrahimi, M. R.** received his B.Eng. in electrical engineering from Mashhad Ferdowsi University, Mashhad, Iran, in 1989. He received his M.Sc. and Ph.D. degrees from University of Manitoba, Canada, in 1993 and 1997, respectively. His areas of interest include power system digital simulation, HVDC transmission systems and electric machines. Currently, he is an Assistant Professor at the Department of Power Engineering, University of Birjand, Birjand, Iran.

**Khorashadi-Zadeh, H.** received his B.Eng. in electrical engineering from Mashhad Ferdowsi University, Mashhad, Iran, in 1998, and his M. Sc. from University of Tehran, Tehran, Iran, in 2000. His areas of interest include high voltage substation design, power system protection, digital relays and application of AI. Currently, he is a Lecturer/Instructor at the Department of Power Engineering, University of Birjand, Birjand, Iran.