

Fingerprint Compression Using Contourlet Transform and Multistage Vector Quantization

S. Esakkirajan, T. Veerakumar, V. Senthil Murugan and R. Sudhakar

Abstract—This paper presents a new fingerprint coding technique based on contourlet transform and multistage vector quantization. Wavelets have shown their ability in representing natural images that contain smooth areas separated with edges. However, wavelets cannot efficiently take advantage of the fact that the edges usually found in fingerprints are smooth curves. This issue is addressed by directional transforms, known as contourlets, which have the property of preserving edges. The contourlet transform is a new extension to the wavelet transform in two dimensions using nonseparable and directional filter banks. The computation and storage requirements are the major difficulty in implementing a vector quantizer. In the full-search algorithm, the computation and storage complexity is an exponential function of the number of bits used in quantizing each frame of spectral information. The storage requirement in multistage vector quantization is less when compared to full search vector quantization. The coefficients of contourlet transform are quantized by multistage vector quantization. The quantized coefficients are encoded by Huffman coding. The results obtained are tabulated and compared with the existing wavelet based ones.

Keywords—Contourlet Transform, Directional Filter bank, Laplacian Pyramid, Multistage Vector Quantization

I. INTRODUCTION

FINGERPRINTS are the ridge and furrow patterns on the tip of the finger and are used for personal identification of the people [1]. Federal Bureau of Investigation (FBI) deals with a massive collection of fingerprint cards, which contains more than 200 million cards and is growing at a rate of 30,000 - 50,000 new cards per day [2]. FBI is digitizing these cards to allow for electronic storage, retrieval, and transmission. Fingerprints are digitized at a resolution of 500 pixels/inch with 256 gray levels. A single fingerprint is about

700,000 pixels and needs about 0.6 Mbytes to store. A pair of hands then requires about 6 Mbytes of storage. So digitizing the FBI's current archive would result in more than 200 Terabytes of data. Because of data storage requirements and the time needed to send a fingerprint card over a modem, these files must be compressed. Although there are many image compression techniques currently available, there still exists a need to develop faster and more robust algorithms adapted to fingerprints. The currently used fingerprint standard is based on the discrete wavelet transform [3] using the biorthogonal wavelet 7.9. Although the performance of this standard is better than that of the cosine transform based JPEG standard, it still needs enhancements. To achieve better quality, i.e., high peak signal to noise ratio (PSNR) contourlet transform [4] and multistage vector quantization (MSVQ) [5] are considered in this work.

Compression can be achieved by transforming the data, quantizing the coefficients obtained during transformation and then encoding the quantized coefficients. To avoid redundancy, which hinders compression, the transform must be at least biorthogonal and in order to save CPU time, the corresponding algorithm must be fast [6]. The two-dimensional wavelet transform satisfies these conditions. Wavelet compression allows the integration of various compression techniques into one algorithm. Recently there has been a wide interest in image representations that efficiently handle geometric structure. One such representation is contourlet transform. The contourlet transform is proposed as a mean to fix the failure of wavelets in handling geometry by the presence of directional vanishing moments in the contourlet frame element. Vector quantization (VQ) is a quantization technique [7] applied to an ordered set of symbols. The superiority of 'VQ' lies in the block coding gain, the flexibility in partitioning the vector space, and the ability to exploit intra-vector correlations. MSVQ divides the encoding task into several stages. The first stage performs a relatively crude encoding of the input vector using a small codebook. Then, the second stage quantizer operates on the error vector between the original vector and the quantized first stage output. The quantized error vector provides a refinement to the first approximation. The indices obtained by multistage vector quantizer are then encoded using Huffman coding.

The remainder of the paper is organized as follows: Section II focuses on contourlet transform, Section III emphasizes on multistage vector quantization, Section IV deals with the proposed image compression scheme and finally conclusions

Manuscript received July 3, 2006.

S. Esakkirajan is working as a Lecturer, in the Department of Electrical and Electronics Engineering, PSG College of Technology, Peelamedu, Coimbatore-641 004, Tamilnadu, India. (Corresponding author to provide phone: 91-422-2572177; e-mail: rajanesakki@yahoo.com).

T. Veerakumar is working as a Lecturer, in the Department of Electronics and Communication Engineering, PSG College of Technology, Peelamedu, Coimbatore-641 004, Tamilnadu, India. (e-mail: tveerakumar@yahoo.co.in).

V. Senthil Murugan is with Cognizant Technology Solution, Chennai, India. (e-mail: senthilmurugan_eee@yahoo.co.in).

R. Sudhakar is working as a Lecturer, in the Department of Electronics and Communication Engineering, PSG College of Technology, Peelamedu, Coimbatore-641 004, Tamilnadu, India. (e-mail: sudha_radha2000@yahoo.co.in).

are drawn in Section V.

II. CONTOURLET TRANSFORM

The Contourlet Transform is a directional transform, which is capable of capturing contours and fine details in images. The contourlet expansion is composed of basis function oriented at various directions in multiple scales, with flexible aspect ratios. With this rich set of basis functions, the contourlet transform effectively capture smooth contours that are the dominant feature in natural images. In contourlet transform, the Laplacian pyramid does the decomposition of images into subbands and then the directional filter banks analyze each detail image as illustrated in Fig .1.

The pyramidal directional filter bank (PDFB) [8], was proposed by MinhDo and Vetterli, which overcomes the block-based approach of curvelet transform by a directional filter bank, applied on the whole scale also known as contourlet transform (CT). The grouping of wavelet coefficients suggests that one can obtain a sparse image expansion by first applying a multi-scale transform and then applying a local directional transform to gather the nearby basis functions at the same scale into linear structures. In essence, first a wavelet-like transform is used for edge (points) detection, and then a local directional transform for contour segments detection. With this insight, one can construct a double filter bank structure (Fig.2 (a)) in which at first the Laplacian pyramid (LP) is used to capture the point discontinuities, and followed by a directional filter bank (DFB) to link point discontinuities into linear structures [9]. The overall result is an image expansion with basis images as contour segments, and thus it is named the contourlet transform. The combination of this double filter bank is named pyramidal directional filter bank (PDFB).

Fig. 2(a) shows the block diagram of a PDFB. First a standard multi-scale decomposition into octave bands is computed, where the low pass channel is sub-sampled while the high pass is not. Then a directional decomposition with a DFB is applied to each high pass channel. Fig. 2(b) shows the support shapes for contourlets implemented by a PDFB that satisfies the anisotropy scaling relation. From the upper line to the lower line, four reduces the scale while the number of directions is doubled. PDFB allows for different number of directions at each scale/resolution to nearly achieve critical sampling. As DFB is designed to capture high frequency components (representing directionality), the LP part of the PDFB permits subband decomposition to avoid "leaking" of low frequencies into several directional subbands, thus directional information can be captured efficiently.

In general, the contourlet construction allows for any number of DFB decomposition levels 'l_j' to be applied at each LP level 'j'. For the contourlet transform to satisfy the anisotropy scaling relation, one simply needs to impose that in the PDFB, the number of directions is doubled at every other finer scale of the pyramid. Fig. 2(b) graphically depicts the supports of the basis functions generated by such a PDFB.

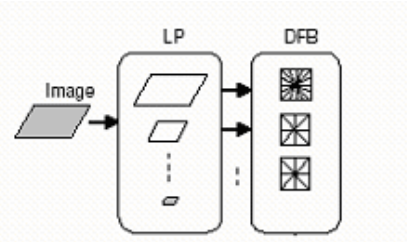

Fig. 1 A flow graph of the Contourlet Transform

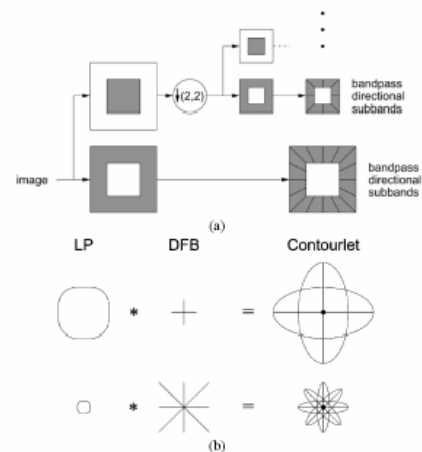

Fig. 2 (a) Block diagram of a PDFB, and (b) Supports for Contourlets

As can be seen from the two shown pyramidal levels, the support size of the LP is reduced by four times while the number of directions of the DFB is doubled. Combine these two steps, the support size of the PDFB basis functions are changed from one level to next in accordance with the curve scaling relation. In this contourlet scheme, each generation doubles the spatial resolution as well as the angular resolution.

The PDFB provides a frame expansion for images with frame elements like contour segments, and thus is also called the contourlet transform.

A. Laplacian Pyramid

One way of achieving a multiscale decomposition is to use a Laplacian pyramid (LP), introduced by Burt and Adelson [10].

The LP decomposition at each level generates a down sampled low pass version of the original and the difference between the original and the prediction, resulting in a bandpass image as shown in Fig. 3(a). In this figure, 'H' and 'G' are called analysis and synthesis filters and 'M' is the sampling matrix. The process can be iterated on the coarse version. In Fig. 3(a) the outputs are a coarse approximation 'a' and a difference 'b' between the original signal and the prediction. The process can be iterated by decomposing the coarse version repeatedly. The original image is convolved with a Gaussian kernel [11]. The resulting image is a low pass

filtered version of the original image. The Laplacian is then computed as the difference between the original image and the low pass filtered image. This process is continued to obtain a set of band-pass filtered images (since each one is the difference between two levels of the Gaussian pyramid). Thus the Laplacian pyramid is a set of band pass filters. By repeating these steps several times a sequence of images, are obtained. If these images are stacked one above another, the result is a tapering pyramid data structure, as shown in Fig. 4 and hence the name. The Laplacian pyramid can thus be used to represent images as a series of band-pass filtered images, each sampled at successively sparser densities. It is frequently

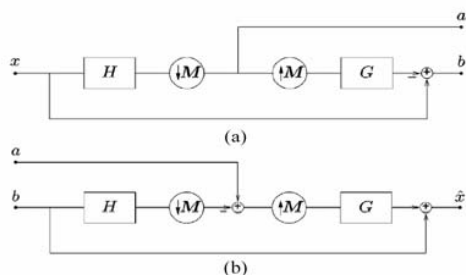

Fig. 3 Laplacian pyramid scheme (a) analysis, and (b) reconstruction

used in image processing and pattern recognition tasks because of its ease of computation. A drawback of the LP is the implicit oversampling. However, in contrast to the critically sampled wavelet scheme, the LP has the distinguishing feature that each pyramid level generates only one bandpass image (even for multi-dimensional cases), which does not have "scrambled" frequencies. This frequency scrambling happens in the wavelet filter bank when a high pass channel, after downsampling, is folded back into the low frequency band, and thus its spectrum is reflected. In the LP, this effect is avoided by downsampling the low pass channel only.

B. Directional Filter Bank

In 1992, Bamberger and Smith [12] introduced a 2-D directional filter bank (DFB) that can be maximally decimated while achieving perfect reconstruction. The directional filter bank is a critically sampled filter bank that can decompose images into any power of two's number of directions. The DFB is efficiently implemented via a l -level treestructured decomposition that leads to 2^l subbands with wedge-shaped frequency partition as shown in Fig. 5. The original construction of the DFB involves modulating the input signal and using diamond-shaped filters. Furthermore, to obtain the desired frequency partition, an involved tree expanding rule has to be followed. As a result, the frequency regions for the resulting subbands do not follow a simple ordering as shown in Fig. 4 based on the channel indices. The DFB is designed to capture the high frequency components (representing directionality) of images. Therefore, low frequency components are handled poorly by the DFB. In fact, with the

frequency partition shown in Fig. 5, low frequencies would leak into several directional subbands, hence DFB does not provide a sparse representation for images. To improve the situation, low frequencies should be removed before the DFB. This provides another reason to combine the DFB with a multiresolution scheme. Therefore, the LP permits further subband decomposition to be applied on its bandpass images. Those bandpass images can be fed into a DFB so that directional information can be captured efficiently. The scheme can be iterated repeatedly on the coarse image. The end result is a double iterated filter bank structure, named pyramidal directional filter bank (PDFB), which decomposes images into directional subbands at multiple scales. The scheme is flexible since it allows for a different number of directions at each scale. Fig. 6 shows the contourlet transform of the Fingerprint. Each image is decomposed into a low pass subband and several bandpass directional subbands. It can be seen that only contourlets that match with both location and direction of image contours produce significant coefficients. Thus, the contourlet transform effectively explores the fact, that the edges in images are localized in both location and direction.

One can decompose each scale into any arbitrary power of two's number of directions, and different scales can be decomposed into different numbers of directions. This feature makes contourlets a unique transform that can achieve a high level of flexibility in decomposition while being close to critically sampled. Other multiscale directional transforms

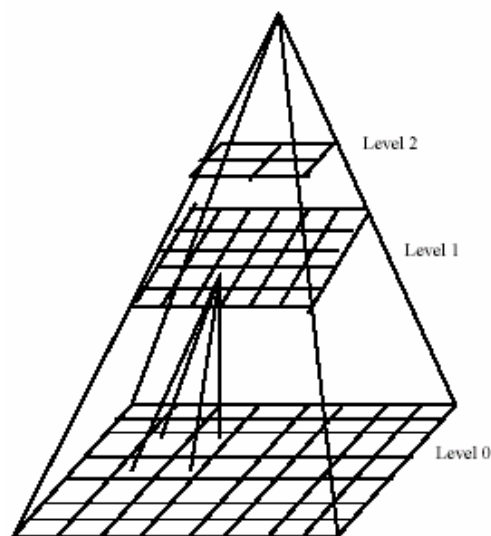

Fig. 4 Laplacian pyramid structure

either have a fixed number of directions or are significantly over complete.

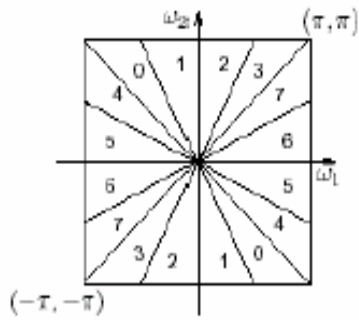

Fig. 5 DFB frequency partitioning

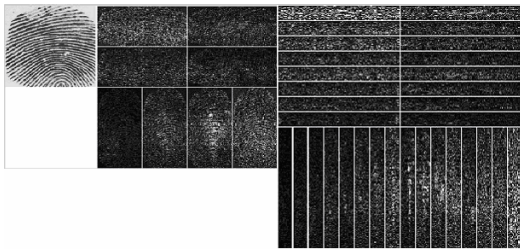

Fig. 6 Contourlet Transform of Fingerprint

III. MULTISTAGE VECTOR QUANTIZATION

In vector quantization, an input vector of signal samples is quantized by selecting the best matching representation from a codebook of 2^{kr} stored code vectors of dimension k . VQ is an optimal coding technique in the sense that all other methods of coding a random vector in k dimension with a specific number $b=kr$ of bits are equivalent to special cases of VQ with generally sub optimal codebooks. However, optimal VQ assumes single and possibly very large codebook with no imposed constraints in its structure. The resulting encoding and storage complexity, of the order of 2^{kr} , may be prohibitive for many applications. A structured VQ scheme which can achieve very low encoding and storage complexity is MSVQ. In MSVQ, the kr bits are divided between L stages with b_i bits for stage i . The storage complexity of MSVQ is

$$\sum_{i=1}^L 2^{b_i} \text{ vectors that can be much less than the complexity of}$$

$$\prod_{i=1}^L 2^{b_i} = 2^{kr} \text{ vectors for unstructured VQ. MSVQ [13] is a}$$

sequential quantization operation where each stage quantizes the residual of the previous stage.

The structure of MSVQ encoder [14] consists of a cascade of VQ stages as shown in fig. 7. For an L -stage MSVQ, a l^{th} stage quantizer $Q_l, l=0,1,2,...,L-1$ is associated with a stage codebook C_l contains K_l stage code vectors. The set of stage quantizers $\{Q_0, Q_1, \dots, Q_{L-1}\}$ are equivalent to a single quantizer Q , which is referred to as the direct-sum vector quantizer.

A. MSVQ Encoder

In the MSVQ encoder as shown in fig.7, the input vector 'X' is quantized with the first stage codebook producing the first stage code vector $Q_0(X)$, a residual vector y_0 is formed by subtracting $Q_0(X)$ from 'X'. Then y_0 is quantized using the second stage codebook, with exactly the same procedure as in the first stage, but with y_0 instead of X as the input to be quantized. Thus, in each stage except the last stage, a residual vector is generated and passed to the next stage to be quantized independently of the other stages.

MSVQ is an error refinement scheme, inputs to a stage are residual vectors from previous stage and they tend to be less and less correlated as the process proceeds.

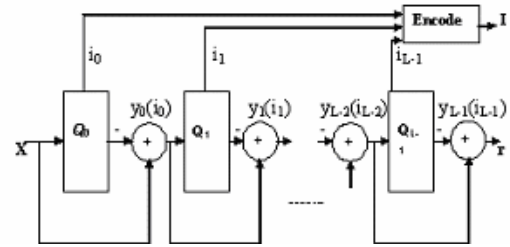

Fig. 7 Encoder block diagram of MSVQ

B. MSVQ Decoder

The decoder as shown in Fig. 8 receives for each stage an index identifying the stage code vector selected and forms the reproduction 'X' by summing the identified vectors. The overall quantization error is equal to the quantization residual

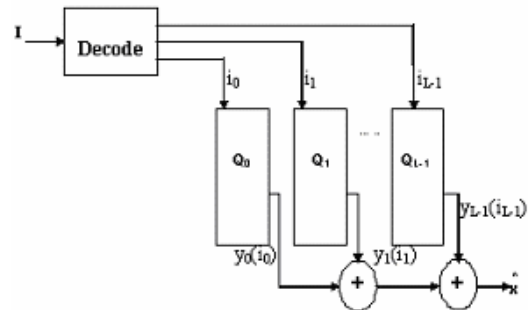

Fig. 8 Decoder block diagram of MSVQ

from the last stage. Sequential searching of the stage codebooks renders the encoding complexity to the storage

$$\text{complexity } \sum_{i=1}^L 2^{b_i} .$$

IV. PROPOSED SCHEME

The proposed algorithm is summarized below.

1. To decorrelate the relationship between pixels, contourlet transform is applied first to all the fingerprints taken. Different directional and pyramidal filter banks are considered for

decomposition. This is the initialization stage of the proposed algorithm.

2. Group neighboring contourlet coefficients into one vector.
2 by 2 contourlet coefficients are grouped into a vector.
3. Take the absolute values of all vector components since signs and absolute values of vector components are encoded separately in our algorithm, we consider only the magnitude of each vector component in the refinement process.
4. Find the training vectors for the first layer codebook. This can be done by two different ways. One is to include all training vectors of the first layer, i.e., symbols with norms larger than the first threshold T_1 . Another is to manipulate the components of vectors, e.g. multiplied by 2 or 4, so that all the vectors fall in the subspace of the first layer. The latter approach contains a much larger training set and richer patterns than the former one. We choose the second method in our coding scheme.
5. Perform multistage codebook training. The codebook training includes: find the centroids of the training set, and the residual code words of the first stage, second stage, and etc. The training method is Lloyd-Max iteration, which is often referred to as Linde, Buzo and Gray (LBG) [15]. In this work we do not design a different codebook for each individual layer. The same codebook is applied to all layers.
6. The indices obtained from Multistage Vector Quantization are encoded by Huffman coding.

The proposed scheme uses static Huffman coding where the same Huffman table is used for different fingerprints. This way overhead of sending Huffman tables along with coded data is eliminated.

V. RESULTS AND DISCUSSIONS

We present the encoding results of three different types of fingerprints [16] namely, Arch, Whorl and Tented arch [17]. For simplicity, we have considered only two stages in the multistage vector quantization. The same algorithm can be extended to many stages. As a trial we have tested our algorithm by including three stages in MSVQ for ‘whorl’ type fingerprint. We found that there is an improvement in the quality of the reconstructed image at the expense of execution time. The codes are run on a Pentium IV PC with 256Mb RAM.

Table I gives the result of the proposed scheme against wavelet based MSVQ for ‘Arch’ type Fingerprint and the corresponding plot is shown in Fig. 9. In Table I P-filter stands for Pyramidal filer and D-filter stands for Directional filter. From the Table I, we can infer that the proposed scheme outperforms the wavelet based multistage vector quantization. In the case of fingerprint image, the ‘Haar’ and ‘9-7’ as the pyramidal and directional filter combination gives better PSNR result when compared to other pyramidal and

TABLE I
PSNR VALUES FOR WAVELET VS CONTOURLET TRANSFORM FOR ARCH TYPE FINGERPRINT

Bpd Filters	0.125	0.25	0.5	0.75	1.0
Wavelet: ‘Haar’	25.8820	38.7565	50.5928	54.3465	59.9010
Contourlet:					
P-filter: ‘Haar’ D-filter: ‘9-7’	27.7315	40.1037	51.9884	55.5676	62.6486
P-filter: ‘Haar’ D-filter: ‘pkva’	27.7584	40.0999	51.9807	55.5614	62.6456
P-filter: ‘Haar’ D-filter: ‘5-3’	26.4390	39.3212	51.3174	54.8794	62.1502
P-filter: ‘9-7’ D-filter: ‘pkva’	21.6754	28.4383	35.1472	38.7381	41.2961
P-filter: ‘pkva’ D-filter: ‘9-7’	21.1154	27.8619	34.3806	37.8090	40.1303
P-filter: ‘5-3’ D-filter: ‘9-7’	22.8744	30.1356	31.9153	35.1001	37.3613
P-filter: ‘9-7’ D-filter: ‘5-3’	21.4573	28.3826	35.1316	38.7230	41.2917
P-filter: ‘pkva’ D-filter: ‘5-3’	21.1001	27.8567	34.3795	37.8072	40.1301
P-filter: ‘5-3’ D-filter: ‘pkva’	22.8840	30.1386	31.9156	35.1000	37.3612

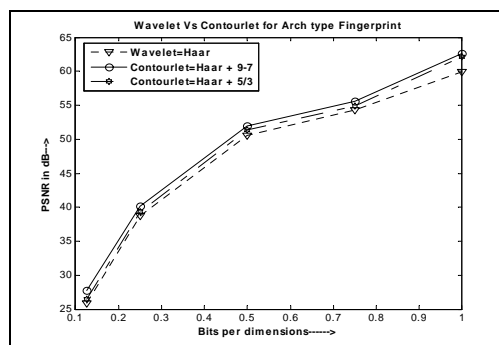

Fig. 9 Plot of PSNR Vs bit rate for Arch type fingerprint

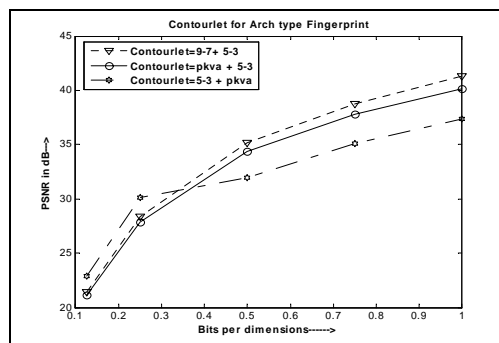

Fig. 10 Comparison of bit rate Vs PSNR between different pyramid and directional filters for Arch type Fingerprint

TABLE II
PSNR VALUES FOR WAVELET VS CONTOURLET TRANSFORM FOR WHORL TYPE FINGERPRINT

Bpd Filters	0.125	0.25	0.5	0.75	1.0
Wavelet: 'Haar'	27.1424	39.3130	51.0576	54.8483	60.6549
Contourlet:					
P-filter: 'Haar' D-filter: '9-7'	27.8948	40.0786	52.0603	55.6817	62.5094
P-filter: 'Haar' D-filter: 'pkva'	27.8981	40.0896	52.0582	55.6769	62.5085
P-filter: 'Haar' D-filter: '5-3'	27.8117	39.9904	51.9785	55.6013	62.4465
P-filter: '9-7' D-filter: 'pkva'	27.9788	40.2739	52.3538	55.7253	64.2610
P-filter: 'pkva' D-filter: '9-7'	27.2947	39.4134	51.5580	54.9343	63.6097
P-filter: '5-3' D-filter: '9-7'	29.7069	42.0123	54.0421	57.5380	66.1097
P-filter: '9-7' D-filter: '5-3'	27.8618	40.1528	52.2465	55.6317	64.1534
P-filter: 'pkva' D-filter: '5-3'	27.2290	39.3447	51.4852	54.8762	63.5566
P-filter: '5-3' D-filter: 'pkva'	29.7444	42.0062	54.0574	57.5604	66.1263

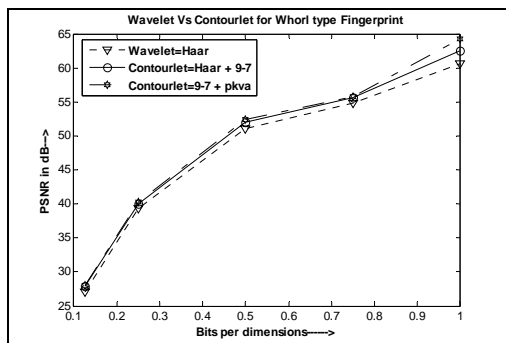

Fig. 11 Plot of PSNR Vs bit rate for Whorl type fingerprint

directional filter combinations. The plot of bit rate against PSNR for different pyramidal and directional filter bank is shown in Fig.10.

Table II gives the result of the proposed scheme against wavelet based MSVQ for 'whorl' type fingerprint and the corresponding plot is shown in Fig.11. The plot of bit rate against PSNR for different pyramidal and directional filters for 'whorl' type fingerprint is shown in Fig.12. From the Table II, we can infer that the proposed scheme outperforms the wavelet based MSVQ. In the case of 'whorl' type fingerprint, the '5-3' and 'pkva' as the pyramidal and directional filter combination gives better PSNR result when compared to other pyramidal and directional filter combinations.

Table III gives the result of the proposed scheme against wavelet based MSVQ for 'tented arch' type fingerprint and the corresponding plot is shown in Fig.13. From the Table III, we can infer that the proposed scheme outperforms the

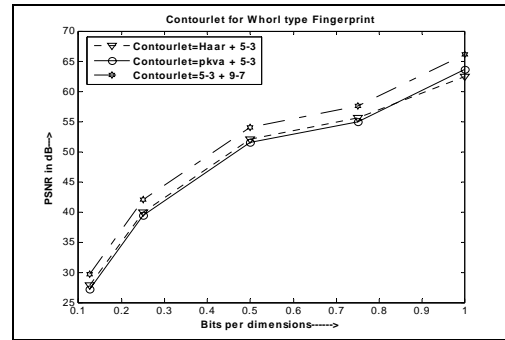

Fig. 12 Comparison of bit rate Vs PSNR between different pyramid and directional filters for Whorl type Fingerprint

TABLE III
PSNR VALUES FOR WAVELET VS CONTOURLET TRANSFORM FOR TENTED ARCH TYPE FINGERPRINT

Bpd Filters	0.125	0.25	0.5	0.75	1.0
Wavelet: 'Haar'	27.8779	40.0652	51.6030	55.5409	61.5637
Contourlet:					
P-filter: 'Haar' D-filter: '9-7'	27.9290	40.1262	51.9707	55.6631	62.3710
P-filter: 'Haar' D-filter: 'pkva'	27.9205	40.1208	51.9595	55.6605	62.3744
P-filter: 'Haar' D-filter: '5-3'	27.8300	40.0427	51.8884	55.5895	62.3155
P-filter: '9-7' D-filter: 'pkva'	27.1465	39.3296	51.4179	54.9379	63.4569
P-filter: 'pkva' D-filter: '9-7'	27.2113	39.5365	51.5463	55.0195	63.5487
P-filter: '5-3' D-filter: '9-7'	28.4193	40.5040	52.5302	56.0321	64.6424
P-filter: '9-7' D-filter: '5-3'	27.9202	40.0989	52.2367	55.7056	64.2819
P-filter: 'pkva' D-filter: '5-3'	27.1401	39.4470	51.4635	54.9351	63.4787
P-filter: '5-3' D-filter: 'pkva'	28.7065	40.7743	52.8632	56.3000	64.9559

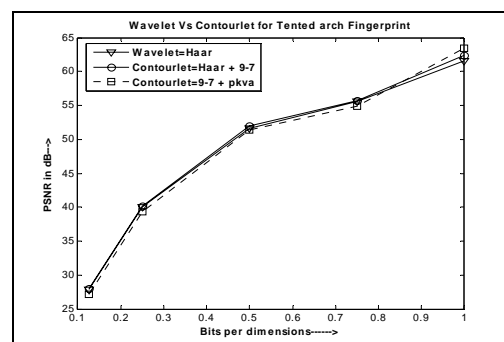

Fig. 13 Plot of PSNR Vs bit rate for Tented Arch type fingerprint

wavelet based MSVQ. In the case of 'tented arch' type fingerprint, the '5-3' and 'pkva' as the pyramidal and directional filter combination gives better PSNR result when

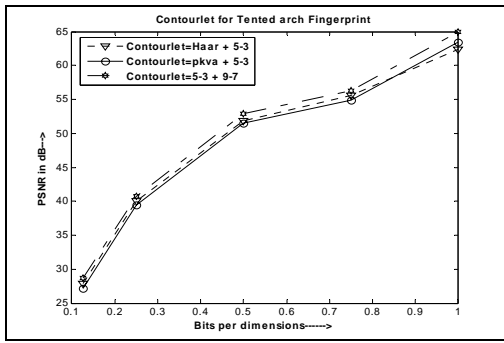

Fig. 14 Comparison of bit rate Vs PSNR between different pyramid and directional filters for Tented arch type Fingerprint

compared to other pyramidal and directional filter combinations which is evident from Fig.14.

Fig 15, 16 and 17 shows the original and reconstructed ‘arch’, ‘whorl’ and ‘tented arch’ type fingerprints at different bit rates. The pyramidal and directional filters chosen are ‘5-3’ and ‘pkva’ respectively. From the figures, it is obvious that as the bit rate increases, the visual quality of the reconstructed image increases which is in accordance with Rate-Distortion theory. The execution time and the PSNR values for different stages in MSVQ is given in Table IV and the corresponding plot is shown in Fig. 18. From the table and figure, it is clear that if we incorporate more stages in MSVQ, the quality of the reconstructed image is improved but the execution time is more.

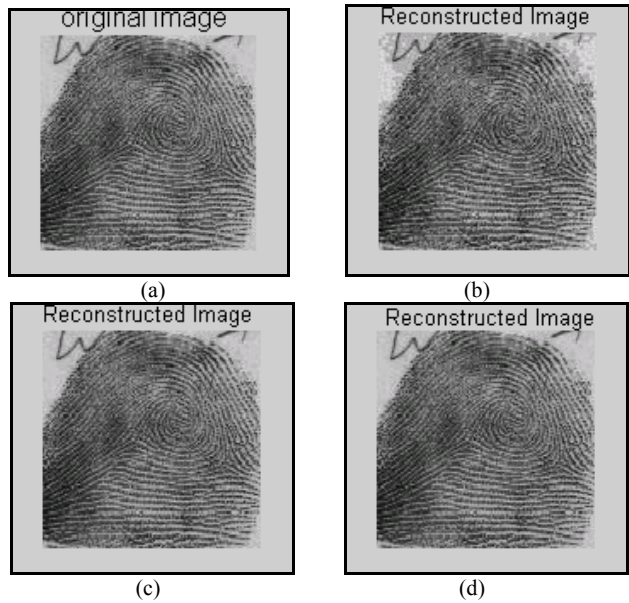

Fig. 16 Original and decoded 128 x 128 Whorl type Fingerprint (a) Original image (b) bpd=0.125, (c) bpd=0.25, (d) bpd=1.0 using P-filter= ‘5-3’ and D-filter= ‘pkva’

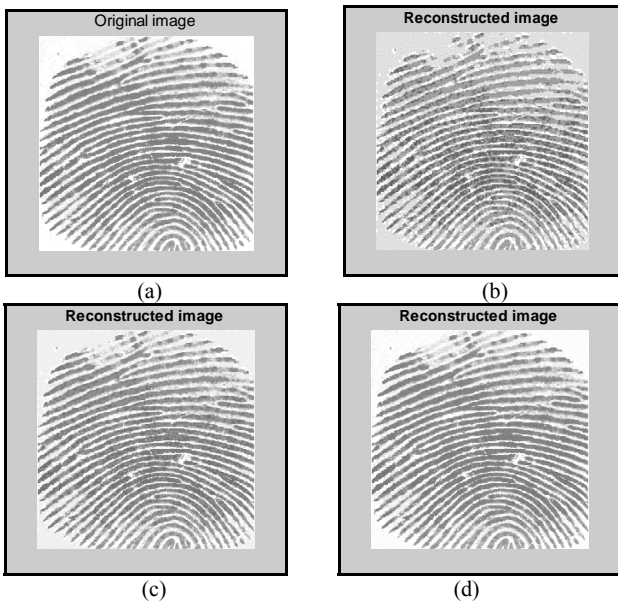

Fig. 15 Original and decoded 256 x 256 Arch type Fingerprint (a) Original image (b) bpd=0.125, (c) bpd=0.25, (d) bpd=1.0 using P-filter= ‘5-3’ and D-filter= ‘pkva’

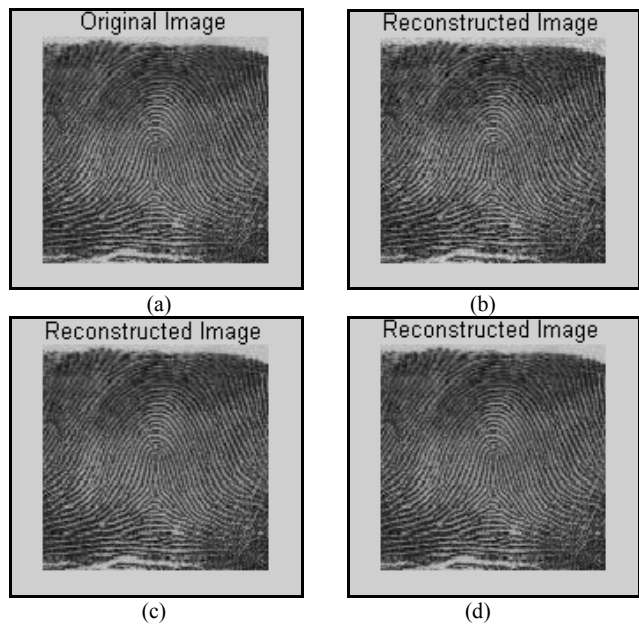

Fig. 17 Original and decoded 128 x 128 Tented arch type Fingerprint (a) Original image (b) bpd=0.125, (c) bpd=0.25, (d) bpd=1.0 using P-filter= ‘5-3’ and D-filter= ‘pkva’

TABLE IV
CONTOURLET TRANSFORM WITH DIFFERENT STAGES IN MSVQ FOR
WHORL TYPE FINGERPRINT

Bits per dimensions (bpd)	Single Stage MSVQ		Two Stage MSVQ		Three Stage MSVQ	
	PSNR in dB	Execution time in seconds	PSNR in dB	Execution time in seconds	PSNR in dB	Execution time in seconds
0.125	17.4918	0.9070	29.7444	1.2350	42.0052	1.4530
0.25	23.6555	0.9220	42.0062	1.2500	60.1104	1.4690
0.5	29.7444	0.9370	54.0574	1.3440	78.0889	1.6100
0.75	33.5023	1.0470	57.5604	1.3750	81.7458	1.7030
1.0	36.0350	1.0620	66.1263	1.4060	90.7871	1.8440

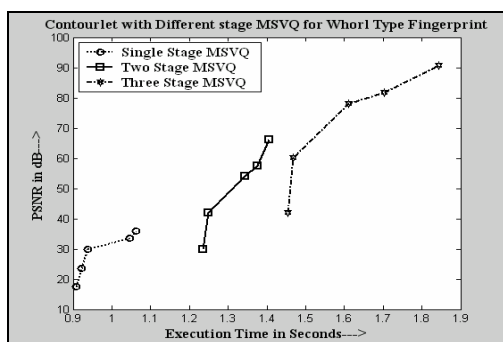

Fig. 18 Plot of PSNR Vs Execution time for Whorl type Fingerprint

VI. CONCLUSION

In this paper, compression of fingerprints using contourlet transform and multistage vector quantization has been presented. An extensive result has been taken on different types of fingerprints. It can be seen that the PSNR obtained by contourlet transform is higher than that of wavelet transform. Hence, a better image reconstruction is possible with less number of bits, by using contourlet transform. Here, only four filter combinations are considered. We are currently pursuing with other filter combinations. The experimental results reveal the fact that MSVQ is suitable for low bit rate image coding. The proposed scheme yields encoding outputs of good quality around 0.5 bits per dimension (bpd) and very good results at around 1 bpd. This scheme can easily be extended to include more stages in MSVQ to improve the output image quality.

ACKNOWLEDGMENT

The authors wish to thank their teachers Dr. S. Jayaraman, Dr. N. Malmurugan for the continued support and encouragement. They also thank their present institution where they are working.

REFERENCES

[1] Pennebaker W.B. and Mitchell J.L., JPEG-Still Image Data Compression Standards. Van Nostrand Reinhold, 1993.

- [2] C.M. Brislawn, J.N. Bradley and R.J. Onyschczak and T. Hopper, "The FBI Compression Standard for Digitized Fingerprint Images," in 1996 Proc. SPIE, vol.2847, pp. 344-355.
- [3] M.Antonini, M.Barlaud, P. Mathieu, and I.Daubechies, "Image coding using wavelet transform," IEEE Trans. Image Proc, pp.205-220, Apr.1992.
- [4] M. N. Do and M. Vetterli, "The contourlet transform: an efficient directional multiresolution image representation," IEEE Trans. Of Image Processing, vol.14, no.12, pp. 2091-2106, Dec. 2004.
- [5] B.H.Juang and A.H.Gray, "Multiple stage vector quantization for speech coding," in 1982 Proc. IEEE Int.Conf.Acoust, Speech, Signal Processing (Paris, France), pp.597-600.
- [6] K.P. Soman and K.I. Ramachandran, Insight into Wavelets from Theory to Practice, Prentice Hall India, New Delhi, 2002, ch.9.
- [7] A.Gersho and R.M. Gray, Vector Quantization and Signal Compression. Boston, MA: Kluwer, 1992.
- [8] M. N. Do and M.Vetterli, "Pyramidal directional filter banks and curvelets," in 2001 Proc. Of IEEE Int. Conf. on Image Proc, vol.3, pp.158-161, Thessaloniki, Greece.
- [9] D.D. Y. Po and M. N. Do, "Directional multiscale modeling of images using the contourlet transform," IEEE Trans. on Image Processing, to appear, Jun. 2006.
- [10] P. J. Burt and E. H. Adelson, "The Laplacian pyramid as a compact image code," IEEE Trans. on Commun. vol. 31, no. 4, pp. 532-540, 1983.
- [11] M. N. Do, "Directional Multiresolution Image Representations," Ph.D.Thesis, EPFL, Lausanne, Switzerland, Dec. 2001.
- [12] R. H. Bamberger and M. J. T. Smith, "A filter bank for the Directional decomposition of images: theory and design," IEEE Trans. on Signal Processing, vol. 40, no. 4, pp. 882-893, Apr. 1992.
- [13] Jayshree Karlekar, P.G. Poonacha and U.B. Desai, "Image Compression using Zerotree and Multistage Vector Quantization", ICIP, Vol.2, pp.610, 1997.
- [14] Hosam Khalil, Kenneth Rose, "Multistage vector quantizer optimization for packet networks," IEEE Trans. Signal Proc. Vol. 51, No.7, pp.1870-1879, July 2003.
- [15] Y. Linde, A. Buzo and R.M.Gray, "An algorithm for vector quantizer design," IEEE Trans. Commun. Vol.28, pp.84-95, Jan.1980.
- [16] R. Sudhakar, R. Karthiga and S. Jayaraman, "Fingerprint compression using Contourlet Transform with Modified SPIHT algorithm", IJCE, vol.5, No.1, pp.3-10, Winter-Spring 2006.
- [17] www.biometrics.cse.msu.edu/fingerprint.html.