

Fault Classification of a Doubly FED Induction Machine Using Neural Network

A. Ourici

Abstract—Rapid progress in process automation and tightening quality standards result in a growing demand being placed on fault detection and diagnostics methods to provide both speed and reliability of motor quality testing. Doubly fed induction generators are used mainly for wind energy conversion in MW power plants. This paper presents a detection of an inter turn stator and an open phase faults, in a doubly fed induction machine whose stator and rotor are supplied by two pulse width modulation (PWM) inverters. The method used in this article to detect these faults, is based on Park's Vector Approach, using a neural network.

Keywords—Doubly fed induction machine, inter turn stator fault, neural network, open phase fault, Park's vector approach, PWM inverter.

I. INTRODUCTION

THE rational use of electrical energy implies having transportation networks capable of transmitting large quantities of electrical energy over long distances as well as adequate storage plants. Nearly all the pump turbine groups operating today consist of synchronous motor-generators working at the network frequency and therefore at constant speed. The performance and efficiency of such groups can be significantly improved by using variable speed motor – generators and more specifically doubly fed asynchronous motor – generators (DFIM); nowadays there is a strong demand for their reliable and safe operation. The manufacturers and users of such machines initially relied on simple protections such as over-current, over-voltage, earth fault, etc., to ensure safe operation. However, as the tasks performed by these machines grew increasingly complex, improvements were also sought in the field of fault diagnosis. In the industry, methods based on analytical models of the motor systems are still the most common choices for condition monitoring of electrical machinery. However, during the last decade also applications of different kinds of data- based modes such as Neural Network (NN) have established a firm position.

We propose in this article to classify two kinds of faults: an interturn stator fault and an open phase fault in a doubly fed induction machine, based on Park's Vector Approach, using a Neural Network.

Neural networks are the object of many researches nowadays thanks to their capacity of training, approximation and generalization.

The proposed method shows good results to classify safe and damaged machine using this method.

II. DESCRIPTION AND MODELING OF DFIM

The proposed system is shown on Fig. 1, it is constituted by two pulse width modulation inverters supplying separately the stator and the rotor of the machine [1] [2].

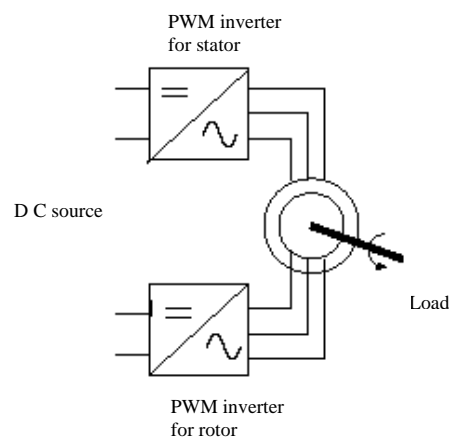

Fig. 1 DFIM supplied by two PWM inverters

We choose three levels PWM for both stator and rotor inverters, it is constitute of three arms, every one has four switches formed by a transistor and a diode as shown in Fig. 2.

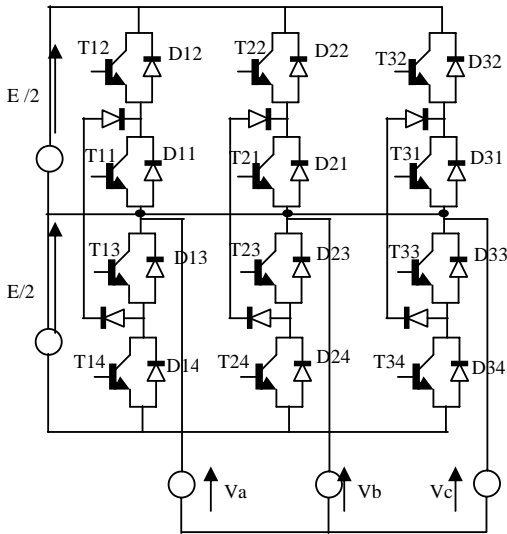

Fig. 2 General diagram of a three level PWM inverter

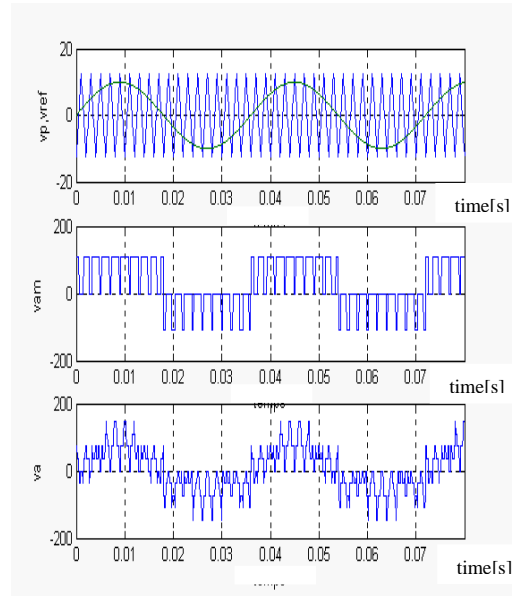

Fig. 3 Carrying voltage, simple voltage and phase voltage

The simple voltages are obtained starting from the following conditions:

If $(V_{ref} = V_p)$ and $(V_{ref} > 0)$

$$\Rightarrow V_K = +E/2$$

If $(V_{ref} = V_p)$ and $(V_{ref} < 0)$

$$\Rightarrow V_K = -E/2$$

If $V_{ref} = V_p \Rightarrow V_K = 0$

With

V_{ref} : reference voltage standard;

V_p : carrying;

V_K : potential of the node K.

Stator and rotor voltages of the machine after Park transformation are given by [3]:

$$\begin{cases} V_{ds} = R_s I_{ds} + \frac{d}{dt} \psi_{ds} - \frac{d\theta_s}{dt} \psi_{qs} \\ V_{qs} = R_s I_{qs} + \frac{d}{dt} \psi_{qs} + \frac{d\theta_s}{dt} \psi_{ds} \end{cases} \quad (1)$$

$$\begin{cases} V_{dr} = R_r I_{dr} + \frac{d}{dt} \psi_{dr} - \frac{d\theta_r}{dt} \psi_{qr} \\ V_{qr} = R_r I_{qr} + \frac{d}{dt} \psi_{qr} + \frac{d\theta_r}{dt} \psi_{dr} \end{cases} \quad (2)$$

Stator and rotor fluxes are given by:

$$\begin{cases} \psi_{ds} = L_s I_{ds} = M I_{dr} \\ \psi_{qs} = L_s I_{qs} + M I_{qr} \\ \psi_{dr} = L_r I_{dr} + M I_{ds} \\ \psi_{qr} = L_r I_{qr} + M I_{qs} \end{cases} \quad (3)$$

Mechanic equation is given by:

$$C_{em} = C_r + J \frac{d\Omega}{dt} + f\Omega \quad (4)$$

The Vector's Park Approach is a relatively new diagnostic technique, which has been successfully applied in the diagnosis of rotor faults, inter turn stator faults and unbalanced supply voltage [4] [5].

The instantaneous line currents of the stator are transformed into Park's vector using (5). An undamaged machine theoretically shows a perfect circle as shown in Fig. 4. An unbalance due to turn faults results in an elliptic representation of the Park's vector as shown in Fig. 5.

$$\begin{bmatrix} ids \\ iqs \end{bmatrix} = \begin{bmatrix} \sqrt{\frac{2}{3}}ia & \frac{-1}{\sqrt{6}}ib & \frac{-1}{\sqrt{6}}ic \\ 0 & \frac{1}{\sqrt{2}}ib & \frac{-1}{\sqrt{2}}ic \end{bmatrix} \quad (5)$$

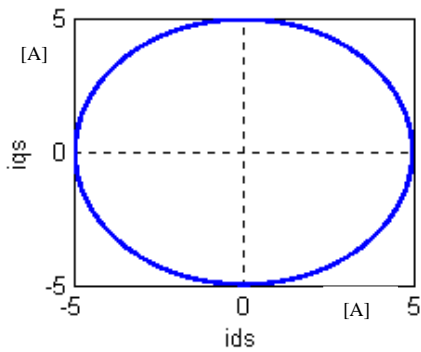

Fig. 4 Park's vector of healthy machine

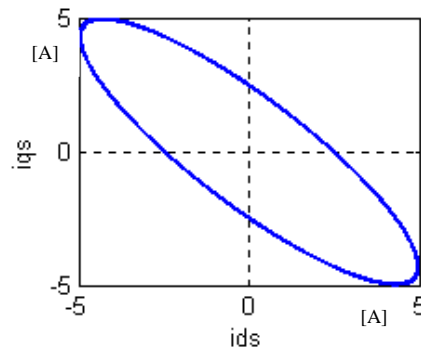

Fig. 5 Park's vector of faulty machine (Inter turn stator fault)

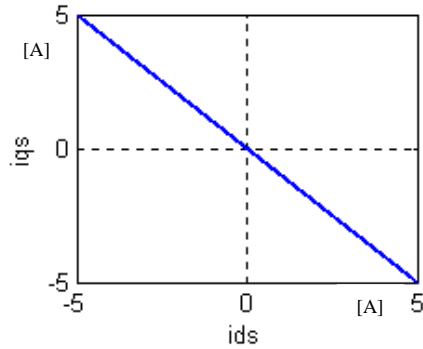

Fig. 6 Park's vector of faulty machine (Open phase)

We choose to use a neural network to classify the state of the machine (safe or faulty).

We attribute for every shape of the Park's vector a label describing the operating state of the machine:

- The state "Safe machine" is classified by a label "0" at the neural network output.
- The state "machine with an open phase fault" is classified by a label "1" at the neural network output.
- The state "machine with an inter turn stator fault" is classified by a label "2" at the neural network output.

For the construction of the multiple coatings network [6] we adopt the error retro propagation method which is based on the gradient descent algorithm.

The calculation stages of the neural network can be resumed like this:

a- The output of the latent layer

$$y_i = f_j^c \left(\sum_{i=1}^n w_{ji}^c x_i + b_j^c \right) \quad (6)$$

b- The outputs of the output layer

$$o_k = f_k^s \left(\sum_{j=1}^m w_{kj}^s y_j + b_k^s \right) \quad (7)$$

c- The error terms of the output units

$$\delta_k^s = (t_k - o_k) f_k^{s'} \left(\sum_{j=1}^m w_{kj}^s y_j + b_k^s \right) \quad (8)$$

d- The error terms of the latent layer

$$\delta_j^c = f_j^{c'} \left(\sum_{i=1}^n w_{ji}^c x_i + b_j^c \right) \cdot \sum_{k=1}^l \delta_k^s w_{kj}^s \quad (9)$$

e- Weight and bias adjustment of the output layer

$$w_{kj}^s(t+1) = w_{kj}^s(t) + \eta \delta_k^s y_j \quad (10)$$

$$b_k^s(t+1) = b_k^s(t) + \eta \delta_k^s \quad (11)$$

f- Weight and bias adjustment of the latent layer

$$w_{ji}^c(t+1) = w_{ji}^c(t) + \eta \delta_j^c x_i \quad (12)$$

$$b_j^c(t+1) = b_j^c(t) + \eta \delta_j^c \quad (13)$$

The procedure is repeated until the performance criterion is satisfied.

When the learning procedure is finished, the synaptic coefficients take an optimal values and the network can be operational.

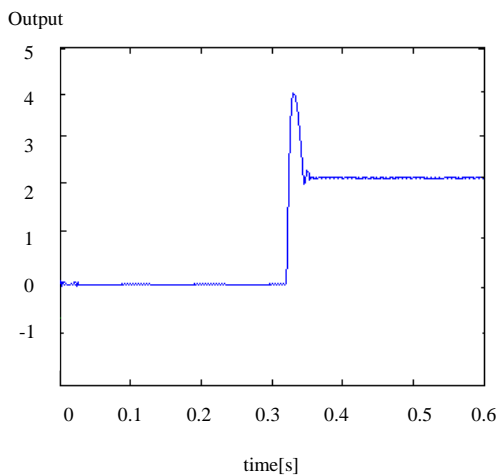

Fig. 7 The neural network test for an inter turn stator fault

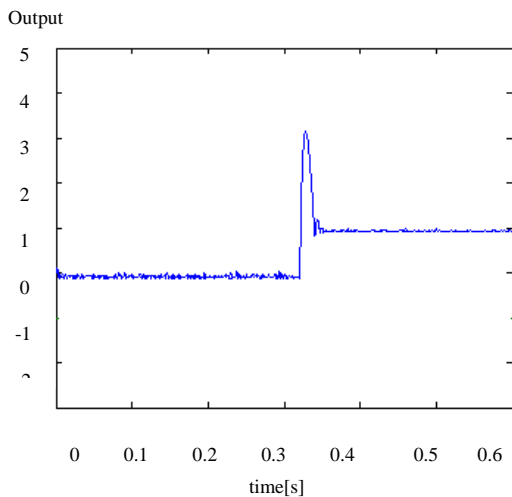

Fig. 8 The neural network test for an open phase fault

III. RESULTS ANALYSIS

Fig. 3 shows the carrying voltage, simple voltage and phase voltage of the three levels inverters used. Fig. 4 presents the diagram of Park's vector in the case of a healthy machine, and Fig. 5 shows the elliptic shape of Park's vector in the case of an inter turn stator fault. Fig. 6 presents the shape of Park's vector with an open phase fault. Fig. 7 presents the response of the neural network constituted, at time equals to 0.32s we induce an inter turn stator fault and the test grows automatically to label "2", before this time the test was stabilized on label "0" which constitute a healthy machine. Fig. 8 shows the response of the neural network with an open phase stator fault at 0.32s, the test grows at this time to label "1".

IV. CONCLUSION

Neural network based on Park's Vector Approach has been successfully applied to the detection of stator turn faults in a doubly fed induction generator. This method of detection, works well if the machine being diagnosed operates only in steady state. It can be said that this method in addition of its simplicity, shows good results.

REFERENCES

- [1] A. Masmoudi, A. Toumi & M. Kamoun, "Power analysis and efficiency optimization of a doubly fed synchronous machine", Proc. Electric Machines and Power Systems 21, pp 473-491, 1993.
- [2] Y. Kawabata, E. Ejiogu & T. Kawabata, "Vector controlled double inverter fed wound rotor induction motor suitable for high power drives .IEEE Trans. Industry Applications 35 no. 5, pp 1058-1066, sept./oct 1999.
- [3] Paul Etienne VIDAL, "Commande non linéaire d'une machine asynchrone à double alimentation", Thesis of doctorate, Toulouse France, december 2004.
- [4] S.M.A. Cruz and A.J. Marque Cardoso, " Stator winding fault diagnosis in three phase synchronous and asynchronous motors, by the Extended Park's Vector Approach", IEEE Trans on Industry applications, vol. 37, No5, sept/oct 2001.
- [5] Mohamed El Hachemi Benbouzid, "A review of induction motors signature analysis as a medium for faults detection", IEEE Trans on Industrial Electronics, vol 47 No 5, October 2000.
- [6] S. Chen and S.A. Billings, "Neural network for nonlinear system modeling and identification", Int. J. Control, vol. 56, No 2, pp 319-346, Aug 1992.

A. Ourici was born in Annaba, Algeria, in 1973. She obtained a mathematic Baccalaureate in 1990, the engineer degree in 1995, the M.S degree in 1998, and PhD in electrical engineering in 2007. Her major field of research is the faults detection in AC machines.