

# FACTS Based Stabilization for Smart Grid Applications

Adel M. Sharaf, Foad H. Gandoman

**Abstract**—Nowadays, Photovoltaic-PV Farms/ Parks and large PV-Smart Grid Interface Schemes are emerging and commonly utilized in Renewable Energy distributed generation. However, PV-hybrid-Dc-Ac Schemes using interface power electronic converters usually has negative impact on power quality and stabilization of modern electrical network under load excursions and network fault conditions in smart grid. Consequently, robust FACTS based interface schemes are required to ensure efficient energy utilization and stabilization of bus voltages as well as limiting switching/fault onrush current condition. FACTS devices are also used in smart grid-Battery Interface and Storage Schemes with PV-Battery Storage hybrid systems as an elegant alternative to renewable energy utilization with backup battery storage for electric utility energy and demand side management to provide needed energy and power capacity under heavy load conditions. The paper presents a robust interface PV-Li-Ion Battery Storage Interface Scheme for Distribution/Utilization Low Voltage Interface using FACTS stabilization enhancement and dynamic maximum PV power tracking controllers.

Digital simulation and validation of the proposed scheme is done using MATLAB/Simulink software environment for Low Voltage-Distribution/Utilization system feeding a hybrid Linear-Motorized inrush and nonlinear type loads from a DC-AC Interface VSC-6-pulse Inverter Fed from the PV Park/Farm with a back-up Li-Ion Storage Battery.

**Keywords**—AC FACTS, Smart grid, Stabilization, PV-Battery Storage, Switched Filter-Compensation (SFC).

## I. INTRODUCTION

**D**URING the last two decades, renewable energy generation and utilization gained momentum and acceptance for sustainable and environmentally friendly green energy drive and interface to smart grid electrical networks. Hybrid AC-DC interface schemes of distributed generation and integration within the smart power grid can enhance AC system security, reliability and provide effective energy management and stabilization of the AC system with improved stability and stabilization under different fault conditions.

Modern smart grid dynamic will comprises green renewable energy and distributed generation as well as FACTS stabilization and filtering devices to alleviate severe voltage instability, boost voltage regulation, and improve power factor and energy efficient utilization using switched/modulated FACTS based devices and flexible dynamic control systems are fully utilized [1], [2]. Therefore, the switched/modulated

Foad H. Gandoman is with the Electrical Machine Lab, Department of Computer and Electrical Engineering, University of Kurdistan, Iran (corresponding author to provide phone: (+98)871 33713186 fax: (+98)871 33668513; e-mail: f.haidari.elect@gmail.com).

Adel M. Sharaf is with the Sharaf Energy Systems, Incorporated, 147 Berkley Drive, Fredericton, NB, E3C2P2, Canada (e-mail: profdramsaraf@gmail.com).

filter compensation FACTS schemes simplify the concept of FACTS fast stabilization using low cost devices and dynamic/flexible control strategies to improve security and system stabilization of smart grid networks supplied by renewable wind and small hydro energy sources [3]-[6].

In this paper a new switched filter compensator (SFC) scheme is validated using dynamic controller for stabilization and enhancement of AC networks under fault and load variations as well as changes in PV Insolation and Junction temperatures. The low cost filter scheme utilized a dual IGBT/GTO switch that controlled by dynamic error driven control strategies using a multi-loop dynamic error driven coordinated dual regulation control scheme and a weighted-modified fast acting PID controller with additional error squared and rate adjusting supplementary loops to improve fast response.

This paper is organized as follows. Following this introduction, The FACTS scheme is described in Section II. Case study is explained in Section III. The controllers are presented in Part IV. Finally, Sections V and VI present the Matlab/Simulink digital simulation results under open and short circuit conditions and conclusions, respectively

## II. THE FACTS SCHEME

The proposed FACTS filter and compensation device is a member of a family of modulated switched/modulated power filters and switched capacitor compensators [7]-[13].

It is a low cost hybrid switched/modulated power filter which comprises a shunt and series filters to mitigate harmonic and reduce total harmonic distortion as well as improve power quality and power factor using a switched shunt capacitor bank and two series connected fixed-capacitor banks connected to the AC side of a one-arm uncontrolled rectifier. In addition, a tuned arm filter is connected to the ground of system.

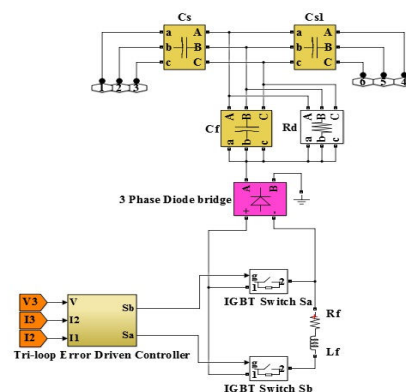

Fig. 1 New Switched filter SFC scheme

Two modes of operation can be defined for the SFC using the complementary controlled solid state switches, S1 and S2. These two switches follow NOT LOGIC command. That is, while S1 is on, S2 is off and vice versa. Configuration of the proposed SFC is shown in Fig.1.

III. CONTROL STRUCTURE

There are two type controllers in the proposed system. Fig. 2 shows SFC-power filter controller using a dynamic tracking regulator with three loops. The first loop is a voltage regulator that tracks reference voltage ( $V_m\text{-ref}$ ). The second and third loops are dynamic type error tracking loops to stabilize current variations and limit any sudden power excursions, respectively.

The second controller loop is used to controller the energy flow from the PV-Solar array via the VSI-6 pulse inverter and Dc-Ac interface as shown in Fig. 3 using the photovoltaic current, photovoltaic voltage and photovoltaic power inputs. Every input error is obtained by taking the difference between the real and delayed real input values. The photovoltaic voltage  $r$ , the photovoltaic error and the photovoltaic power errors are multiplied by the selected weighting factors ( $I_\gamma$ ,  $v_\gamma$  and  $p_\gamma$ ) and the output summations is a total Tri-loop error. The tri-loop error is multiplied by a weight factor  $K_h$ .

This will ensure time-descaling and weighting of the auxiliary loops.

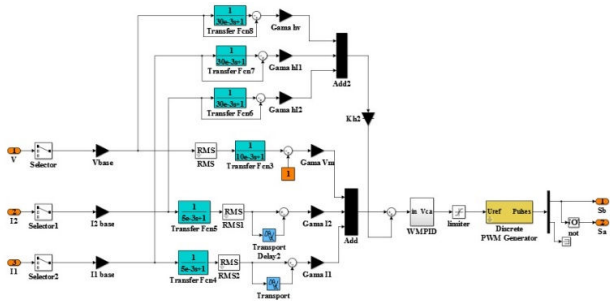

Fig. 2 Switched Power filter SFC-Dynamic Controller

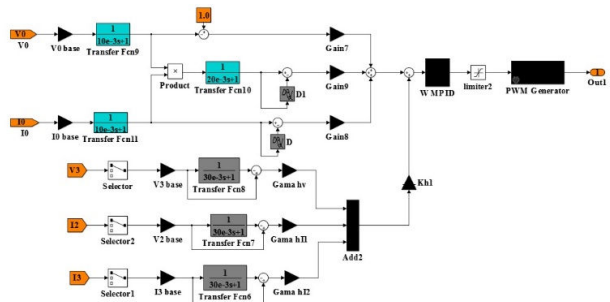

Fig. 3 PV-Inverter VSI-6 Pulse Dynamic Controller

The global output signal of the dynamic error driven controller is followed by a modified Weighted-Modified PID (WMPID) controller displayed in Fig. 4. WMPID includes an error sequential activation supplementary loop, ensuring fast dynamic response and effective damping of large excursions,

in addition to conventional PID structure. Moreover, the output signal of the Weighted Modified PID controller enters a PWM signal generator. On-off switching sequences produced by PWM define two operating modes of the FACTS device of SFC and PV-hybrid system.

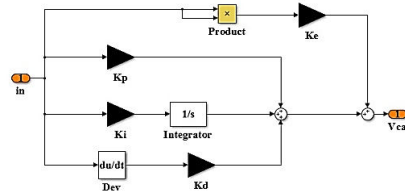

Fig. 4 Modified weighted PID controller with additional error squared compensating/dynamic accelerating loop

IV. STUDY SYSTEM

The sample study AC grid network with the PV array interface is shown in Fig. 5. It comprises a local hybrid load (linear, nonlinear and induction motor type loads) and is connected to an infinite bus through 6 km transmission line. The unified AC system, SFC-filter/compensator and the controller parameters are given in Tables I and II, respectively.

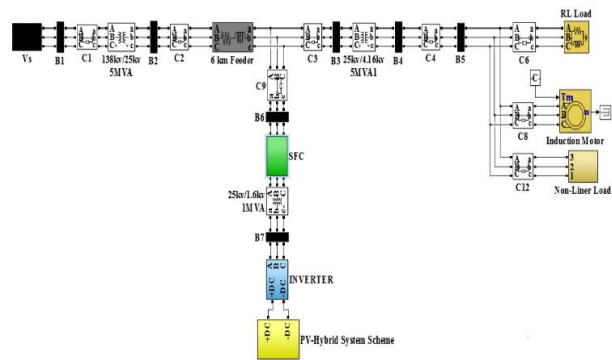

Fig. 5 Study System

V. RESULTS

To validate the FACTS SFC Scheme dynamic stabilization and efficient energy utilization with proposed control schemes for stabilization of the host smart grid under short and open circuit condition, the MATLAB/Simulink Software Environment was utilized in all digital simulation, a 3-phase short circuit in middle bus is applied at time 0.02 sec of the AC grid, and it is cleared after 0.02 sec. The results of the simulation under short circuit condition in PV bus and load bus has been shown in Figs. 6-11 and Figs 12-17, respectively. Moreover, open circuitdynamic simulation results for load bus are shown in Figs.18-23. Additionally, all parameters of the elements which are used in simulation are mentioned in Appendix A and B. The FACTS SFC scheme was validated to be effective in stabilizing bus voltages, improving power factor and reducing inrush currents under short and open circuit faults in the case study.

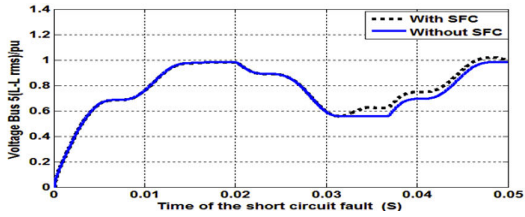

Fig. 6 RMS voltage waveform in PV bus under short circuit operation

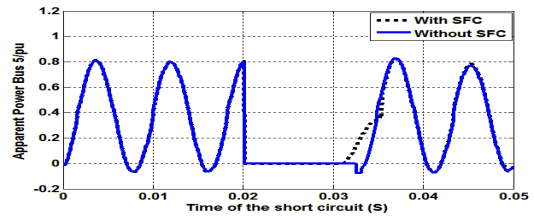

Fig. 11 Apparent power waveform in PV bus under short circuit operation

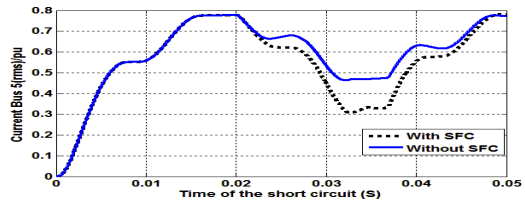

Fig. 7 RMS Current waveform in PV bus under short circuit operation

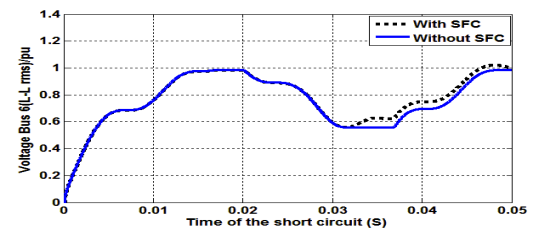

Fig. 12 RMS voltage waveform in load bus under short circuit operation

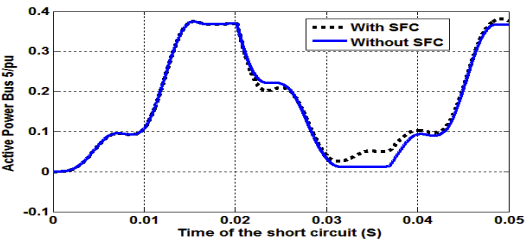

Fig. 8 Active power waveform in PV bus under short circuit operation

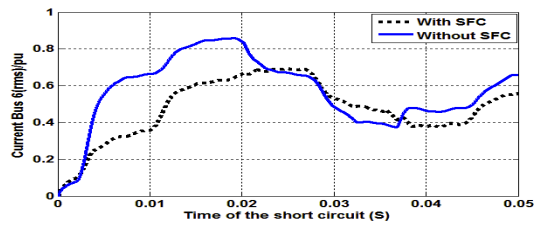

Fig. 13 RMS current waveform in load bus under short circuit operation

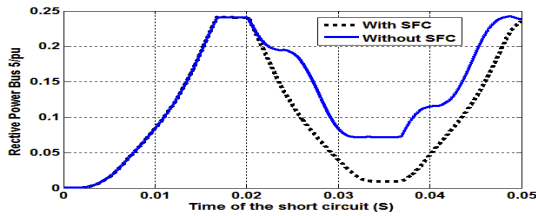

Fig. 9 Reactive power waveform in PV bus under short circuit operation

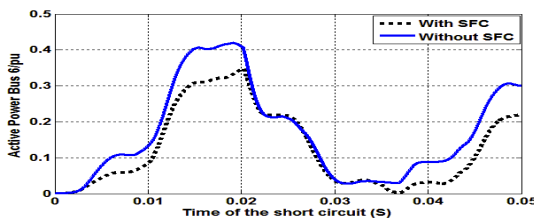

Fig. 14 Active power waveform in load bus under short circuit operation

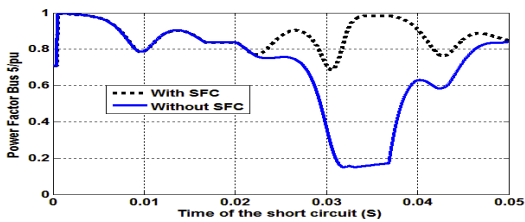

Fig. 10 Power Factor waveform in PV bus under short circuit operation

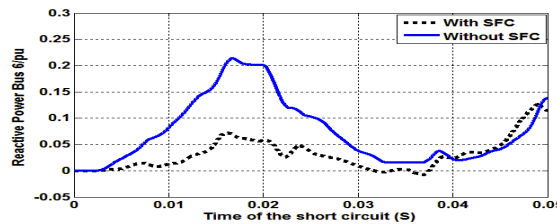

Fig. 15 Reactive power waveform in load bus under short circuit operation

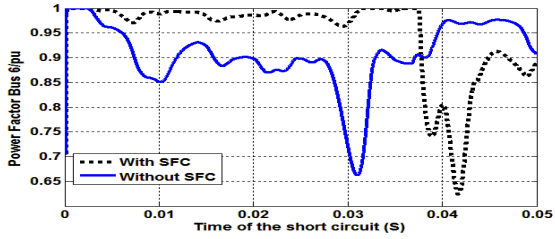

Fig. 16 Power factor waveform in load bus under short circuit operation

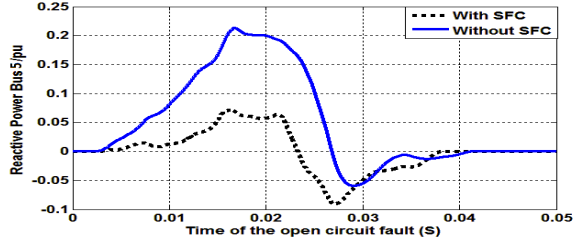

Fig. 21 Reactive power waveform in load bus under open circuit operation

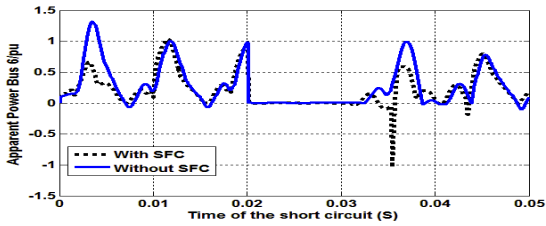

Fig. 17 Apparent waveform in load bus under short circuit operation

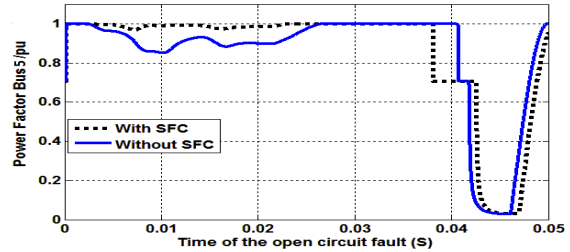

Fig. 22 Power factor waveform in load bus under open circuit operation

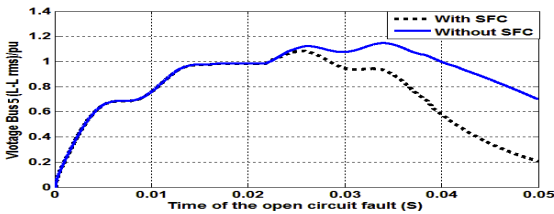

Fig. 18 RMS voltage waveform in load bus under open circuit operation

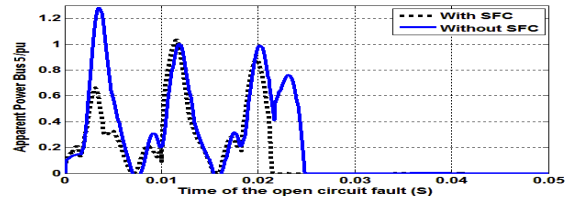

Fig. 23 Apparent power waveform in load bus under open circuit operation

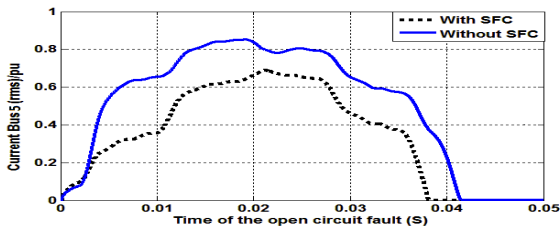

Fig. 19 RMS current waveform in load bus under open circuit operation

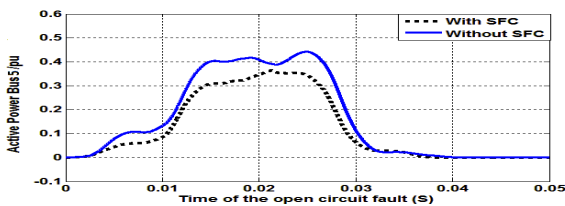

Fig. 20 Active power waveform in load bus under open circuit operation

## VI. CONCLUSION

This paper presents a novel switched/modulated power filter compensator (SFC) scheme. The FACTS based switched/Modulated Filter-capacitor compensator with the proposed dynamic controllers using time-descaled tri-loop error driven regulation and a modified-weighted PID Controller. The digital simulation results validated the SFC FACTS Scheme for effective AC system stabilization, power factor improvement, voltage stabilization, power factor correction and power quality enhancement. The proposed FACTS based SFC-Filter/compensator scheme can be extended to other applications using distributed/dispersed renewable energy interface and green energy utilization systems and easily modified for other control objectives such as feeder loss reduction and DSM-demand side Management in addition to voltage stabilization and efficient utilization. Other applications include V2H/V2G Battery charging schemes using hybrid PV-NG Powered Fuel Cell and smart grid AC-DC Interface.

TABLE I  
THE AC SYSTEM AND SFC-FILTER PARAMETERS

Transmission Line	25 Kv (L-L), 6km R/Km=0.35 $\Omega$ , L/Km=0.4 Mh
Infinite Bus	138 Kv, X/R=10
SFC	$C_s=14\mu\text{f}$ , $C_{s1}=14\mu\text{f}$ , $C_{sh1}=225\mu\text{f}$ $R_f=0.15\Omega$ , $L_f=3\text{mh}$
Local Hybrid Ac Load	Induction Motor
	0.2 Mva, 4 Poles $R_s=0.01965\text{pu}$ , $L_s=0.0397\text{ Pu}$ $R_r=0.01909\text{pu}$ , $L_r=0.0397\text{ Pu}$ $L_m=1.354\text{ Pu}$
	Linear Load $P=0.1\text{ Mw}$ , $Q=0.043\text{ Mvar}$
PV-Hybrid System	Nonlinear Load 0.1 Mva, $\text{Pf}=0.9$
	Photovoltaic Cell $V_{\text{out}}=1600\text{v}$ , $P_{\text{out}}=1\text{mw}$
Power Transformer	Battery Lithium-Ion, 1600v, 1750ah, S.O.C 10%
	$T_1$ 138/25kv, 5 Kva
	$T_2$ 25/4.16kv, 5 Kva
	$T_3$ 25/1.6kv, 1 Kva

TABLE II  
THE CONTROLLER PARAMETERS

Device	Value
PV-Hybrid Scheme	$R_0=R_b=0.5$ , $L_0=R_b=0.05\text{mh}$ , $C_0=1275\text{mf}$
PV Controller Gains	$K_e=1$ , $K_p=25$ , $K_i=2$ , $K_d=1$ , PWM Frequency $F_s=1750\text{ Hz}$
SFC Controller Gains	$K_e=1$ , $K_p=25$ , $K_i=2$ , $K_d=1$ , PWM Frequency $F_s=2500\text{ Hz}$
LC Filter	$L=0.1\text{mh}$ , $R=0.5\Omega$ , $C=200\text{mf}$

## REFERENCES

- [1] A. M. Sharaf, A. A. Abdelsalam, A. A. Eldesouky, A.A. Sallam, "a novel FACTS based modulated power filter compensation scheme for smart electric grid stabilization and efficient utilization", International Journal of Distributed Energy Resources, vol. 7, no. 4, pp. 311-327, 2011.
- [2] Abdelazeem A. Abdelsalam, Mohammed E. Desouki, Adel M. Sharaf, "Power quality improvement using FACTS power filter compensation scheme" J. Electrical Systems, vol. 9, no. 1, pp. 86-96, 2013.
- [3] A. M. Sharaf, A. A. Abdelsalam, "A novel switched filter compensation scheme for power quality enhancement and loss reduction" International Symposium on Innovations in Intelligent Systems and Applications ,INISTA 2011, Turkey, pp. 398- 403.
- [4] A. M. Sharaf, Hong Huang, and Liuchen Chang, "Power Quality and Nonlinear Load Voltage Stabilization Using Error Driven Switched Passive Power Filter," IEEE Proc. on International Symposium on Industrial Electronics, pp. 616-621, 1995.
- [5] M. Rastogi, N. Mohan, and A. Edris, "Hybrid Active Filtering of Harmonic Currents in Power Systems," IEEE Trans. On Power Delivery, vol.10, no.4, pp.1994-2000, Oct.2005.
- [6] H. Fujita and H. Akagi, "A Practical Approach to Harmonic Compensation in Power System-series Connection of Passive, Active Filters," IEEE Trans. on Ind. App., vol.27, no.6, pp. 1020-1025, Nov/Dec. 1991.
- [7] A. M. Sharaf and G. Wang, "Wind Energy System Voltage and Energy Enhancement Using Low Cost Dynamic Capacitor Compensation Scheme," IEEE Proc. Electrical, Electronic, and Computer Engineering, pp. 804-807, 2004.
- [8] A. M. Sharaf and B. Khaki, "Navel switched capacitor-filter compensator for smart grid-electric vehicle charging scheme" IEEE International conference on Smart grid engineering, 2012.
- [9] A. M. Sharaf and R. Chhetri, "A Novel Dynamic Capacitor Compensator/Green Plug Scheme for 3-phase 4-wire Utilization Loads," IEEE Proc. CCECE, Ottawa, Ontario, 2006.
- [10] A. M. Sharaf, Yevgen Biletskiy, Hassan A. Mahasneh, "A Low-Cost Modulated Filter Compensator for Energy Efficient Enhancement in AC Utilization Systems," IEEE Proc. CCECE, Vancouver, pp. 140-144, 2007.
- [11] A. M. Sharaf, W. Wang, and H. Altas, "A Novel Modulated Power Filter Compensator for Distribution Networks with Distributed Wind Energy," International Journal of Emerging Electric Power Systems, vol.8, issue.3, Aug. 2007.
- [12] A. M. Sharaf, A. S. Aljankawey, and I. H. Altas, "Dynamic Voltage Stabilization of Stand-Alone Wind Energy Schemes," IEEE Canada Electric Power Conference EPC, pp. 14-19, 2007.
- [13] A. M. Sharaf and Khaled Abo-Al-Ez, "A FACTS Based Dynamic Capacitor Scheme for Voltage Compensation and Power Quality Enhancement," IEEE Proc. ISIE, Montreal, Quebec, Canada, 2006.