

Experimental Study and Analysis of Parabolic trough Collector with Various Reflectors

Avadhesh Yadav, Manoj Kumar, Balram

Abstract—A solar powered air heating system using parabolic trough collector was experimentally investigated. In this experimental setup, the reflected solar radiations were focused on absorber tube which was placed at focal length of the parabolic trough. In this setup, air was used as working fluid which collects the heat from absorber tube. To enhance the performance of parabolic trough, collector with different type of reflectors were used. It was observed For Aluminum sheet maximum temperature is 52.3°C, which 24.22% more than steel sheet as reflector and 8.5% more than Aluminum foil as reflector, also efficiency by using Aluminum sheet as reflector compared to steel sheet as reflector is 61.18% more. Efficiency by using Aluminum sheet as reflector compared to Aluminum foil as reflector is 18.98% more.

Keywords—Parabolic trough collector, Reflectors, Air flow rates.

I. INTRODUCTION

SOLAR energy is a permanent and free of cost source of energy. Non concentrating collectors were used for applications which need low temperature, but many industrial applications require high temperature, which can be obtained by using concentrators. A concentrator is used instead of non concentrating collectors at high temperatures.

Flores and almanza [1] generated steam in parabolic trough concentrators with bimetallic Cu-Fe receivers. The purpose of bimetallic receiver was that the thermal conductivity of the copper causes the homogenization of the wall temperature of the receiver, eliminating the thermal gradient that appears internally in steel receiver. Brogren Maria et al. [2] used aluminum polymer laminated steel reflector and tested its optical properties, durability and reflector performance in solar thermal and photovoltaic system. Before ageing, specular reflectance value was 77% and after 2000 h in damp heat, specular solar reflectance had decreased to 42%. This decrease was found to be due to degradation of the polyethylene terephthalate layer, caused by UV radiation and high temperature. Li and Wang [3] investigated the two types of solar evacuated tube to measure their heating efficiency and temperature with fluids of water and nitrogen gas. It was found that water temperature at 90-100°C gives better efficiency about 70% with both evacuated tubes. For the high

temperature application with ammonia, the efficiency of solar concentrating system with evacuated tube collector decreased to 40%. Arasu and Sornakumar [4] designed and tested the fiberglass reinforced parabolic trough for parabolic trough solar collector. It was tested under a load corresponding to force applied by a blowing wind with 34 m/s. They analyzed that the deflection at the center of the parabola was only 0.95 mm with wind drag force load of 72 kg, which is considered [4] adequate. Ansary and zeitoun [5] performed a numerical study of the heat loss by conduction and convection from the half insulated annulus between two concentric horizontal cylinder receivers. It was observed that the addition of fiber glass insulation to the half of the annulus facing away from the parabolic trough has a positive impact on reduction of convection heat losses by a maximum of about 25% compared to a conventional receiver. Yashavant et al. [6] numerically investigated the performance of parabolic trough receiver with outer vacuum shell and compared with non-evacuated shell receiver. The vacuum shell configuration performs better than the non-evacuated tube even without a selective coating and is significantly better with selective coating. Jin et al. [7] investigated the operational performance and energy conversion efficiency of developed 15kW solar chemical receiver/reactor for hydrogen production. Solar receiver/reactor was tested at 200-300°C. They found that the solar thermo-chemical process was feasible at this temperature level. Yu Zitao et al. [8] designed a U-type natural circulation heat pipe system and experimentally investigated for generating mid-temperature steam. It was observed that thermal efficiency of the system was 38.58% at a discharge pressure of 0.5 MPa during summer time.

This paper based on the thermal performance of parabolic trough collector for heating of air. The experimental setup is installed at NIT Kurukshetra, India (29° 58' N and 76° 53'E).

II. EXPERIMENTAL SETUP

In Experimental setup, parabolic trough collector having an aperture area 1.4884 m² and focal length 0.305m, is used for solar air heating. The schematic diagram and experimental setup of parabolic trough collector are shown in Figs. 1 and 2.

The system consists of following parts:

A. Reflector

Reflector is one of the vital part of the parabolic trough collector as it decides the fraction of solar irradiance to be collected by the absorber tube. A parabolic reflector reflects and concentrates all the sun rays on the absorber tube. The reflector is a parabolic shaped galvanized Aluminum sheet

Avadhesh Yadav is with National Institute of Technology, Kurukshetra, Haryana 136119 India (phone: 91-98961-03634; fax: 91-1744-238050; e-mail: avadheshyadava@gmail.com).

Manoj Kumar is with National Institute of Technology, Kurukshetra, Haryana 136119 India (phone: 91- 85290-37306; fax: 91-1744-238050; e-mail:manojkumar_nitk@yahoo.com)

Balram is with National Institute of Technology, Kurukshetra, Haryana 136119 India (phone: 91- 88024-37269; fax: 91-1744-238050; e-mail: balram1506244@gmail.com).

with a reflectivity of 86% at clean surface.

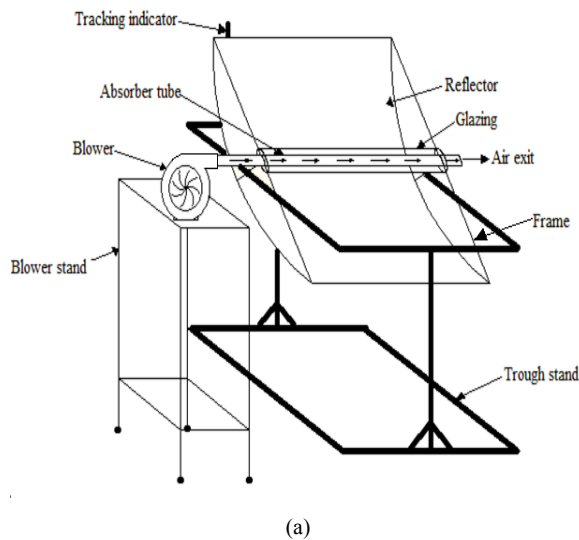

(a)

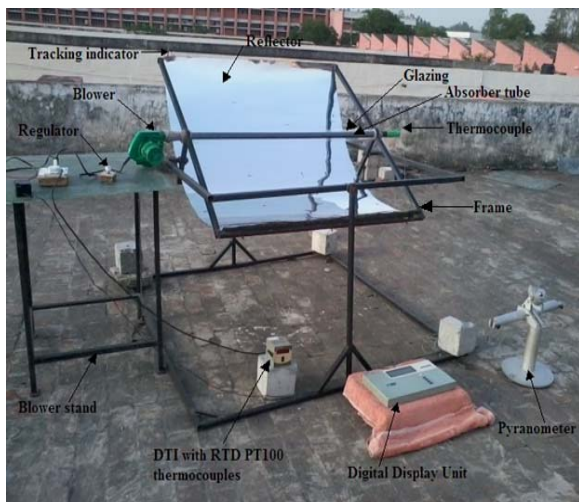

(b)

Fig. 1 (a) Schematic diagram of Experimental setup (b) Photograph of the experimental setup

B. Absorber Tube

The absorber tube is placed at the focal length of the parabolic trough collector. The outer diameter and inner diameter of absorber tube are 0.032m and 0.030m respectively along with a length of 1.22m. The solar radiations reflected by the parabolic trough collector are collected by the absorber tube. Air is used as working fluid in the absorber tube.

C. Glazing

The glazing is a concentric tubular glass cover which surrounds the absorber tube. The outer diameter and thickness of the glass tube are 0.060m and 0.002m respectively, having length equal to 1.22m.

III. MEASURING DEVICES AND INSTRUMENTS

The temperatures at different points are measured using RTD PT100 thermocouples. A digital temperature indicator is connected with the thermocouples that give the temperature with a resolution of 0.1°C. The solar radiation intensity is measured during the day using a Pyranometer (model CM11), supplied by Kipp and Zonen, Holland.

The air flow rate is measured with the help of anemometer of model AM-420. The flow rate of the air is adjusted in the beginning of experimental work. The experimental data is recorded at an interval of 30min (09:30hrs – 17:00hrs) in the month of March and April 2013.

IV. SYSTEM OPERATION

The parabolic trough collector is manually tracked on each day before the reading starts so that the solar radiations fall perpendicular to the plane of aperture area. When the solar radiations fall on the aperture area of the parabolic trough collector, these radiations are concentrated on the absorber tube. This causes the heat transfer from the surface of the absorber tube to the air flowing inside the absorber tube and air gets heated up. The copper coil increases the obstruction to the air flow due to which contact time (residence time) of air with in the absorber tube is increased and it increases the temperature of the outlet air. Two air flow rates are considered categorized as high air flow rate and low air flow rate.

V. SYSTEM OPERATION

The thermal performance of the parabolic trough collector can be estimated by the solar collector efficiency factor, η , which is defined as the ratio of the net heat gain to the solar radiation energy based on diffuse reflection area of solar collector A_p .

$$\eta = mc_{pa}(T_{out} - T_{in})/I_0 A_p$$

Aperture area of the parabolic trough collector is given by $A_p = L_p \times B_p$.

VI. EXPERIMENTAL RESULTS AND DISCUSSION

Cylindrical parabolic collector was formed in Kurukshetra and used to heat the air by manual tracking. Using this parabolic trough collector, thermal performance of various reflectors is found out. Various experiments are performed to check the thermal performance of various reflectors on parabolic trough collector. The concentrator has an aperture of a length of 1.8166m, while the absorber tube (0.030m inner and 0.032m outer diameter) has a concentric glass cover (0.04m inner and 0.043m outer diameter) around it.

Such a parabolic trough collector is used to check the thermal performance of various reflecting sheets. When the radiation falls on parabolic trough collector reflector then whole of the radiations will be collected on a line of absorber where the absorber is placed. Now the blower placed at one end of pipe blows the air with mass flow rate 0.01018 kg/s

through the heat absorbing pipe. Experiments are performed from 9:00 hours to 17:00 hours.

There are following cases of reflectors:

A. Variation of Solar Intensity and Temperatures with Time for Stainless steel Sheet as Reflector

The collector was exposed to solar radiation for half an hour before the start of reading and experimental data was recorded after regular intervals of half an hour during the day time (09:00 hours to 17:00 hours)

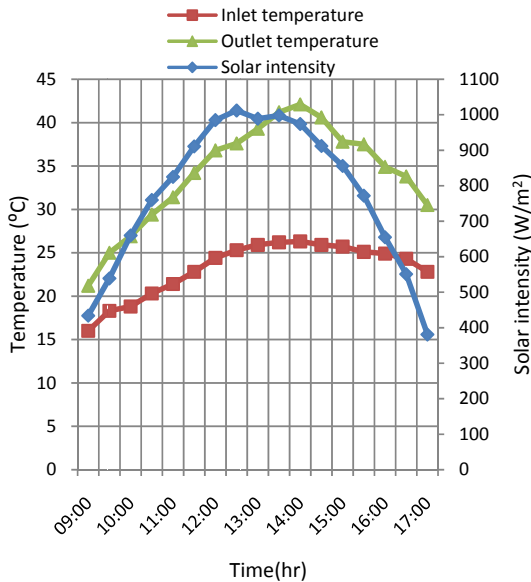

Fig. 2 Variation of outlet temperature, inlet temperature and solar intensity with time for stainless steel sheet as reflector

From the graph it is analyzed that the outlet temperature of air is minimum at 9:00 hours which increases gradually with time and reaches its maximum 42.1°C at 14:00 hours. After that temperature starts to decrease gradually. This is because solar radiation falls perpendicularly on the trough and most of radiations are collected on given length of absorber.

B. Variation of Solar Intensity and Efficiency with Time for Stainless Steel Sheet as Reflector

From 09:00 hours to 09:30 hours, efficiency increases because the variation in temperature difference is faster and intensity of radiation is very low which then decreases up to 10:30 hours. From 10:30 hours to 14:00 hours, efficiency increases because of the variation in temperature difference being faster than that in the intensity of radiations. Efficiency decreases from 14:00 hours to 16:00 hours except only at 15:30 hours, because of the decrease in variation of intensity being faster than the temperature decrease. Hence, the efficiency of collector increases. From 16:00 hours to 17:00 hours efficiency increases rapidly.

C. Variation of Solar Intensity and Temperature with Time for Aluminum Foil as Reflector

From the graph it is noted that the maximum temperature by using aluminum foil as reflector is 48.2°C, at 14:00 hours. This is because solar radiation falls perpendicularly on the trough and most of radiations are collected on given length of absorber.

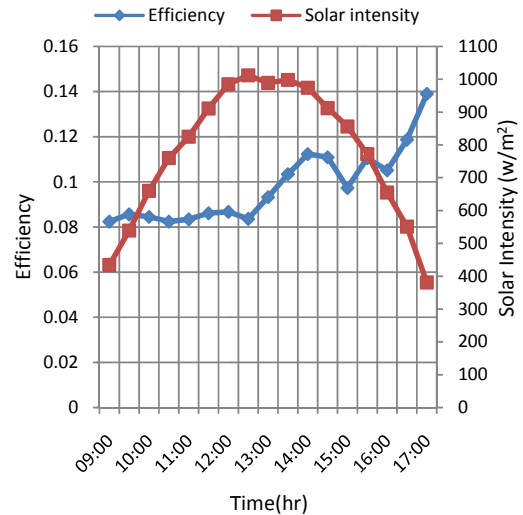

Fig. 3 Variation of efficiency of parabolic trough collector and solar intensity with time for stainless steel sheet as reflector

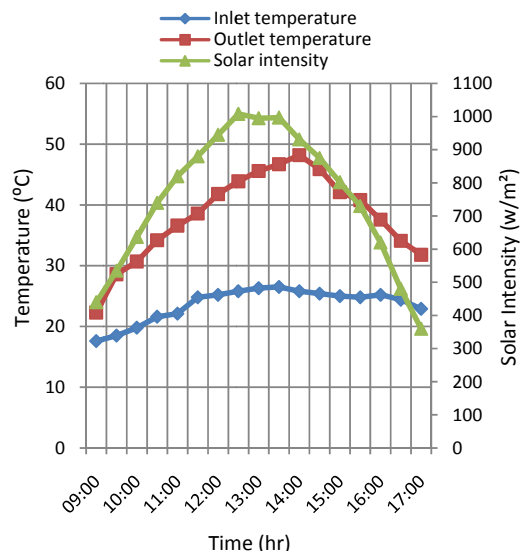

Fig. 4 Variation of outlet temperature and solar intensity with time for stainless Aluminum Foil as reflector

D. Variation of Solar Intensity and Efficiency with Time for Aluminum Foil as Reflector

From 10:30 hours to 14:00 hours, efficiency increases gradually because of the variation of temperature difference slower. From 16:00 hours to 17:00 hours efficiency increases

rapidly, this is because of the same reason of changing intensity and temperature variations.

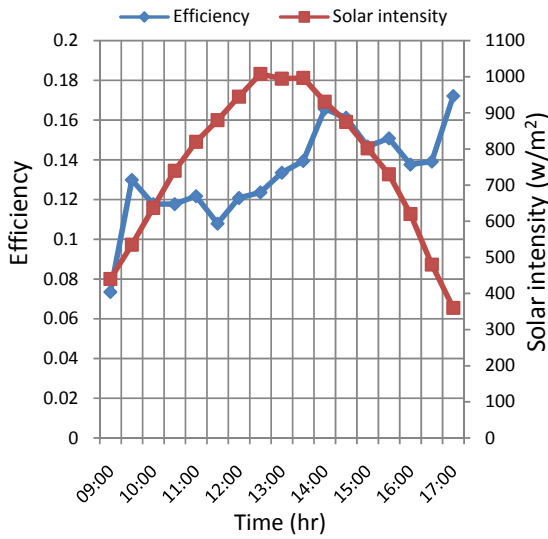

Fig. 5 Variation of efficiency of parabolic trough collector and solar intensity with time for Aluminum foil as reflector

E. Variation of Solar Intensity and Temperature with Time for Aluminum Sheet as Reflector

The maximum temperature is 52.3°C, this is because solar radiation falls perpendicularly on the trough and most of radiations are collected on given length of absorber. Again the intensity of radiation remains almost constant from 12:30 hours to 14:00 hours and due to unsteady flow of heat, temperature of pipe and temperature of air outgoing the pipe increase 4s. It is noted that outlet temperature with Aluminum sheet as reflector gives maximum temperature compare to steel and Aluminum foil.

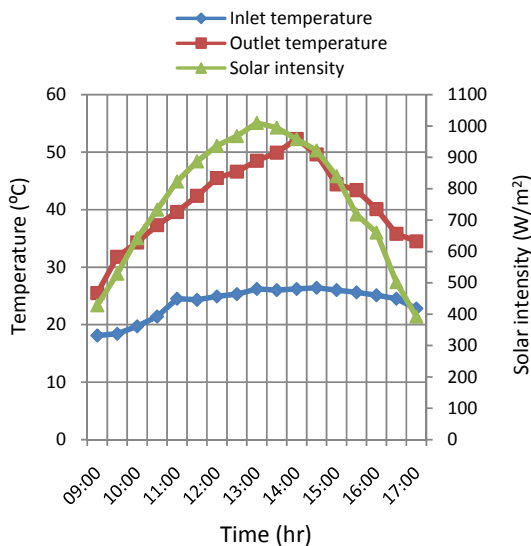

Fig. 6 Variation of outlet temperature, inlet temperature and solar intensity with time for stainless Aluminum foil as reflector

F. Variation of Solar Intensity and Efficiency with Time for Aluminum Sheet as Reflector

Initially efficiency decreases and then increases gradually.

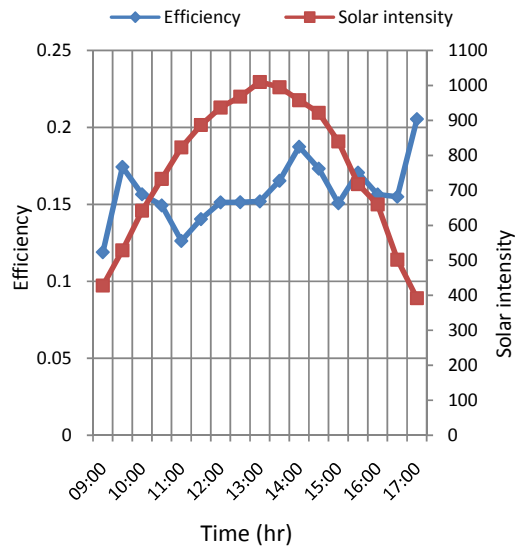

Fig. 7 Variation of efficiency of parabolic trough collector and solar intensity with time for Aluminum sheet as reflector

Efficiency decreases from 14:00 hours to 16:30 hours except only at 15:30 hours. This is because of dipping intensity, rate of which is faster than that of temperature drop. Hence the efficiency of collector increases. From 16:30 hours to 17:00 hours efficiency increases rapidly.

VII. CONCLUSIONS

In this experiment, we have found out the thermal performance of various reflectors (stainless steel sheet, Aluminum foil, Aluminum sheet) on a parabolic trough collector in one dimensional manual tracking. We conclude the following results:

We use steel sheet as reflector, the maximum temperature at the outlet of air is 42.1°C which can be used for room heating purpose. This temperature is less compared to other two reflectors.

For Aluminum foil maximum temperature is 48.2°C, which is 14.5% more than steel sheet as reflector at an air flow rate 0.01018 kg/s. Also efficiency, when using Aluminum foil as reflector compared to steel sheet as reflector is 35.48% more.

For Aluminum sheet maximum temperature is 52.3°C, which 24.22% more than steel sheet as reflector and 8.5% more than Aluminum foil as reflector. Also efficiency when using Aluminum sheet as reflector compared to steel sheet as reflector increased by 61.18%. Also efficiency by using Aluminum sheet as reflector compared to Aluminum foil as reflector is 18.98% more.

Steel sheet as reflector is very costly compared to Aluminum foil and Aluminum sheet also temperature at outlet of air is comparatively less. So it is concluded that Aluminum

sheet as reflector is economical to use as reflector with sufficient temperature of air at outlet.

NOMENCLATURE

Notation description

A_p	aperture area (m^2)
A_{sr}	shaded area of secondary reflector (m^2)
B_p	breadth of parabolic trough collector (m)
C_{pa}	specific heat (J/kg K)
D	diameter of absorber tube (m)
D_{sr}	diameter of secondary reflector (m)
I_o	solar intensity (W/m^2)
L	length of absorber tube (m)
L_p	length of parabolic trough collector (m)
L_{sr}	length of secondary reflector (m)
m	air flow rate (kg/s)
T_o	ambient temperature ($^{\circ}C$)
T_{out}	outlet temperature ($^{\circ}C$)

Greek

η	Solar collector efficiency
--------	----------------------------

REFERENCES

- [1] Flores V. and Almanza R., "Direct steam generation in parabolic trough concentrators with bimetallic receivers", *Energy*, 29, 645-651 (2004).
- [2] Brogren M., Helgesson A., Karlsson B., Nilsson J., Roos A., "Optical properties and system aspects of a new aluminum/polymer/laminated steel reflector for a solar concentrator", *Solar Energy Materials and Solar Cells*, 82, 387-412 (2004).
- [3] Li M. and Wang L.L., "Investigation of evacuated tube heated by solar trough concentrating system", *Energy Conversion and Management*, 47, 3591-3601 (2006).
- [4] Arasu A. Valan and Sornakumar T., "Design manufacturing and testing of fiber glass reinforced parabola trough for parabolic trough solar collectors", *Solar Energy*, 81, 1273-1279 (2007).
- [5] Al-Ansary H. and Zeitoun O., "Numerical study of conduction and convection heat losses from a half- insulated air-filled annulus of the receiver of a parabolic trough collector", *Solar Energy*, 85, 3036-3045 (2011).
- [6] Yashavant J., Daniel P., Das A. K., "Numerical investigation of parabolic trough receiver with outer vacuum shell", *Solar Energy*, 85, 1910-1914 (2011).
- [7] Jin H., Hong H., Liu Q., "Operational performance of the development of a 15kW parabolic trough mid-temperature solar receiver/reactor for hydrogen production", *Applied Energy*, 90, 137-141 (2012).
- [8] Yu Z., Zhang L., Wang W., Fan L., Hu Y., Ni Y., Fan J., Cen K., "An experimental investigation of a natural circulation heat pipe system applied to a parabolic trough solar collector steam generation system", *Solar Energy*, (article in press) (2012).